

# T-6778

## 5" HIGH SPEED SANDER

### 18,000 RPM



**OILING INSTRUCTIONS:**  
**OIL AFTER EACH USE WITH**  
**A FEW DROPS OF AIRTOOL**  
**OIL THROUGH THE AIR INLET.**  
**RUN FOR 1 SECOND TO**  
**COAT ALL INTERNAL PARTS.**

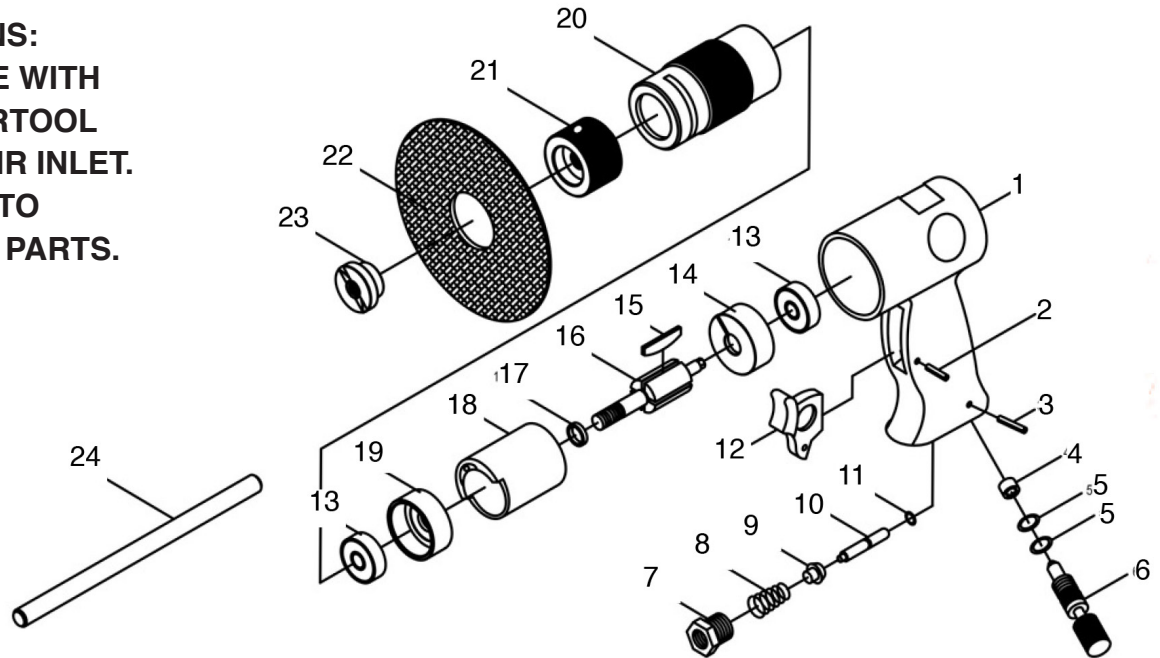

**USE 90 PSI MAXIMUM**

REF #	PART #	DESCRIPTION	QTY	REF #	PART #	DESCRIPTION	QTY
1	677801A	HANDLE COMPLETE	1	14	677814	END PLATE	1
2	677802	PIN	1	15	677815	ROTOR BLADE (SET OF 4)	1 set
3	677803	PIN	1	16	677816	ROTOR	1
4	677804	VALVE	1	17	677817	STOP RING	1
5	677805	O-RING	2	18	677818	CYLINDER	1
6	677806	REGULATOR	1	19	677819	FRONT END PLATE	1
7	677807	AIR INLET	1	20	677820	BARREL	1
8	677808	SPRING	1	21	677821	HUB	1
9	677809	THROTTLE VALVE	1	22	677822A	3" PAD	1
10	677810	VALVE STEM	1	22	677822B	4-1/2" PAD	1
11	677811	O-RING	1	22	677822C	5" PAD	1
12	677812	TRIGGER	1	23	677823	PAD NUT	1
13	677813	BEARING	2	24	677824	HOLDING ROD	1

505 N. Railroad Ave. 33435  
P.O. Box 1117 33425  
Boynton Beach, FL

SEE MORE OF OUR CATALOG AT  
[www.taylorpneumatic.com](http://www.taylorpneumatic.com)

Ph. (561)732-1111  
Fax. (561)731-4412  
Toll Free (800) 805-8665

JULY 2020 / ALL RIGHTS RESERVED / COPYRIGHT 2020