

T-6757R

1/4" HIGH SPEED DIE GRINDER

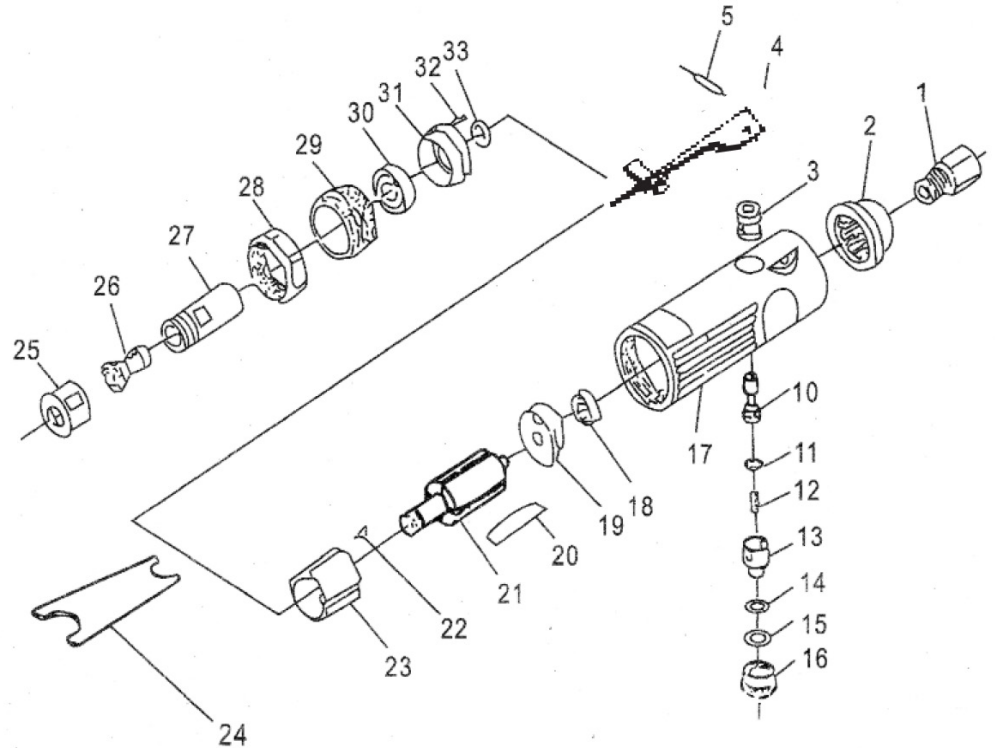

OILING INSTRUCTIONS:
OIL AFTER EACH USE WITH
A FEW DROPS OF AIRTOOL
OIL THROUGH THE AIR INLET.
RUN FOR 1 SECOND TO
COAT ALL INTERNAL PARTS.



USE 90 PSI MAXIMUM

REF #	PART #	DESCRIPTION	QTY	REF #	PART #	DESCRIPTION	QTY
1	6757R01	AIR INLET	1	20	6757R20	ROTOR BLADE (SET OF 4)	1set
2	6757R02	EXHAUST DEFLECTOR	1	21	6757R21	ROTOR	1
3	6757R03	BUSHING	1	22	6757R22	PIN	1
4	6757R04	LEVER COMPLETE	1	23	6757R23	CYLINDER	1
5	6757R05	PIN	1	24	6757R24	WRENCH	2
10	6757R10	THROTTLE VALVE	1	25	6757R25	COLLET NUT	1
11	6757R11	O-RING	1	26	6757R26	COLLET	1
12	6757R12	SPRING	1	27	6757R27	COLLET BODY	1
13	6757R13	REGULATOR	1	28	6757R28	HOUSING CAP	1
14	6757R14	O-RING	1	29	6757R29	RETAINER	1
15	6757R15	O-RING	1	30	6757R30	BEARING	1
16	6757R16	THROTTLE PLUG	1	31	6757R31	FRONT END PLATE	1
17	6757R17	HOUSING	1	32	6757R32	BALL	1
18	6757R18	BEARING	1	33	6757R33	STOP RING	1
19	6757R19	REAR END PLATE	1				