

T-6445 & T-6446

5" or 6" PALM GRIP SANDERS

(3/16" Orbit)

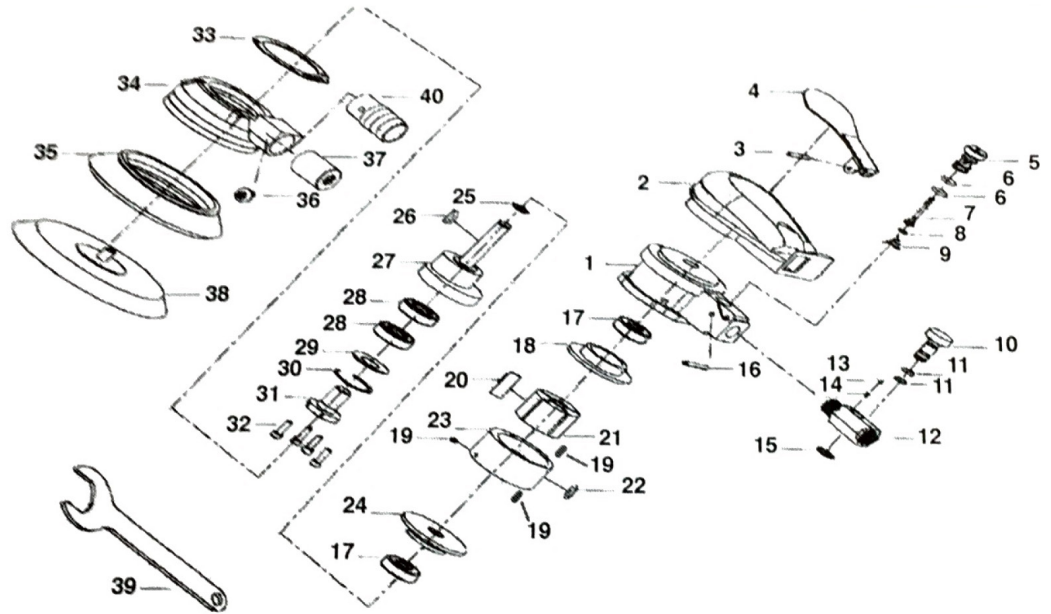

OILING INSTRUCTIONS:
OIL AFTER EACH USE WITH
A FEW DROPS OF AIRTOOL
OIL THROUGH THE AIR INLET.
RUN FOR 1 SECOND TO
COAT ALL INTERNAL PARTS.

USE 90 PSI MAXIMUM

REF #	PART #	DESCRIPTION	QTY	REF #	PART #	DESCRIPTION	QTY
1	644501	HOUSING	1	23	644523	CYLINDER	1
2	644502	HOUSING GRIP	1	24	644524	FRONT END PLATE	1
3	644503	PIN	1	25	644525	RETAINING RING	1
4	644504	LEVER	1	26	644526	KEY	1
5	644505	THROTTLE BODY	1	27	644527	COUNTERBALANCE 3/16"	1
6	644506	O-RING	2	28	644528	BEARING	2
7	644507	VALVE STEM	1	29	644529	WASHER	1
8	644508	O-RING	1	30	644530	RETAINING RING	1
9	644509	SPRING	1	31	644531	SPINDLE	1
10	644510	REGULATOR KNOB	1	32	644532	SCREW	4
11	644511	O-RING	2	33	644533	REAR GASKET	1
12	644512	AIR INLET	1	34	644534	REAR COVER	1
13	644513	BALL	1	35	644535	SHROUD	1
14	644514	SPRING	1	36	644536	SCREW	1
15	644515	RETAINING RING	1	37	644537	MUFFLER	1
16	644516	PIN	1	38	T-6415	PAD 5"	1
17	644517	BEARING	2		T-6416	PAD 6"	1
18	644518	BACK END PLATE	1	39	644539	WRENCH	1
19	644519	PIN	3	40	644540	ADAPTER	1
20	644520	ROTOR BLADES (SET OF 5)	1set			OPTIONAL ACCESSORIES	
21	644521	ROTOR	1		T-6415V	Pad 5" Velcro	
22	644522	O-RING	1		T-6416V	Pad 6" Velcro	

505 N. Railroad Ave. 33435
P.O. Box 1117 33425
Boynton Beach, FL

FOR WARRANTY INFORMATION &
WARRANTY REGISTRATION VISIT
www.taylorpneumatic.com

Ph. (561)732-1111
Fax. (561)731-4412
Toll Free (800) 805-8665