

# T-6356 MINI NEEDLE SCALER

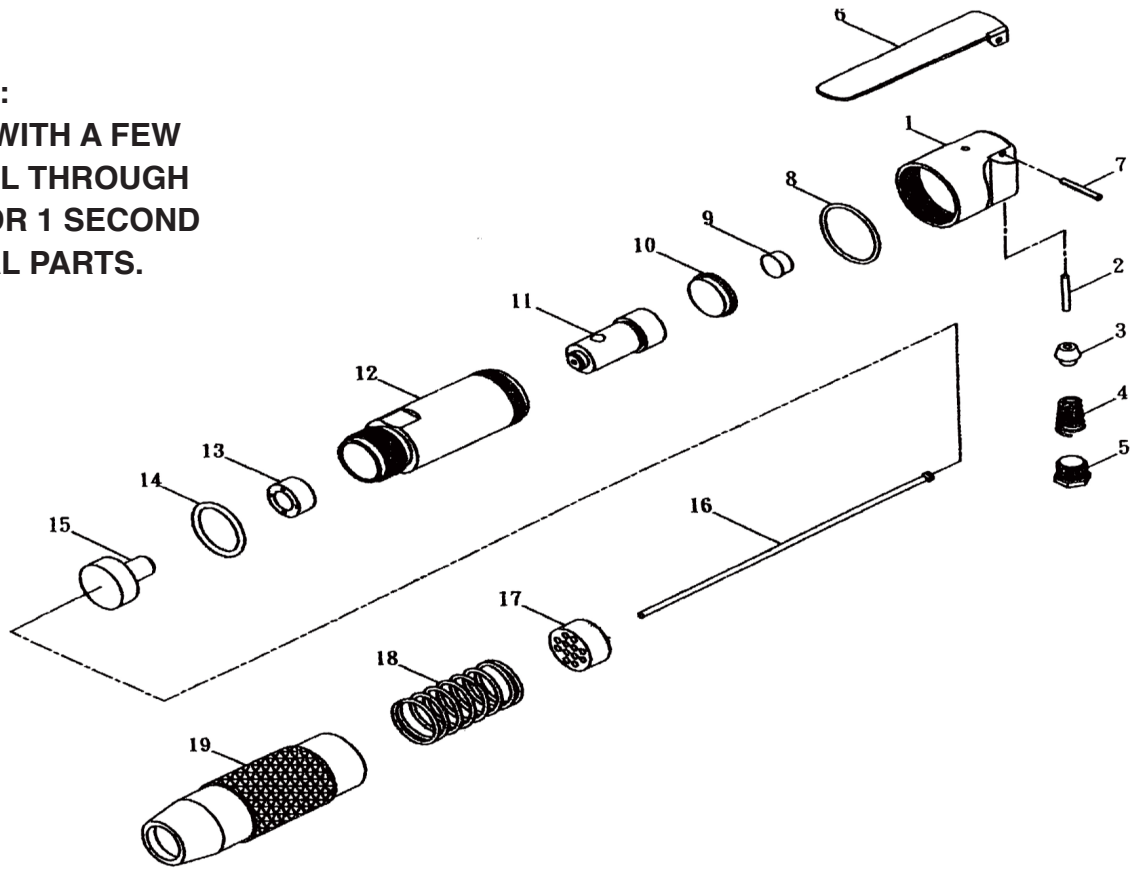

**OILING INSTRUCTIONS:**  
**OIL AFTER EACH USE WITH A FEW**  
**DROPS OF AIRTOOL OIL THROUGH**  
**THE AIR INLET. RUN FOR 1 SECOND**  
**TO COAT ALL INTERNAL PARTS.**



**USE 90 PSI MAXIMUM**

REF #	PART #	DESCRIPTION	QTY	REF #	PART #	DESCRIPTION	QTY
1	635601	BACK HEAD	1	13	635613	CHISEL BUSHING	1
2	635602	VALVE STEM	1	14	635614	O-RING	1
3	635603	VALVE SEAT	1	15	635615	NEEDLE DRIVER	1
4	635604	SPRING	1	16	T-635646	NEEDLES 3MM (12 PER SET)	1set
5	635605	THROTTLE CAP	1	17	635617	NEEDLE HOLDER	1
6	635606	LEVER	1	18	635618	SPRING	1
7	635607	SPRING PIN	1	19	635619	NEEDLE TUBE	1
8	635608	O-RING	1			<b>OPTIONAL</b>	
9	635609	RUBER CUSHION VALVE	1		T-6356RK	REPAIR KIT	
10	635610	CAP	1			INCLUDES: 2,3,4,5,13,14,15,	
11	635611	PISTON	1			16,17,18	
12	635612	CYLINDER	1				