

T-3010 Grease Gun

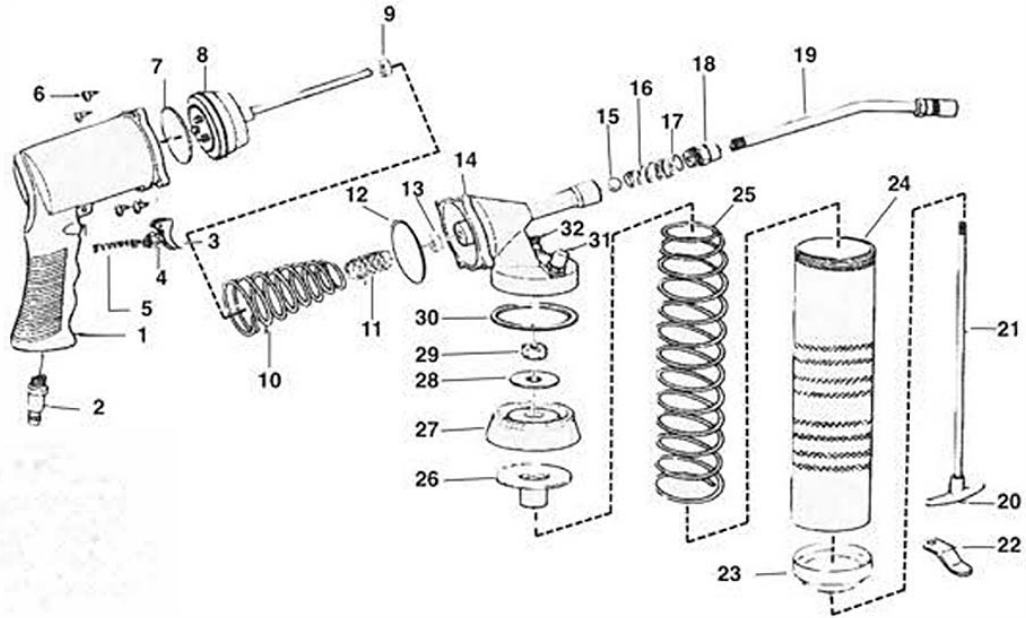

**OILING
INSTRUCTIONS: OIL
AFTER EACH USE
WITH A FEW DROPS
OF AIRTOOL OIL
THROUGH THE AIR
INLET. RUN FOR 1
SECOND TO COAT
ALL INTERNAL
PARTS.**

USE 90 PSI MAXIMUM

Ref #	Part #	Description	Qty.	Ref #	Part #	Description	Qty.
1	301001	Handle	1	18	301018	Adapter	1
2	301002	Fitting	1	19	301019	Nozzle Tube	1
3	301003	Trigger	1	20	301020	Plunger Handle	1
4	301004	Pin	1	21	301021	Plunger Rod	1
5	301005	Spring	1	22	301022	Catch Plate	1
6	301006	Screw	4	23	301023	Bottom Cap	1
7	301007	Piston Ring	1	24	301024	Tube	1
8	301008	Piston	1	25	301025	Spring	1
9	301009	Gasket	1	26	301026	Gasket	1
10	301010	Spring	1	27	301027	Plunger	1
11	301011	Spring	1	28	301028	Washer	1
12	301012	Housing Ring	1	29	301029	Nut	1
13	301013	Gasket	1	30	301030	Gasket	1
14	301014	Housing Cap	1	31	301031	Plug	1
15	301015	Ball	1	32	301032	Vent Valve	1
16	301016	Spring	1				
17	301017	Adapter Ring	1				

505 N. Railroad Ave. 33435
P.O. Box 1117 33425
Boynton Beach, Florida

FOR WARRANTY INFORMATION &
WARRANTY REGISTRATION VISIT

www.taylorpneumatic.com

Ph. (561) 732-1111
Fax (561) 731-4412
Toll Free 800-805-8665