

T-2XS T-3XS T-4XS Aircraft Riveting Hammers

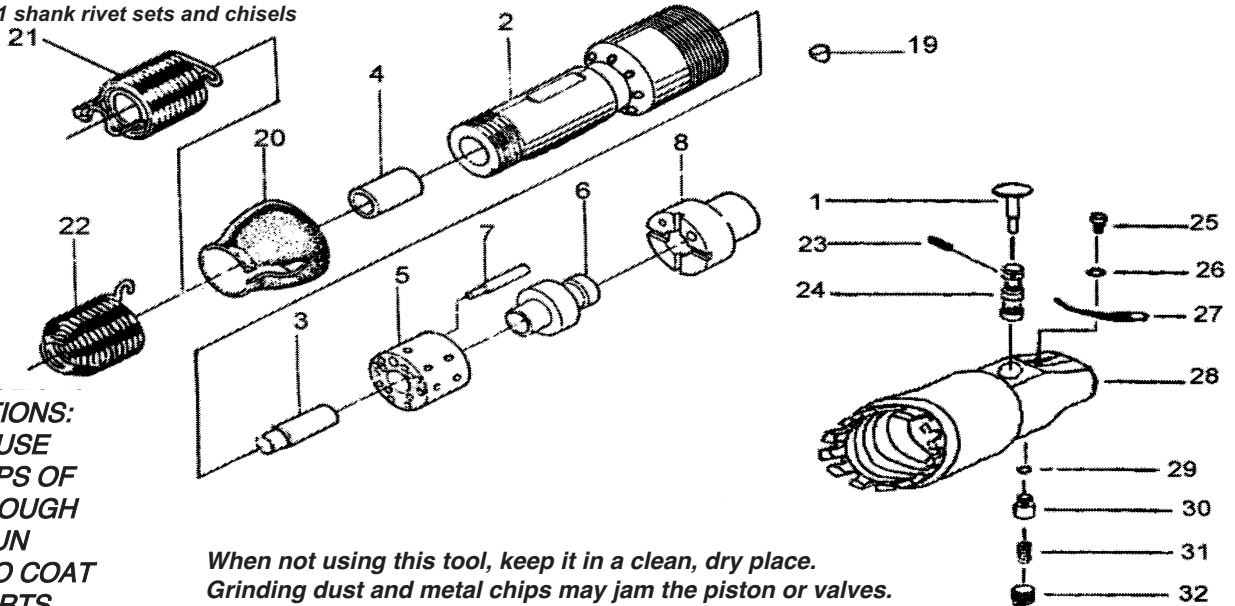

For use with .401 shank rivet sets and chisels



OILING INSTRUCTIONS:
OIL AFTER EACH USE
WITH A FEW DROPS OF
AIRTOOL OIL THROUGH
THE AIR INLET. RUN
FOR 1 SECOND TO COAT
ALL INTERNAL PARTS.

When not using this tool, keep it in a clean, dry place.
Grinding dust and metal chips may jam the piston or valves.

USE 90 PSI MAXIMUM

Ref #	Part #	Description	Qty.	Ref #	Part #	Description	Qty.
1	234XS01	Throttle Button	1	22	T-5210	Beehive Spring	1
2	2X02	2X Cylinder	1	21	T-5120	Quick Change Spring	Opt.
2	3X02	3X Cylinder	1	23	234XS23	Roll pin	1
2	4X02	4X Cylinder	1	24	234XS24	Throttle Bushing	1
3	2X03	2X Piston	1	25	234XS25	Hex Bolt	1
3	34X03	3X,4X Piston	1	26	234XS26	Spring Washer	1
4	234X04	Bushing	1	27	234XS27	Adjusting Bar	1
5	234X05	Valve Box	1	28	234XS28C	Handle Complete	1
6	234X06	Valve	1	29	234XS29	O-Ring	1
7	234X07	Pin	1	30	234XS30	Valve	1
8	234X08	Valve Seat	1	31	234XS31	Spring	1
19	234X19	Stop Pin	1	32	234XS32	Plug	1
20	234X20	Exhaust Cover	1				

505 N. Railroad Ave. (33435)
P.O. Box 1117 (33425)
Boynton Beach, Florida

FOR WARRANTY INFORMATION &
WARRANTY REGISTRATION VISIT
www.taylorpneumatic.com

Ph. (561) 732-1111
Fax (561) 731-4412
Toll Free 800-805-8665

General Air Hammer Maintenance T-7111,T-7151, T-1X, T-1XS,T-2X, T-3X, T-4X,& XS,5X,7X,9X, T-#2,#3,#4 & T-#24B, T-#34B & T-#44B



- OILING & SPECIFIC HAMMER INSTRUCTIONS:

*ALWAYS USE CLEAN DRY COMPRESSED AIR @ OR BELOW 90 PSI.

*USING DIRTY AIR CAN CAUSE THE VALVES OR PISTON TO JAM AND VOIDS THE WARRANTY.

*IF AIR IS WET, THE INSIDE OF THE TOOL CAN RUST AND VOIDS THE WARRANTY.

*USING MORE THAN 90 PSI CAN DAMAGE THE VALVES AND PISTON (THEY ARE ONLY DESIGNED TO TAKE SO MUCH PRESSURE), USING HIGH PRESSURE VOIDS THE WARRANTY.

*NEVER DRY FIRE TOOLS. THEY NEED TO BE AGAINST THE CHISEL AND WORK BEFORE THE TRIGGER IS DEPRESSED. IF THE TOOL IS DRY FIRED DAMAGE TO THE PISTON AND BARREL MAY OCCUR AND THIS WILL VOID THE WARRANTY.

*ALWAYS CHECK TO BE SURE THAT THE BARREL IS TIGHT IN THE HANDLE. LOOSE HANDLES CAN DAMAGE THE HANDLE THREADS AND VOID THE WARRANTY. OIL AFTER EACH USE WITH 1/2 TEASPOON OF AIRTOOL OIL THROUGH THE AIR INLET. RUN FOR ONE SECOND TO COAT ALL INTERNAL PARTS.

- GENERAL INSTRUCTIONS

1. ALWAYS DISCONNECT THE TOOL FROM AIR SOURCE WHEN CHANGING ACCESSORIES OR SERVICING THE TOOL.
2. USE SAFETY GLASSES, FULL FACE SHIELDS, HEARING PROTECTION AND GLOVES.
3. USE WHIP HOSE FOR QUICK DISCONNECTS.
4. VIBRATION MAY BE HARMFUL TO YOUR ARMS AND HANDS. WEAR PROTECTION.
5. INSPECT THE TOOL AND AIR SUPPLY ON A REGULAR BASIS.
6. DO NOT REMOVE GUARDS OR SAFETY DEVICES. DO NOT MODIFY OR DEFEAT SAFETY DEVICES.
7. DO NOT MAKE CONTACT WITH ELECTRICAL LINES.
8. LEAVE TRIGGER OFF BEFORE CONNECTING THE TOOL TO THE AIR SUPPLY. AVOID ACCIDENTAL STARTS.
9. WEAR THE PROPER CLOTHING. DO NOT WEAR JEWELRY, LOOSE CLOTHING, OR LONG HAIR AS IT CAN GET CAUGHT IN ROTATING PARTS. KEEP GLOVES AWAY FROM MOVING PARTS.
10. DO NOT WORK IN HAZARDOUS ATMOSPHERES WHERE SPARKS COULD IGNITE OR DETONATE FUMES.

11. WATCH WHAT YOU ARE DOING. USE COMMON SENSE WHEN OPERATING PNEUMATIC TOOLS. DO NOT USE PNEUMATIC TOOLS WHEN TIRED OR UNDER THE INFLUENCE OF MEDICATION, ALCOHOL OR DRUGS. SERIOUS PERSONAL INJURY MAY RESULT FROM A MOMENTS INATTENTION.

12. USE 90 PSI AT THE TOOL. USE 3/8", 1/2" or 3/4" HOSE OR LARGER WITH FITTINGS 9/32 MINIMUM I.D. AS SPECIFIED

13. ONLY USE CLEAN DRY COMPRESSED AIR. NEVER USE OXYGEN, CARBON DIOXIDE, COMBUSTIBLE GASES OR ANY OTHER BOTTLED GAS TO POWER THIS TOOL.

14. SECURE YOUR WORK BEFORE STARTING - USE CLAMPS OR FIND A SUITABLE WAY TO MAINTAIN STABILITY.

15. STORE TOOLS IN A CLEAN DRY ENVIRONMENT.

16. DO NOT USE DAMAGED TOOLS - MARK, AND RETURN FOR SERVICE.

17. NEVER FORCE THE TOOL, LET THE TOOL DO THE WORK.

18. STOP USE IMMEDIATELY IF TOOL IS MAKING AN UNUSUAL NOISE OR VIBRATION. HAVE TOOL CHECKED BY PROFESSIONAL TECHNICIAN.

19. WORK IN A WELL VENTILATED AREA AND USE APPROVED PERSONAL PROTECTIVE EQUIPMENT SUCH AS DUST MASKS, THAT ARE SPECIFICALLY DESIGNED TO FILTER OUT MICROSCOPIC PARTICLES. SOME DUST CREATED BY POWER SANDING, SAWING, GRINDING AND OTHER CONSTRUCTION ACTIVITIES CONTAIN CHEMICALS KNOWN TO CAUSE CANCER, BIRTH DEFECTS OR OTHER REPRODUCTIVE HARM. SOME EXAMPLES OF THESE CHEMICALS ARE: CRYSTALLINE SILICA FROM BRICKS, CEMENT AND OTHER MASONRY PRODUCTS, ARSENIC AND CHROMIUM FROM CHEMICALLY TREATED LUMBER AND LEAD FROM LEAD BASED PAINTS. YOUR RISK FROM EXPOSURE VARIES, DEPENDING ON HOW OFTEN YOU DO THIS TYPE OF WORK. TO REDUCE YOUR EXPOSURE TO THESE CHEMICALS WEAR PROTECTIVE MASKS AND CLOTHING.

20. KEEP CHILDREN, PETS AND BYSTANDERS AWAY WHILE OPERATING A PNEUMATIC TOOL. DISTRACTIONS CAN CAUSE YOU TO LOSE CONTROL. PROTECT OTHERS IN THE WORK AREA FROM DEBRIS SUCH AS METAL FILINGS AND SPARKS. PROVIDE BARRIERS OR SHIELDS AS NEEDED.

21. THESE WARNINGS AND INSTRUCTIONS CAN NOT COVER ALL POSSIBLE CONDITIONS OR SITUATIONS. THE OPERATOR MUST UNDERSTAND THAT COMMON SENSE AND CAUTIONS ARE FACTORS WHICH CAN NOT BE BUILT INTO THE PRODUCT BUT MUST BE SUPPLIED BY THE OPERATOR.

505 N Railroad Ave. (33435)
P.O. Box 1117 (33425)
Boynton Beach, Florida

SEE OUR CATALOG
at
www.taylorpneumatic.com

PH. 561-732-1111
FAX 561-731-4412
TOLL FREE 800-805-8665