

T-2005 ONE SHOT HAMMER

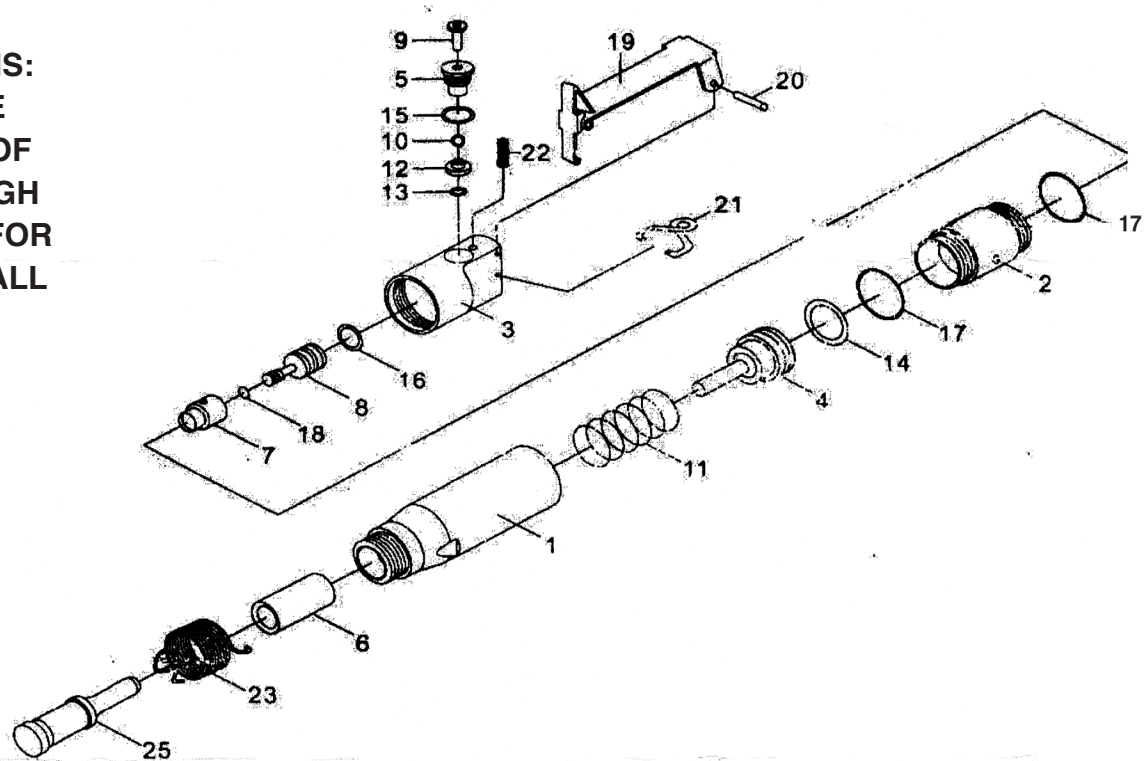

**OILING INSTRUCTIONS:
OIL AFTER EACH USE
WITH A FEW DROPS OF
AIRTOOL OIL THROUGH
THE AIR INLET. RUN FOR
1 SECOND TO COAT ALL
INTERNAL PARTS.**



USE 90 PSI MAXIMUM

REF #	PART #	DESCRIPTION	QTY	REF #	PART #	DESCRIPTION	QTY
1	200501	HEAD CYLINDER	1	13	200513	O-RING	1
2	200502	UNIT CYLINDER	1	14	200514	O-RING	1
3	200503	SWITCH BODY	1	15	200515	O-RING	1
4	200504	PISTON	1	16	200516	O-RING	1
5	200505	STOP SCREW	1	17	200517	O-RING	2
6	200506	BUSHING	1	18	200518	O-RING	1
7	200507	VALVE	1	19	200519	LEVER	1
8	200508	VALVE PISTON	1	20	200520	SPRING PIN	1
9	200509	PIN	1	21	200521	HANGER	1
10	200510	BALL	1	22	200522	SPRING	1
11	200511	SPRING	1	23	200523	RETAINING SPRING	1
12	200512	VALVE	1	25	200525	CHISEL	1

505 N. Railroad Ave. 33435
P.O. Box 1117 33425
Boynton Beach, FL

FOR WARRANTY INFORMATION &
WARRANTY REGISTRATION VISIT
www.taylorpneumatic.com

Ph. (561)732-1111
Fax. (561)731-4412
Toll Free (800) 805-8665