

T-1XS AIRCRAFT RIVETING HAMMER

.401 SPECIAL SHORT SHANK



***FOR USE WITH SPECIAL
SHORT SHANK "JIFFY"
STYLE .401 RIVET SETS
AND CHISELS**

**OILING INSTRUCTIONS:
OIL AFTER EACH USE
WITH A FEW DROPS OF
AIRTOOL OIL THROUGH
THE AIR INLET. RUN FOR
1 SECOND TO COAT ALL
INTERNAL PARTS.**

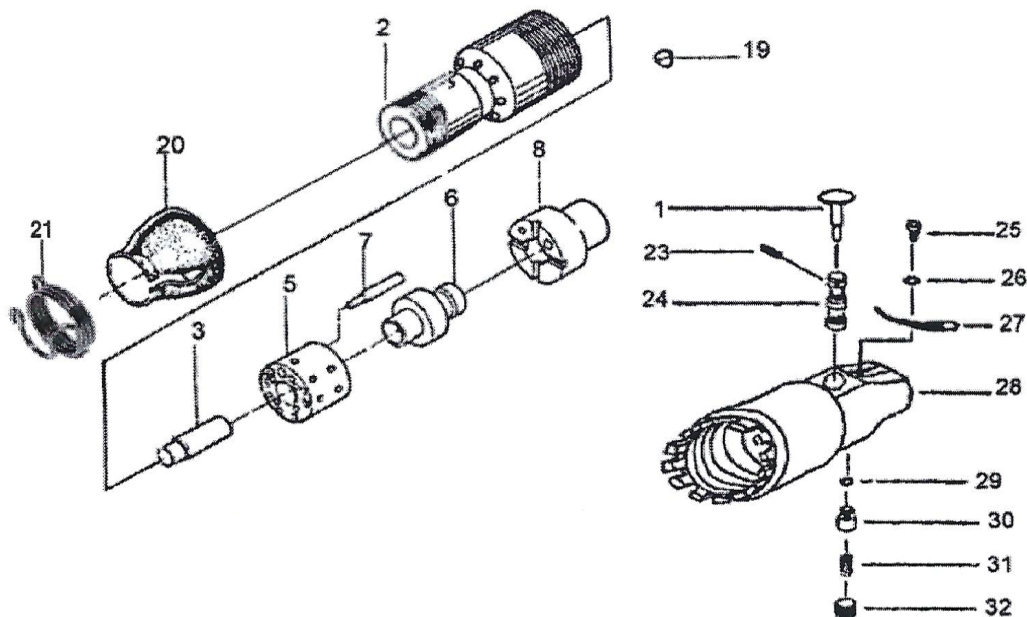

*WHEN NOT USING THIS TOOL, KEEP IT IN A CLEAN, DRY PLACE.
GRINDING DUST AND METAL SHIPS MAY JAM THE PISTON OR VALVES.*

USE 90 PSI MAXIMUM

REF #	PART #	DESCRIPTION	QTY	REF #	PART #	DESCRIPTION	QTY
1	234XS01	THROTTLE BUTTON	1	28	234XS28C	HANDLE COMPLETE	1
2	1X31	1X CYLINDER	1	29	234XS29	O-RING	1
3	1X32	1X PISTON	1	30	234XS30	VALVE	1
5	1X33	VALVE BOX	1	31	234XS31	SPRING	1
6	1X34	VALVE	1	32	234XS32	PLUG	1
7	234X07	PIN	1			OPTIONAL EXTRAS	
8	1X35	VALVE SEAT	1	T-5710		MULTI POSITION REGULATOR	
19	234X19	PIN	1	T-7922		HOSE SWIVEL	
20	234X20	EXHAUST COVER	1	T-7922R		HOSE SWIVEL W/ REGULATOR	
21	T-4120	QUICK CHANGE SPRING	1	T-8004		AIRTOOL OIL - 4OZ.	
23	234XS23	ROLL PIN	1	T-8032		AIRTOOL OIL - 1QT.	
24	234XS24	THROTTLE BUSHING	1	T-8128		AIRTOOL OIL - 1GAL.	
25	234XS25	HEX BOLT	1				
26	234XS26	SPRING WASHER	1				
27	234XS27	ADJUSTING BAR	1				

505 N. Railroad Ave. 33435
P.O. Box 1117 33425
Boynton Beach, FL

FOR WARRANTY INFORMATION &
WARRANTY REGISTRATION VISIT
www.taylorpneumatic.com

Ph. (561)732-1111
Fax. (561)731-4412
Toll Free (800) 805-8665