

## CUSTOMER DATA SHEET - BATHS

SALES CODE: BAS763

DESCRIPTION 1580 BOAT BATH WITH ALUMINIUM PLINTH

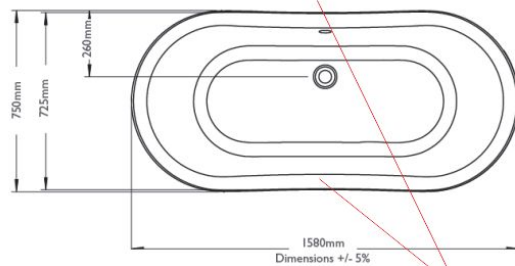
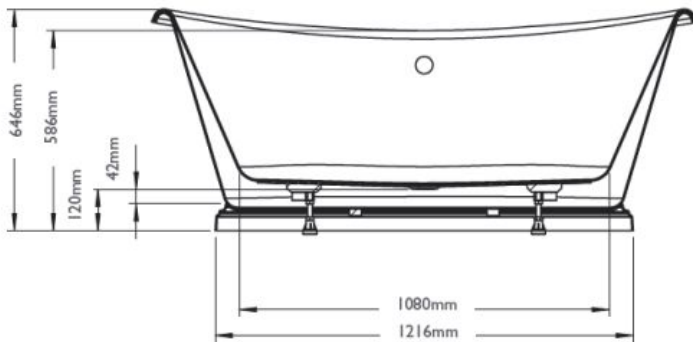

**IMPORTANT:** As the original Boat or Bateau baths were made, the rim on the long sides bend inwards by approx. 20mm in the middle, so there will be a gap between the centre of the bath and the wall

### PRODUCT DIMENSIONS

Length (mm)	Width (mm)	Depth (mm)	Nett Wgt Kg
1580	750	646	40

### PACKAGING DIMENSIONS

Length (mm)	Width (mm)	Depth (mm)	Gross Wgt Kg
xxxxx	xxxx	xxxx	xxxx

### PACKAGING DATA

Box Colour	Brown Cardboard Sleeve		
Box Qty	1	Label Colour	White Label
Label Size	100 X 50	Label Qty	2

### OUTER BOX DIMENSIONS (If Applicable)

Length (mm)	Width (mm)	Height (mm)	Gross Wgt Kg
Barcode			

### PRODUCT DETAILS

Country of Origin	China & India	Certification	FSC	CE
Fitting Instruction	No	Material Colour Ref	European White	
Product Material	Acrylic	Material Thickness	xxxxxx	
Volume (Ltr)	180	Displaced Capacity	xxx	
Leg Set Inc'	Legset Included	Waste Inc'	Waste Not Included	
Drilled/Undrilled	Undrilled For Taps	Includes Grips	No Grips Supplied	
Embossed	No	No of Tapholes	None	
Anti-Slip	No			