

***Accurate***

807 E. Parkridge Ave. • Corona, CA 92879  
1-888-ACCU-372 • 951-479-0909 • Fax: 951-479-0305  
[www.accuratefishing.com](http://www.accuratefishing.com)



# BOSS MAGNUM TWINDRAG REEL

USAGE MANUAL



***Accurate***

## | CONTENTS

Features	1
Getting Acquainted	2
Operation	3
AccuCast™ System	4
Drag Variance	5
Filling the Spool	5
Rod Mounting	5
Line Capacities	6
Maintenance	7
Warranty	8

***Accurate***

# GETTING ACQUAINTED

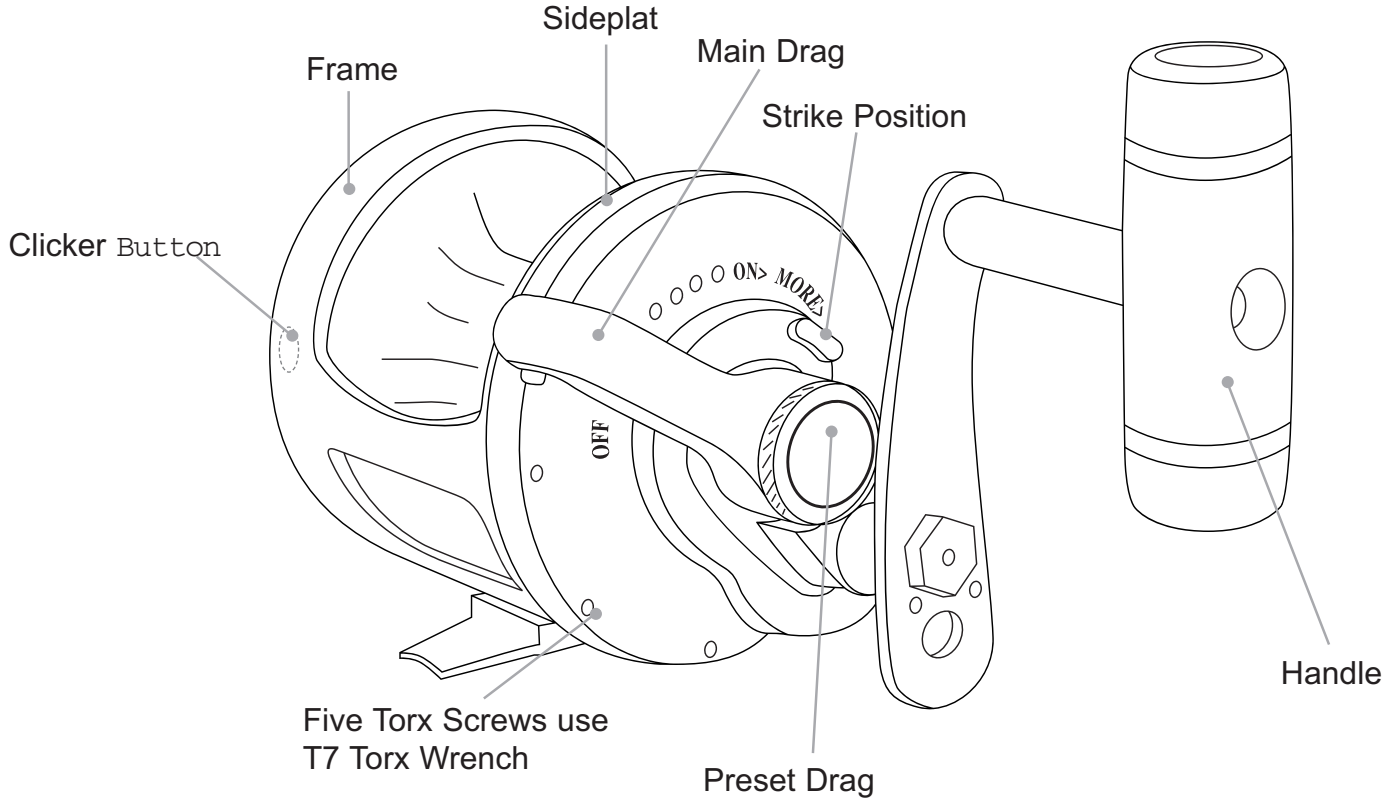

## MAINTENANCE

Bearing Maintenance - The Class 5 A.B.E.C. bearings in the Boss Magnum are teflon impregnated in the ball bearing race; thus, no lubrication is needed for these bearings.

NOTE: Do not lubricate the two small weep holes on the bottom of the reel. These holes are for water to drain out of the reel.

Wash down your Boss Magnum with fresh water after each use. We recommend lightly spraying it to prevent water from being forced inside. If heavy pressure is needed put the reel in the "Full" drag position. Do not completely submerge the reel into water. Wipe the exterior parts with an anti-corrosion lubricant. We recommend Corrosion X® by Corrosion Technologies. Use a good quality reel oil to lubricate all the parts indicated with the oil symbol.

Periodically, check all exterior screws to make sure they are tight. Screws may loosen over time with boat vibrations.

We recommend yearly maintenance of your Boss Magnum reel with a service professional. Preventative maintenance of your Boss Magnum reel will keep the internal parts in proper working condition and prolong the life of the reel.

Storage - When storing your Boss Magnum reel, put the reel in "Free Spool" and the clicker in the on position.

---

For further details on maintaining your Accurate Boss Reel, please visit Tech Support at our web site: [www.accuratefishing.com/suport/boss.php](http://www.accuratefishing.com/suport/boss.php)

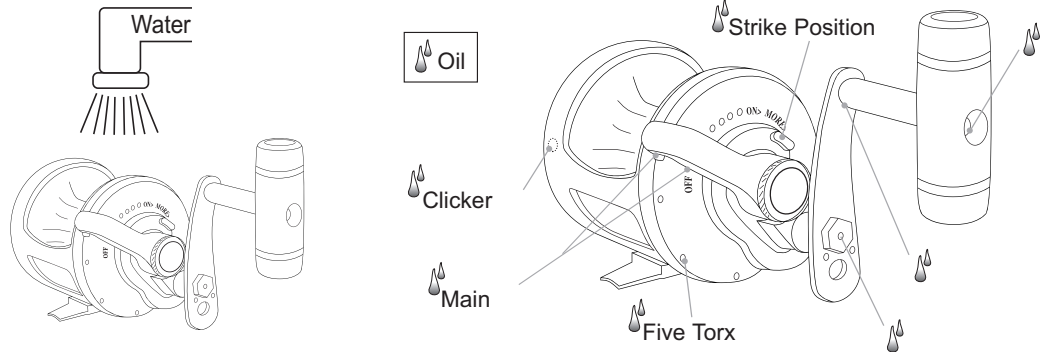

# ACCURATE FISHING PRODUCTS ONE YEAR LIMITED

**How Long Does The Limited Warranty Coverage Last?** This limited warranty runs for a period of one (1) year starting from the date that the Boss reel was first purchased by the consumer. Coverage terminates if you sell or otherwise transfer the reel.

**What Does The Limited Warranty Cover?** Accurate Fishing Products warrants to the original purchaser that its Boss Tech fishing reels are free from defects in material and workmanship with the exceptions stated below.

**What Is Not Covered By This Limited Warranty?** This limited warranty does not cover damage or problems caused by misuse, abuse, neglect, accident, installation, alterations or failure to properly maintain the reel.

**What Will Accurate Fishing Products Do?** Accurate Fishing Products will repair or replace any reel which is defective in material or workmanship covered by this limited warranty at no charge.

**How Do You Get Service?** If something goes wrong with your reel, send it to Accurate Fishing Products, postage pre-paid, along with a sales receipt or other proof of the date of purchase. Be sure to include a short note explaining the problem. Send the reel to Accurate Fishing Products at:

**Accurate Fishing Products Warranty Repairs 807 E. Parkridge Avenue Corona, California 92879 1-888-ACCU-372**

Please pack your reel with all parts that have been removed securely in a sturdy box. Be certain that your package is adequately insured and mailed with a shipping company that has tracking capabilities. Be sure to include your name, address and telephone number. Accurate Fishing Products will inspect your reel and contact you within 30 days of receipt to inform you whether the problem is covered by this limited warranty. There is no charge for the inspection.

**What Are The Warranty Limitations And Limitations of Liability?** There are no other express warranties. Any warranty of merchantability or fitness for a particular purpose is limited to the duration of this limited warranty. Accurate Fishing Products shall NOT be liable for any loss of use, loss of time, inconvenience, commercial loss, or other incidental or consequential damages. Some states do not allow limitations on how long an implied warranty lasts, or the exclusion or limitation of incidental or consequential damages, so the above limitations and exclusions may not apply to you. This limited warranty gives you specific legal rights, you may have additional rights which vary from state to state.

## FEATURES |

- >Patented TwinDrag™ system
- >Billet 6061 - T6 aluminum
- >7 Class-5 ABEC stainless steel bearings
- >Titanium drag friction washers
- >Unhindered free-spool at every drag setting
- >Dry AccuDrags
- >Stainless-steel gears, springs, harness lug, head screws
- >Oversized handle
- >1 Year warranty
- >AccuCare reel service
- >Proudly designed and manufactured in the USA
- >Left-handed models available

## THE TWINDRAG™ SYSTEM



Traditional fishing reel design applies the drag pressure to only one side of the spool — resulting in uneven pressure placed on reel components and excessive heat buildup. The TwinDrag™ system applies equal pressure to both sides of the spool which distributes the drag friction over the surface of two drag plates instead of one. That's 50% of the total drag pressure on each side, resulting in a smoother drag with less heat build-up and a balanced load on reel bearings and spool. TwinDrag reels also have extremely accurate drag settings with very little fluctuation. In fact, Boss Magnum reels will fluctuate less than 1-pound in total drag when line is drawn at any speed. For example: when the drag is set to 20 pounds on a Boss Magnum reel, drag pressure will only vary between 19.5 and 20.5 pounds, or less!



## BOSS MAGNUM AccuCast™™

Available on some models

To combat backlashes while maximizing casting distance, Accurate introduces AccuCast™, a precision engineered cast-control system. Virtually foolproof, AccuCast™ allows anglers to adjust cast-control tension so that “thumbing” the spool is no longer necessary to prevent backlashes. As a bonus, when discovering this new-found confidence, anglers will be encouraged to apply more energy to each cast to maximize distance.

The AccuCast™ cast-control design doesn't rely on the influence of centrifugal weights inside the reel, but rather works by the reel's drag washers slightly “grazing” the sides of the spool. This grazing effect is so precisely controlled by an easy to adjust cast-control knob that the control influence can be increased for lessskilled casters, set very lightly for the angler who needs just a little spool slowdown when casting, or for the pro, backed off completely when thumb pressure alone can get the job done.

When lure fishing, for example, a good starting point is to hold the rod horizontally, put the reel in freespool and turn the AccuCast™ control knob just enough so the lure begins to drop slowly as it pulls line from the tip of the rod. Then, gradually increase knob tension (clockwise) just enough to stop the lure from falling. For most anglers most of the time, that's the perfect setting for optimum performance.

**AccuCast™ KNOB**  
Turn the knob clockwise  
for more control or  
counter-clockwise for less.

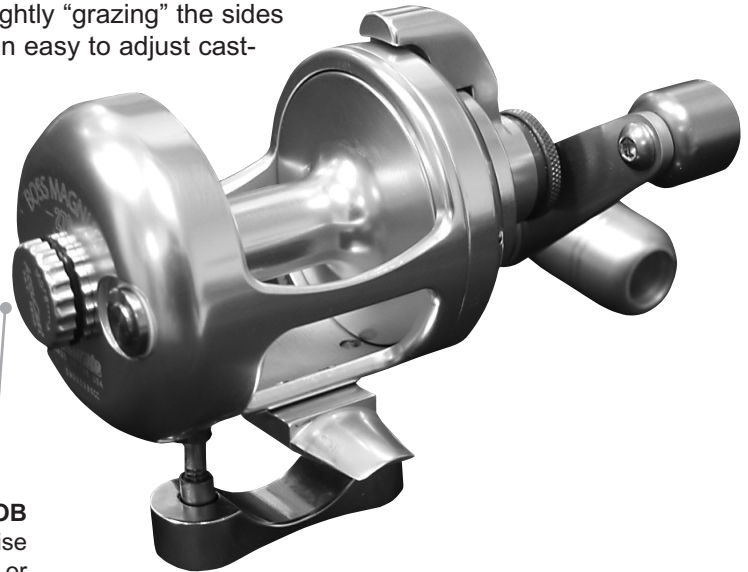

## DRAG VARIANCE

Thanks to the Boss Magnum's exclusive TwinDrag technology, the drag tension you set will vary no more than one pound when line is pulled off the reel at any speed! Unfortunately, there is another factor which causes drag variance that needs to be accounted for. This factor is based on how full the reel is with line. When the spool is filled, the line is being pulled off a high point on the spool. As the amount of line on the spool reduces, the line is pulled from a lower area on the spool. There is less leverage used when the line is pulled at a lower level, which means the line needs more force to move the spool against the drag. The drag setting has not been decreased, but the line will encounter increased tension. Account for the drag pressure to approximately double when 25% of the line has been removed from a full spool.

## FILLING THE SPOOL

Begin filling the Boss Magnum reel by attaching the line securely to the reel spool. With tension applied to the line, fill the spool to approximately 1/4" from the spool edge.

NOTE: Filling the spool too close to the spool edge means you will have to level wind perfectly to prevent a high spot from occurring. If a high spot occurs, the reel will not allow you to retrieve all of the line. Leave room on the spool to level wind comfortably while fighting a fish.

Because of mono compaction when using ultra light line, we recommend first filling the spool with at least 2/3 spectra line.

Mono Compaction - Mono compaction is a problem that happens with light line. The smaller the mono line diameter, the more elasticity the line will have. The elasticity is multiplied by the amount of line put on the spool which creates pressure on the spool. When too much light line is added, the pressure can expand the spool. This could cause the reel to perform with inconsistent drag pressure or, if enough pressure is built up, break the spool in half. Always put the least amount of ultra-light line on the reel as needed.

## ROD MOUNTING

Mount the reel on the rod with its rod clamp. If your reel is a right-handed model, be sure to mount the reel with the handle on the right.

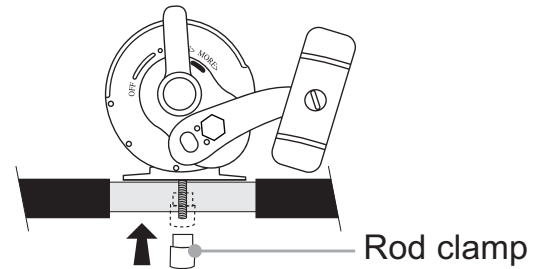

## | LINE CAPACITIES

MODEL	WEIGHT	GEAR RATIOS	LINE CAPACITY	SPECTRA LINE CAPACITY
			lbs./line dia. inches/yds.	lbs./yds · mono top shot
B-197C	18 oz.	4.6 : 1	15 /.015 / 300	50 / 200 · 30 / 50
B-197C	18 oz.	6 : 1	15 /.015 / 300	50 / 200 · 30 / 50
B-270C	20 oz.	4.6 : 1	20 /.018 / 300	50 / 300 · 30 / 100
B-270XC	20 oz.	6 : 1	20 /.018 / 300	50 / 300 · 30 / 100
B-870NC	20 oz.	4.6 : 1	30 /.022 / 250	50 / 400 · 30 / 50
B-870XNC	20 oz.	6 : 1	30 /.022 / 250	50 / 400 · 30 / 50
B-870C	22 oz.	4.6 : 1	30 /.022 / 300	50 / 400 · 30 / 100
B-870XC	22 oz.	6 : 1	30 /.022 / 300	50 / 400 · 30 / 100
B-665NC	24 oz.	4 : 1	30 /.022 / 350	65 / 275 · 50 / 75
B-665XNC	24 oz.	6 : 1	30 /.022 / 350	65 / 275 · 50 / 75
B-665HC	26 oz.	4 : 1	40 /.024 / 300	65 / 400 · 50 / 75
B-665HXC	26 oz.	6 : 1	40 /.024 / 300	65 / 400 · 50 / 75

## OPERATION

Basic operation of your Boss Magnum fishing reel is no different from operating any other fishing reel except for setting the lever drag. The most popular drag setting is to set your drag so when the Main Drag Lever is in the strike position it is at approximately 30% of your line strength. To obtain this setting, start by adjusting the Main Drag Lever so it is in the Free Spool position. NOTE: The Preset Lever cannot be adjusted unless the Main Lever is in the free spool position. Then adjust the Preset Drag Lever by moving it clockwise or counter clockwise. Move your Main Drag Lever to the strike position. If the drag is too light or heavy, repeat the process until you've reached your desired drag pressure.

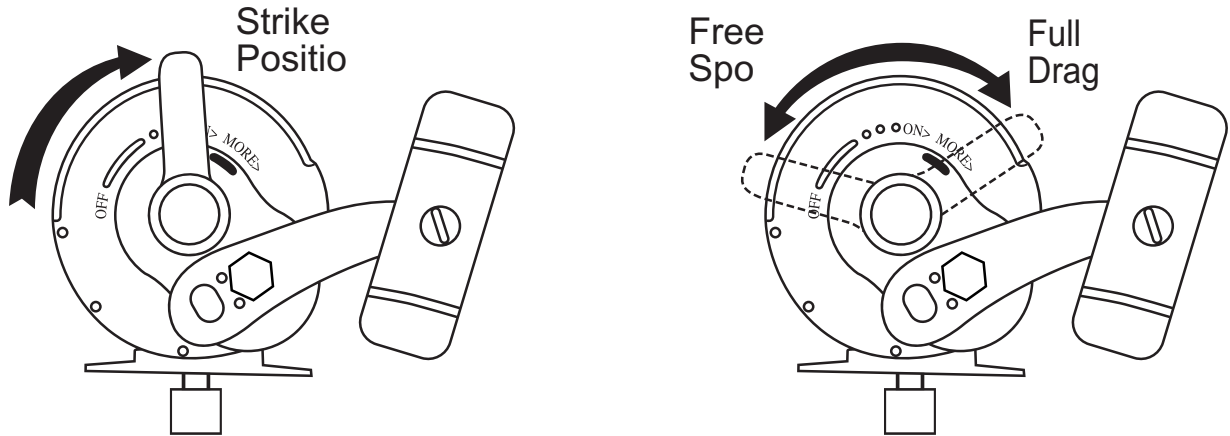

NOTE: Because the Boss Magnum reels are equipped with TwinDrag Technology, the drag pressure you can apply is unlimited. Feel free to crank up the drag pressure to your desired setting.