

*NB: HINGED PANELS HAVE H/DUTY STAYS (PSV/10/899) AND 2 SOUTHCO SEALED LEVER LATCHES
 BLACK SIKA 260 (ADA-00027) IS USED ON PANELS WHICH HAVE STRENGTHENERS
 BETASEAL (ADA-00006) IS USED TO SEAL THE RADIATOR PANEL
 IF A PANEL IS REMOVED, BE SURE TO USE NEW M8x20 BOLTS (PSV/43/348) ON RE-ASSEMBLY
 IF REPLACING RADIATOR MESH, BE SURE TO USE GENUINE WRIGHTS PARTS FOR CORRECT AIR FLOW

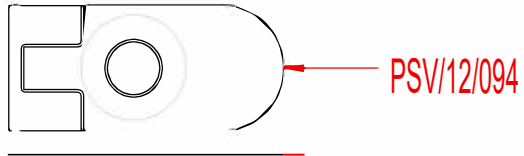

PSV/13/916
BALLY RUBBER
BOUGHT PER METRE



Index	Part No.	Description	Qty
1	PSV/133/102	PILLAR PACKER	8
2	PSV/135/032	N/S SIDE PANEL	1
3	PSV/36/466	BODY SIDE PANEL	1
4	PSV/36/468	BODY SIDE PANEL	1
5	PSV/36/469	BODY SIDE PANEL	1
6	PSV/36/470	BODY SIDE PANEL	1
7	PSV/36/471	BODY SIDE PANEL	1
8	PSV/71/823	BODY SIDE PANEL	1
9	PSV/36/473	BODY SIDE PANEL	1
10	PSV/36/474	BODY SIDE PANEL	1
11	PSV/36/475	BODY SIDE PANEL	1
12	PSV/36/477	Battery Panel Assembly	1
13	PSV/36/478	BODY PANEL CAPPING	1
14	PSV/36/481	BODY SIDE PANEL	1
15	PSV/36/508	SB200 RADIATOR PANEL	1
16	PSV/36/509	BODY SIDE PANEL	1
17	PSV/99/090	BODY SIDE PANEL	1
18	PSV/36/510	BODY SIDE PANEL	1
19	PSV/36/555	BODY SIDE PANEL	1
20	PSV/54/095	HINGE PANEL STRIKER PLATE	4
21	PSV/11/142	SIDE PANEL SUPPORT BRKT	7
22	PSV/11/155	SIDE PANEL BKT	2
23	PSV/11/483	SHEETMETAL ATTACHMENT BRKT	2
24	PSV/99/108	SIDE PANEL ATTACHMENT BRKT	8
25	PSV/11/696	SIDE PANEL ATT BRACKET	12
26	PSV/99/106	SIDE PANEL ATT BRACKET	1
27	PSV/40/778	SIDE PANEL ATT BRACKET	4

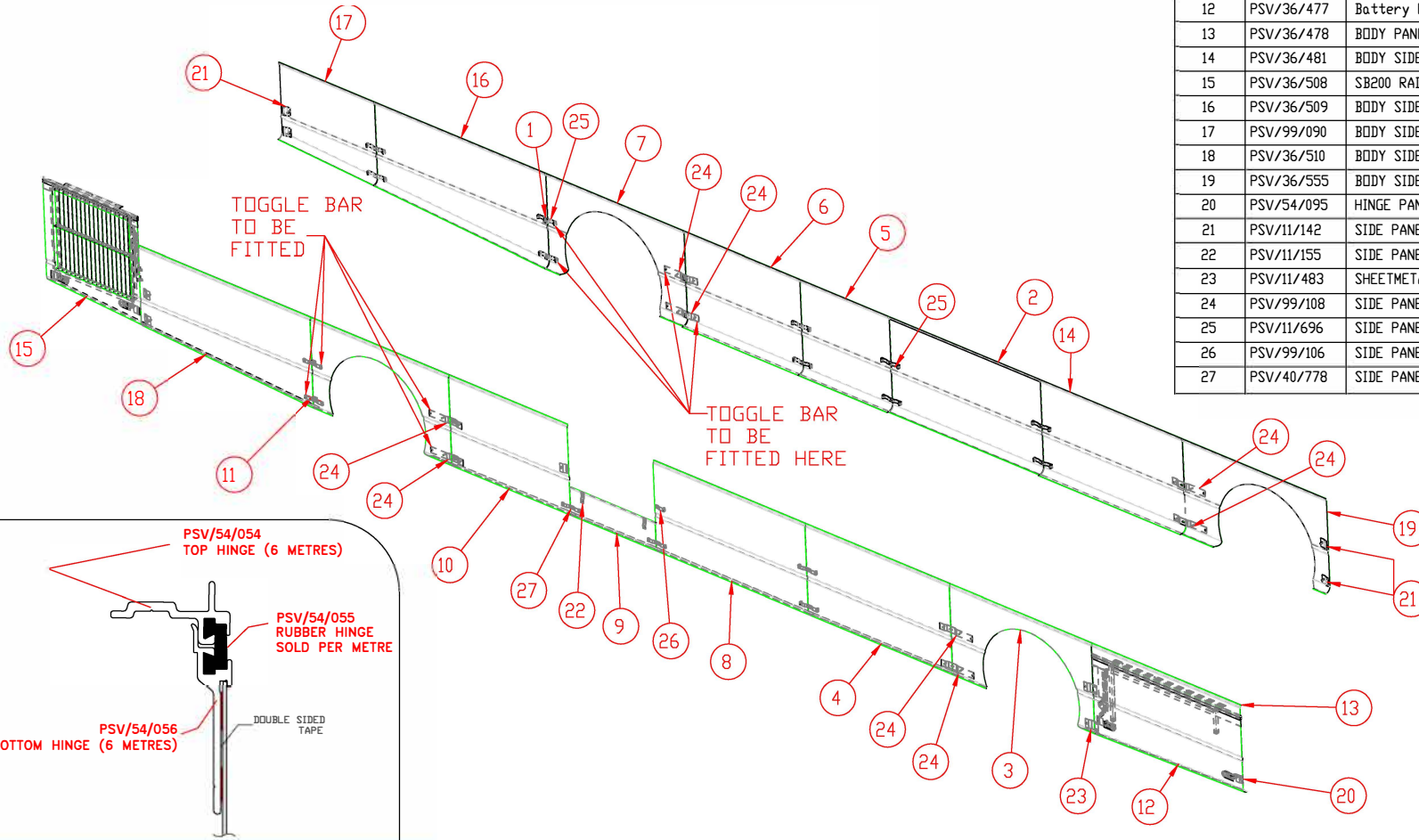

W12-00326 - SHK-00319
 SHEETMETAL - BASIC ASSEMBLY

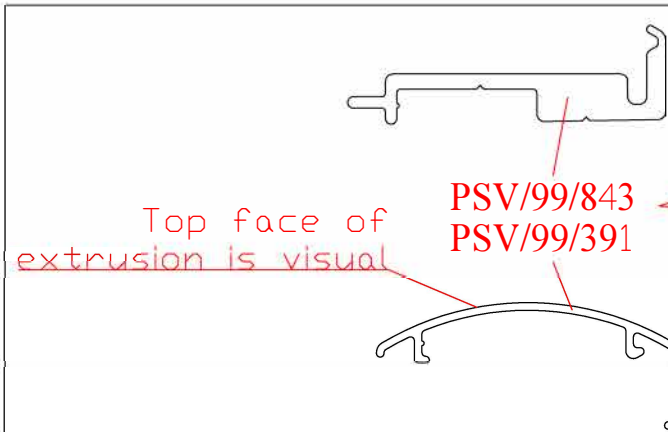
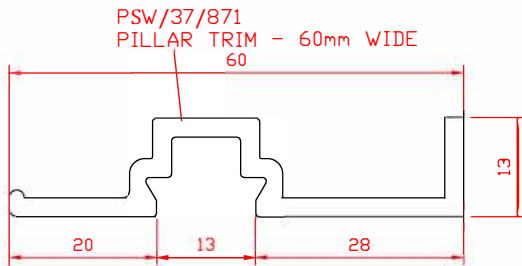
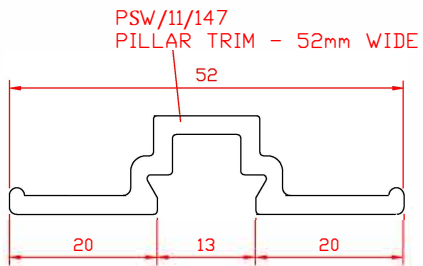
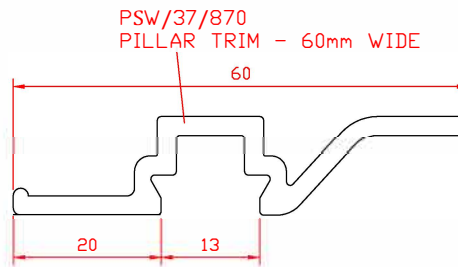
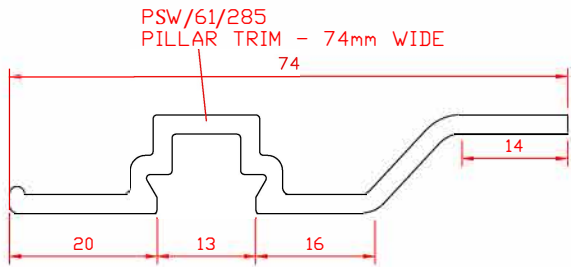
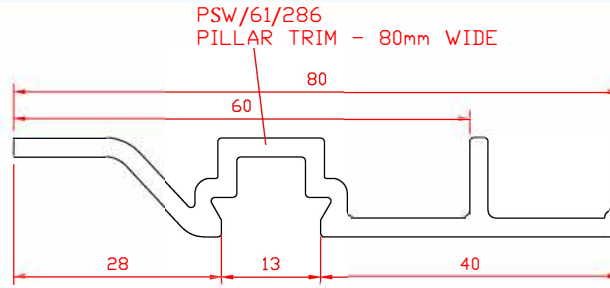
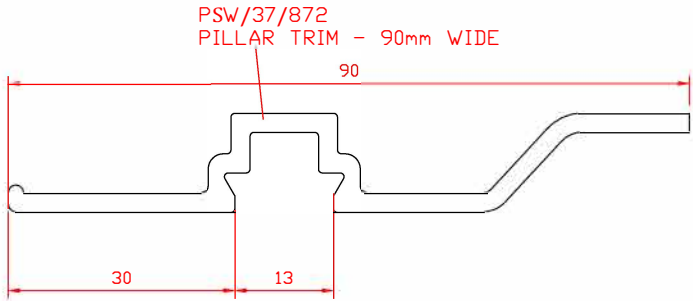

Top face of
extrusion is visual

These run the whole
length of the bus.

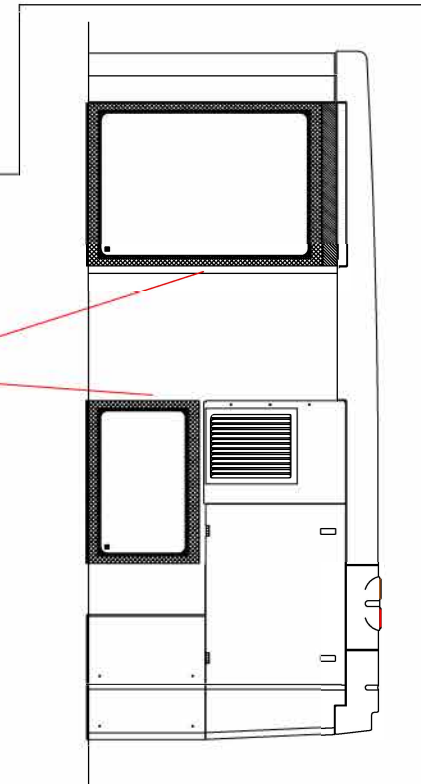

ALLOY
PILLAR TRIMS