

COMPLETE RAMP SYSTEMS

Section 1

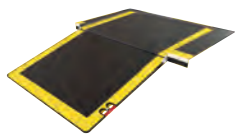

OE MANUAL RAMPS

1.1

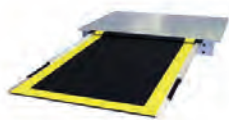

OE POWERED RAMPS

1.5

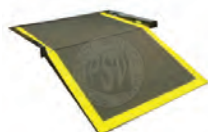

AFTERMARKET RAMPS

1.11

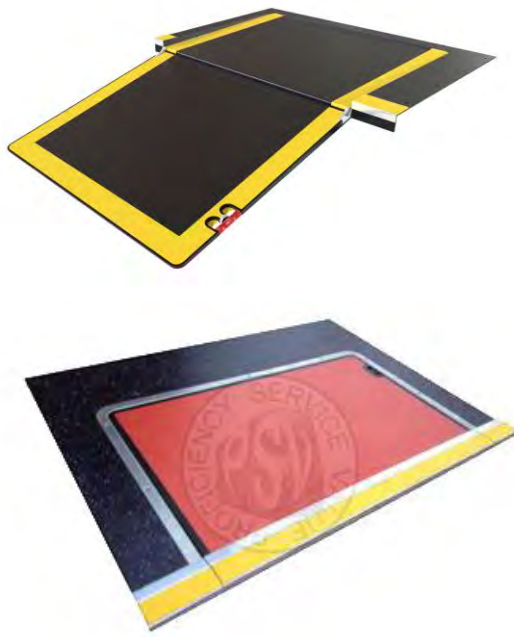

PSV UK and EU Compliant Manual Ramp

PSV UK and EU Compliant Manual Ramp Narrow

The PSV UK and EU Compliant Manual Ramp was designed to combat the increasing need for a lightweight robust manual ramp from Bus Body Builders and Bus Operators. Although the top board is a composite material its design is such that it avoids splintering commonly seen on existing market alternatives.

The ramp incorporates the same reinforced bungee style handle that has seen PSV ramps become a popular choice with Operators in the Aftermarket. The later ramp has a narrower top board (approximately 90mm slimmer) and is more suitable for vehicles with a smaller front door aperture. The ramp can also be used to replace Compak CP9 ramps on later vehicles.

Key Features

- Conforms to current UK and EU Regulations
- Cassette style design
- Integral floor
- Easy Retro-fit
- Safe working load 300Kg
- Fully retractable bungee style handle
- Light-weight construction
- Concealed maintenance free pivots
- Posture friendly deployment
- Can be manufactured in a range of sizes to suit step height

Key Benefits

- Lighter than existing market alternatives
- Strong, robust, metal frame
- Avoids splintering associated with other composite boards
- Impact damage resistant

Safety Features

- Safety interlock
- High visibility edges
- Anti-slip surface

The ramp is currently supplied to leading UK Body Builder including Alexander Dennis, Optare and Wrightbus. Please specify the PSV ramp when ordering.

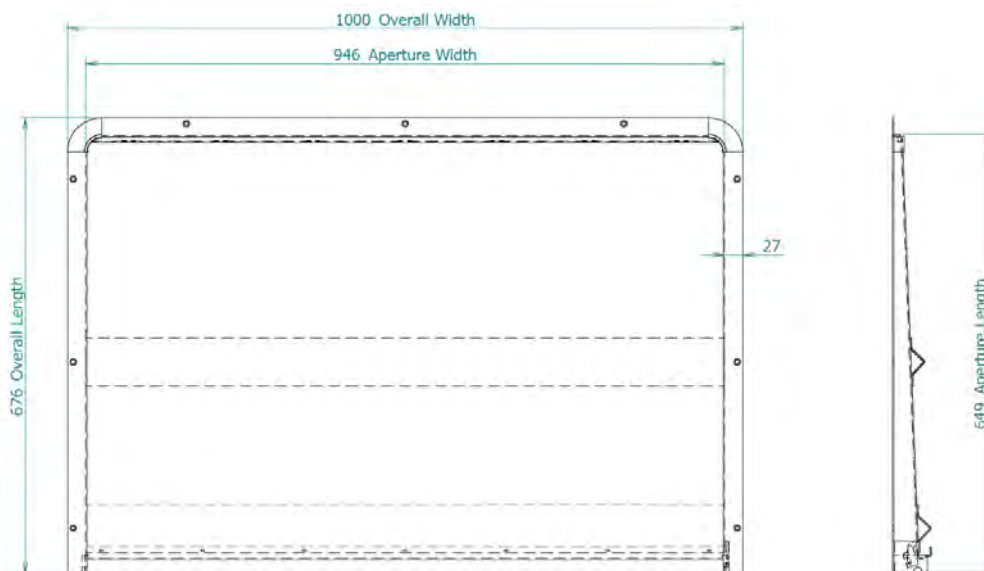

*PSV UK and EU Compliant Manual Ramp Standard

OE MANUAL RAMPS

1.1

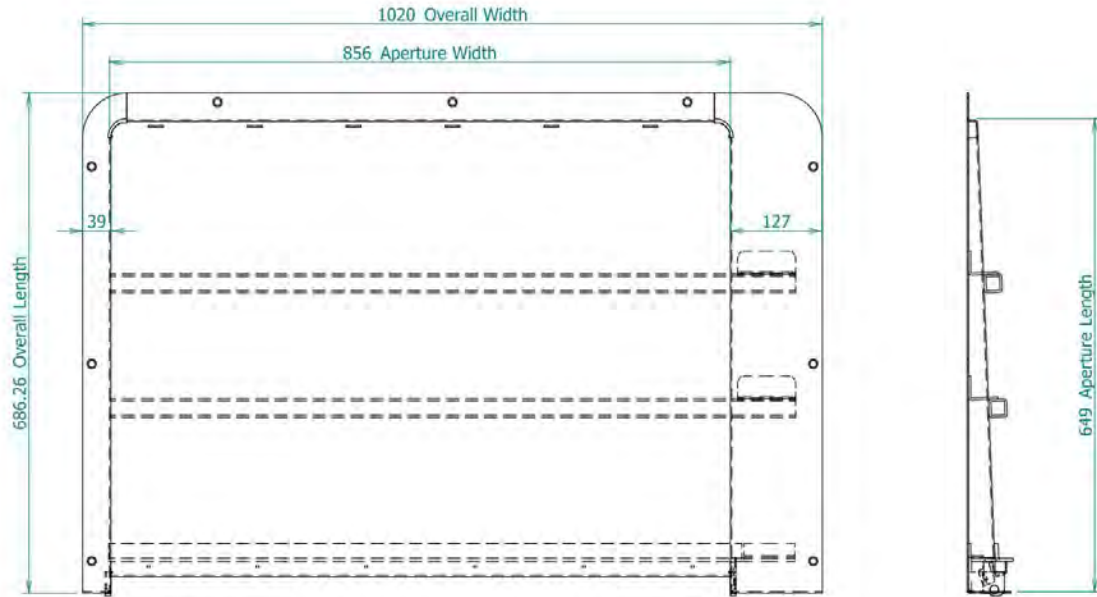

*PSV UK and EU Compliant Manual Ramp Narrow

Visit www.psv-transport-systems.co.uk

- Thousands of product images
- Over 60,000 cross references
- Technical and specification data
- Continually updated

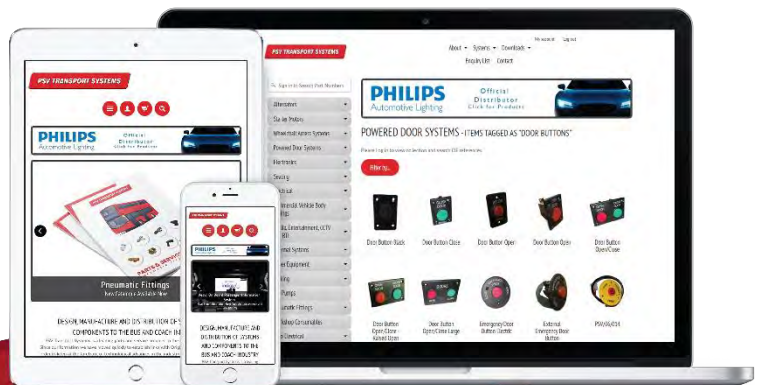

PSV Optare Specified Manual Ramp

This ramp was developed specifically for use on Optare vehicles that feature a 'kinked' floor. The design of the ramp allows both the moving member and the cassette to follow the shape of the floor.

Following a successful trial, PSV ramps were specified on every new bus ordered by a leading UK operator. Because of the unique floor on some Optare vehicles the standard PSV product was not compatible. The ramp is a good example of the custom operator and bus builder requirements that PSV are able to work with.

Key Features

- Conforms to current UK and EU Regulations
- Cassette style design
- 'Kinked' design to allow integral floor
- Safe working load 300Kg
- Fully retractable bungee style handle
- Light-weight construction
- Concealed maintenance free pivots
- Posture friendly deployment
- Can be manufactured in a range of sizes to suit step height

Key Benefits

- Lighter than existing market alternatives
- Strong, robust, metal frame
- Avoids splintering associated with other composite boards
- Impact damage resistant

Safety Features

- Safety interlock
- High visibility edges
- Anti-slip surface



*Illustration to show taper in ramp leaf

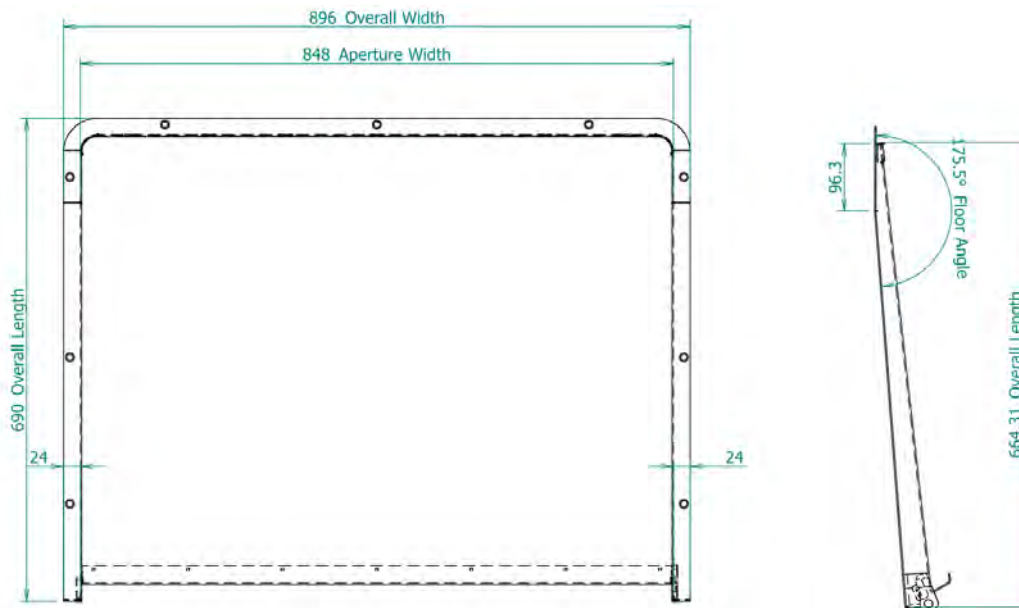

OE MANUAL RAMPS

1.3

OE MANUAL RAMPS

PSV Fixed Floor Two Stage Telescopic Powered Ramp 2nd Generation



This two stage ramp draws upon strengths of the first generation PSV two stage telescopic powered ramp. It has a no step 'Single Plain' between boards which results in a reduced weight when compared to other market alternatives.

We introduced the fully electric two stage ramp to give operators the same maintenance benefits of our single stage ramp whilst decreasing the ramp operating angle for wheelchair users.

Like the first generation ramp, this Telescopic Powered Ramp is designed with a sacrificial front edge which aids in reducing impact damage. New to the second generation ramp is a redesigned flap and seal which further reduces dirt and water ingress.

The top of the ramp is now flat for easier installation. We have also added self-lubricating sliders to further reduce the maintenance requirement

Key Features

- Conforms to current UK and EU Regulations
- To suit 250mm and 270mm step height dependant on chassis type
- Fixed Floor Design
- Reduced weight vs market alternatives
- Low upstanding threshold
- Cassette style design
- Multiplex compatible
- Single motor and fully electric
- Front accessible fixings for easy cassette removal
- Manual deployment in the event of power failure
- Easy retrofit
- Safe working load 300Kg, Proof tested to 450Kg
- Non corrosive components
- Aluminium Board
- Quick change sacrificial edge
- Self-lubricating sliders
- Direct drive deployment mechanism

Safety Features:

- Sensing leading edge
- Sensing down force
- Safety Interlock

Key Benefits:

- Simple removal of ramp cassette without affecting vehicle floor
- Flat cassette design for ease of installation
- Under 10 minutes to remove ramp
- Electric powered alleviating pneumatic control problems
- Simplified design with minimal moving components
- Low power consumption
- Installation requires no chassis modification
- Sacrificial front edge reduces impact damage
- Direct drive mechanism means no adjustment is required



The PSV Telescopic Ramp was developed to outperform existing ramps in the market and provide Operators with greater reliability and serviceability when in operation.

The Telescopic Ramp is fitted as OE by many Bus Builders and is notably the OE Powered ramp on the New Bus for London.

The ramp is operated by electricity only and reduces the common failures and spare parts usage associated with pneumatic/electric alternatives.

Key Features

- Conforms to current UK and EU regulations
- Cassette style design
- Single stage
- Integral floor
- Multiplex compatible
- Electric powered
- Manual deployment in the event of a power failure
- Quick change sacrificial front edge
- Easy Retro-fit
- Safe working load 300Kg

Safety Features

- Audible warning
- Positive sensing leading edge
- Positive sensing down force
- Safety interlock

Key Benefits

- Simple removal of ramp cassette without affecting vehicle floor
- Electric powered alleviating pneumatic control problems
- Simplified design with minimal moving components
- Low power consumption
- Installation requires no chassis modification
- Suspended drive to avoid dirt ingress
- Sacrificial front edge reduces impact damage

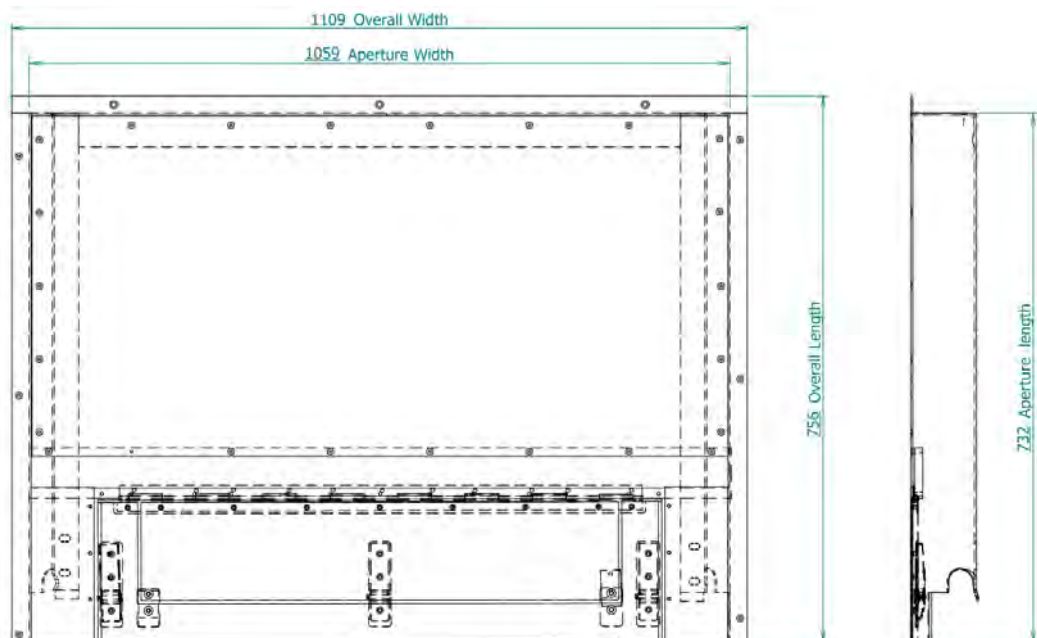

*PSV Single Stage Telescopic Ramp Short

OE POWERED RAMPS

1.5

OE POWERED RAMPS

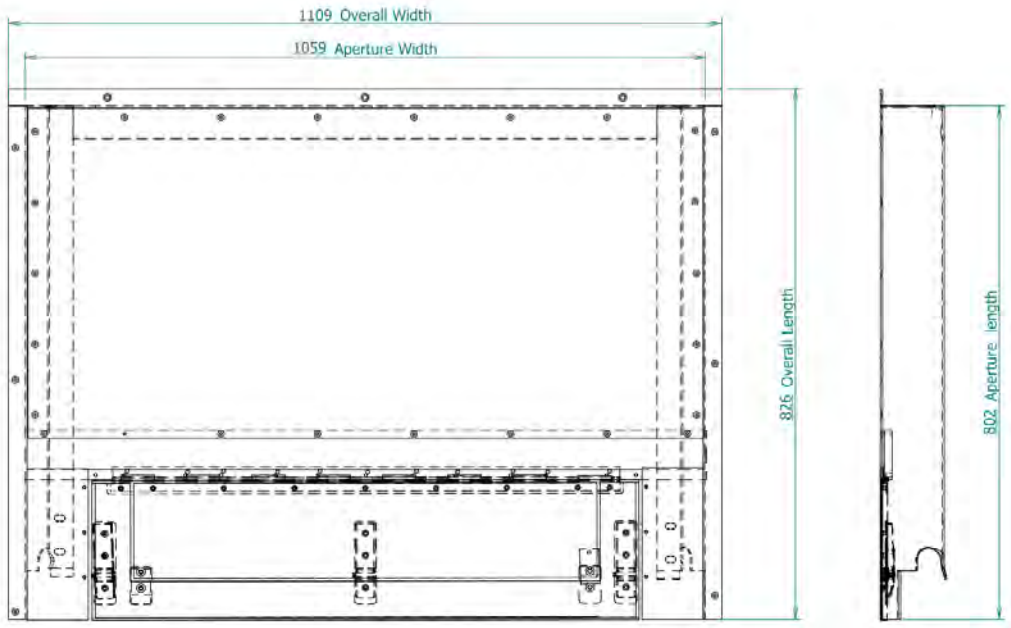

*PSV Single Stage Telescopic Ramp Long

PSV Single Stage Telescopic Ramp Fixed Floor

PSV Two Stage Telescopic Ramp Fixed Floor

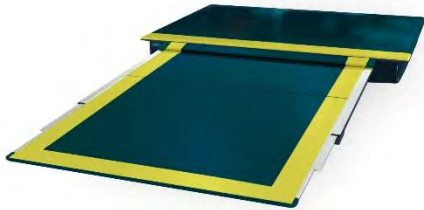
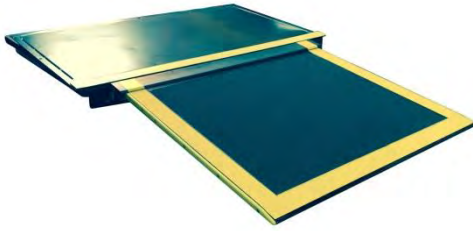

*Front Accessible Non-corrosive components

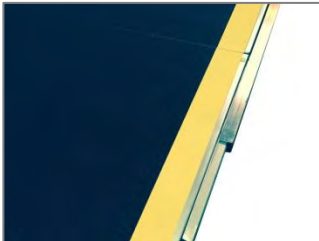

*Single Plain (Two Stage Ramp)



*Single Plain (Two Stage Ramp)



*Replaceable Sacrificial front edge

Single Stage Powered Telescopic Ramp (Fixed Floor)

- Single Stage
- Draws upon strengths of existing PSV Ramps
- Ramp length can be varied to suit Operator requirements
- Reduced weight vs market alternatives (60kg)

Two Stage Powered Telescopic Ramp (Fixed Floor)

- Two Stage
- Draws upon strengths of existing PSV Ramps
- No Step 'Single Plain' between boards
- Reduced weight vs market alternatives (65kg)
- Specified on the New Bus for London (MK2)

Key Features

- Conforms to current UK and EU regulations
- To suit 250mm – 270mm step height dependent on chassis type
- Fixed floor design
- Reduced Weight vs market alternatives
- Low upstanding threshold
- Cassette style design
- Multiplex Compatible
- Fully Electric
- Single Motor
- Manual Deployment in the event of power failure
- Easy retrofit
- Safe working load 300kg, Proof Tested to 450kg
- Non corrosive components
- Aluminium board
- Quick change sacrificial front edge
- Front accessible fixings for easy cassette removal
- Direct drive deployment mechanism

Safety Features

- Audible Warning
- Sensing leading edge
- Sensing down force
- Safety interlock

Key Benefits

- Simple removal of ramp cassette without affecting vehicle floor
- Under 10 minutes to remove ramp
- Electric Powered alleviating pneumatic control problems
- Simplified design with minimal moving components
- Low power consumption
- Installation requires no chassis modification
- Sacrificial front edge reduces impact damage
- Direct Drive mechanism means no adjustment is required

OE POWERED RAMPS

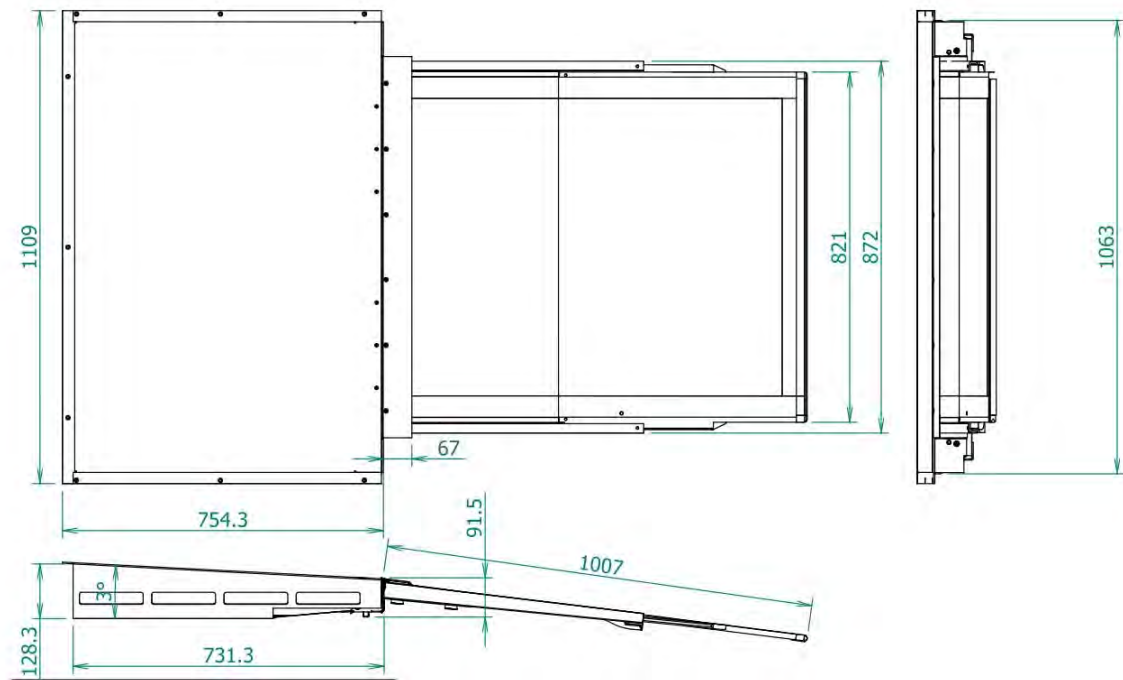

*PSV 2 Stage Telescopic Ramp with Fixed Floor

Can't find what you're looking for or unsure of an application?

Contact a member of our sales team and we'll be happy to help. Our cross reference database includes thousands of vehicle manufacturer and original equipment references



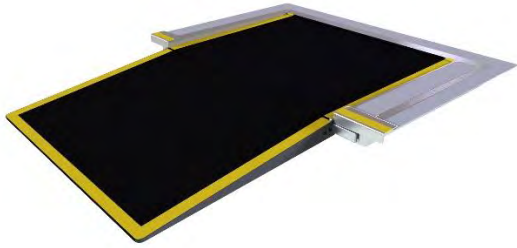

Low-Floor City Bus Powered Composite Bookleaf Ramp

PSV's electric powered composite bookleaf ramp was developed for a leading bus body builder. The builder's requirement was for a powered bookleaf ramp but due to the width and depth constraints of the vehicle PSV's standard ramp could not be used. We therefore designed a new version of our bookleaf ramp to fit the same footprint as our existing composite manual ramps. The ramp features a steel surround frame and composite moving member meaning reduced weight vs our full steel version.

The ramp is ideal for any operator with a requirement for a powered access ramp in restricted space.

Key Features:

- Conforms to Current UK and EU Regulations
- Single Stage
- Integral Floor
- Multiplex Compatible
- Electric Powered
- Manual Deployment in the event of power failure
- Easy Retro Fit
- Safe Working Load 300Kg
- Fits same footprint as existing composite manual ramps

Safety Features:

- Safety Interlock
- High Visibility Edges
- Audible Warning
- Safety Sensing

Key Benefits:

- Fully Electric Powered
- Reduced weight composite moving member
- Ease of Maintenance

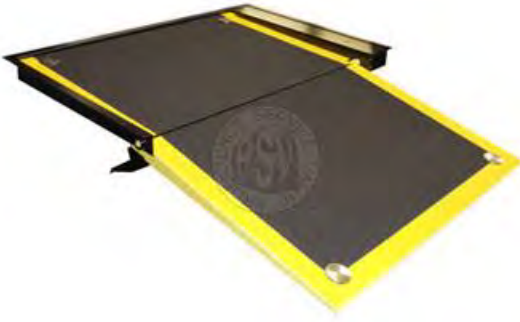

UK and EU Compliant Bookleaf Ramp

PSV's UK and EU Compliant Bookleaf powered ramp was developed for a leading operator in Southern Ireland. The operator originally specified the Deans Bookleaf ramp but due to newly introduced European Regulations this ramp was no longer compliant. Due to demand from the operator PSV redeveloped and redesigned the Bookleaf ramp in order to comply with all regulations.

Key Features

- Conforms to current UK and EU Regulations
- Single stage
- Integral floor
- Multiplex compatible
- Electric powered
- Manual deployment in the event of power failure
- Easy retro-fit
- Safe working load 300Kg

Safety Features

- Audible warning
- Safety sensing
- Safety interlock

Key Benefits

- Electric powered alleviating pneumatic control problems
- Draws on strengths of existing tried and tested Deans product
- Simplified design
- Ease of maintenance

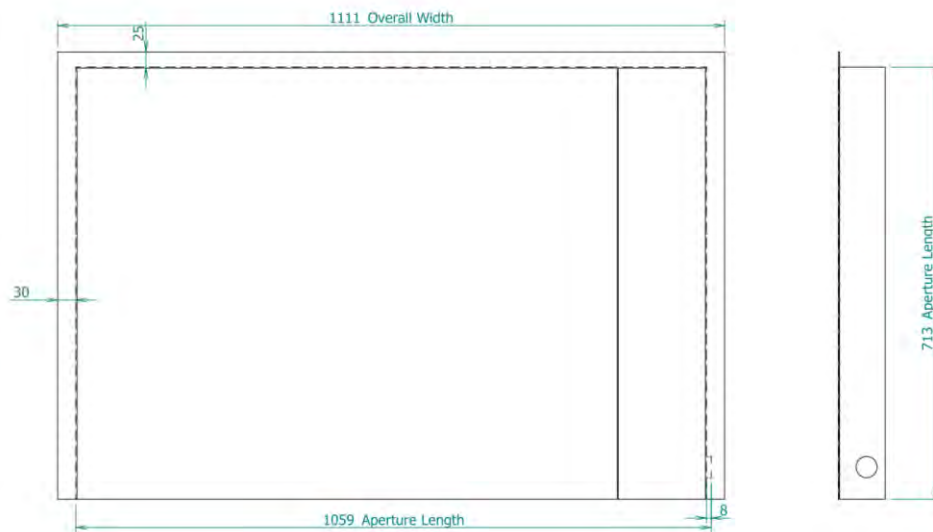

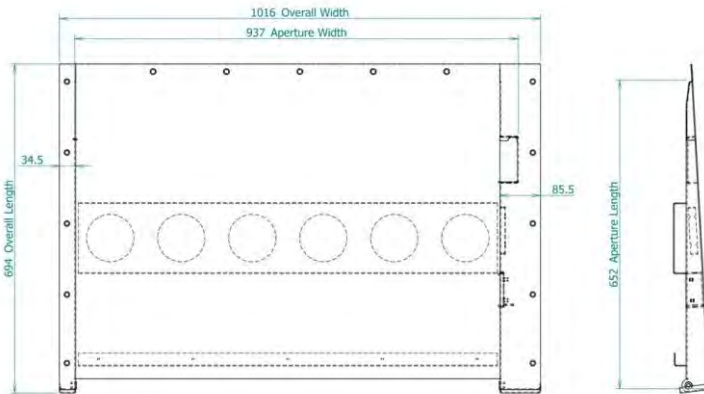
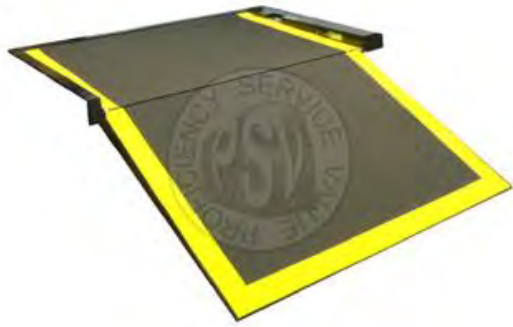

PSV000001 – PSV Compak Replacement Manual Ramp

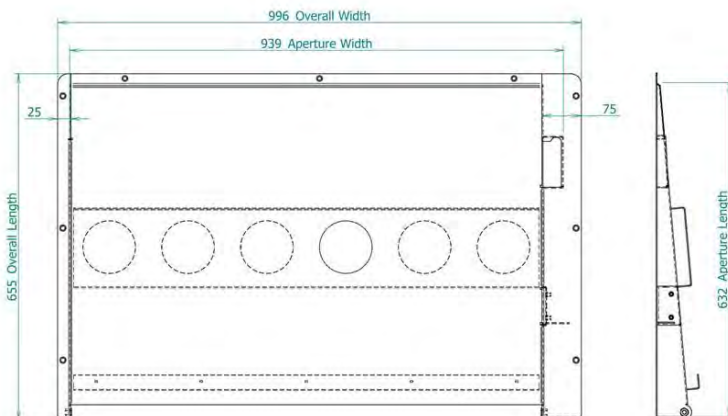

PSV000003 – PSV 3 Degree Manual Ramp

PSV Aftermarket Manual Ramps

PSV Aftermarket Manual Ramps are based on the original OE Deans Systems and Peters Door Systems ramp design. The ramp cassette is available in a range of different sizes with fixing points to suit operator requirements. This ramp has been particularly popular with operators and vehicle conversion specialists who need to ensure DDA compliance. DDA standards stipulate that a vehicle must have a wheelchair access ramp. The deadlines are:

1st January 2015 – All buses and coaches up to 7.5 tonnes GVW

1st January 2016 – Single-deck buses over 7.5 tonnes GVW

1st January 2017 – Double-deck buses

1st January 2020 - Coaches

Sizes Available

- Compak Replacement; Identical size and fixing points to replace Compak CP6 manual ramps
- Electric Bookleaf Replacement; Wider cassette to convert vehicles with powered ramps to manual
- Various sizes to replace or convert existing ramps
- Sizes to suit vehicles that currently have no ramp to ensure DDA compliance
- Sizes to suit centre door conversions for cascade of ex-London vehicles.

Key Features

- Manufactured to original Deans specifications with upgrade to handle
- Robust metal frame and top board
- Light weight construction
- Retractable handle
- Concealed Stainless Steel maintenance free pivot points
- Posture friendly deployment
- Safe working load 300Kg

Safety Features

- Safety Interlock
- Anti-slip surface
- High visibility edges

Key Benefits

- Uses strengths of original Deans OE specified manual ramp
- Robust metal frame avoids splintering and limits impact damage associated with some composite material products
- Easy to use, fully retractable handle
- Reduced risk of back injury with bungee style handle
- Manufactured on-site with minimal lead

AFTERMARKET RAMPS

1.11

AFTERMARKET RAMP

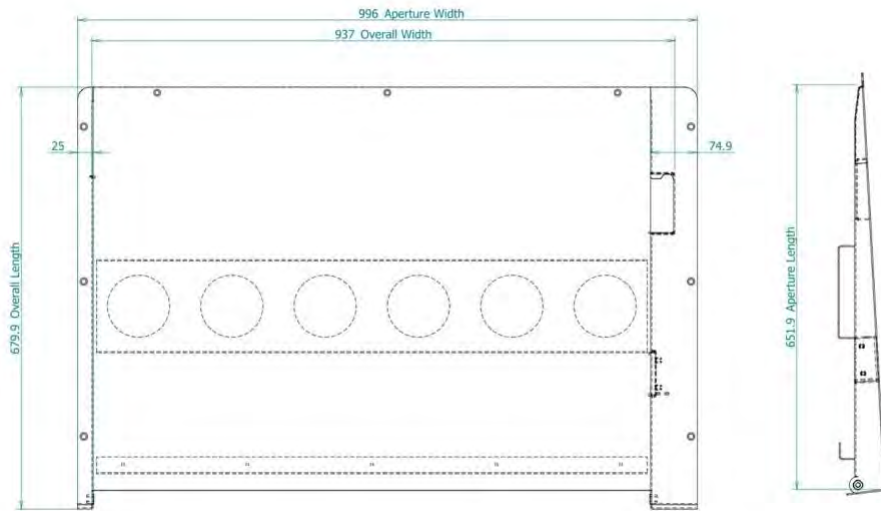

PSV000002 – PSV 5 Degree Manual Ramp

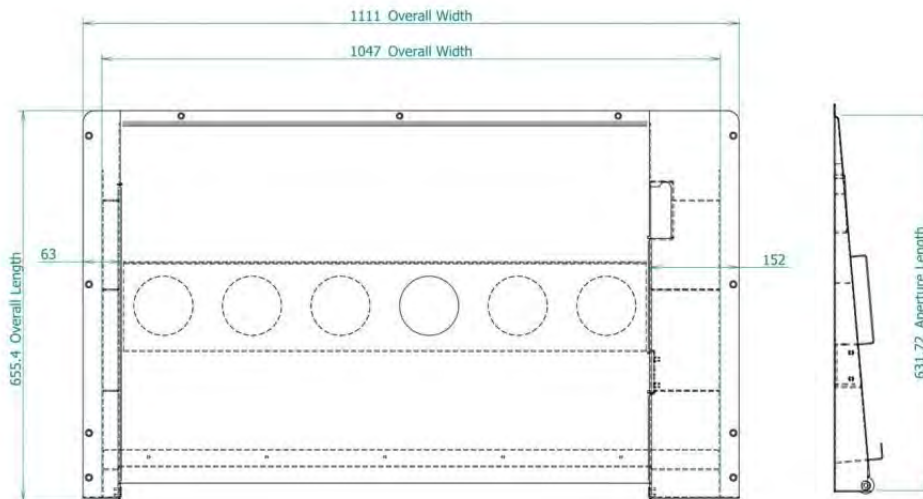

PSV000004 – PSV Electric Bookleaf Replacement Manual Ramp

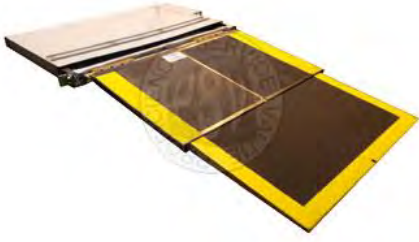

Compak CP5 Upgrade Powered Ramp

Part No	Description
PSV/04/009	Ramp

- Available as new from PSV
- Available as Service Exchange
- Service exchange stock kept at PSV
- Can be priced by price of repair or flat repair rate
- Complete spare parts portfolio available

Contact PSV for more information



Compak CP2 Powered Ramp

Part No	Description
PSV/04/007	4 Wire
PSV/04/008	6 Wire

- Available as new from PSV
- Available as Service Exchange
- Service exchange stock kept at PSV
- Can be priced by price of repair or flat repair rate
- Complete spare parts portfolio available

Contact PSV for more information

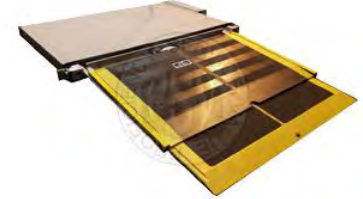

Compak Powered Ramp

Part No	Description
PSV/04/003	CP1 4 Wire
PSV/04/004	CP1 6 Wire
PSV/04/005	CP5 4 Wire
PSV/04/006	CP5 6 Wire

- Available as new from PSV
- Available as Service Exchange
- Service exchange stock kept at PSV
- Can be priced by price of repair or flat repair rate
- Complete spare parts portfolio available

Contact PSV for more information

AFTERMARKET RAMPS

1.13