

CRETE

Square

Concrete Propane Tank Enclosure

18" W x 18" L x 22.5" H



WWW.CRETE.DESIGN

Square

Concrete Propane Tank Enclosure

Heat-resistant glass fiber reinforced concrete conceals your propane tank even while it's in use. Coordinates with our line of fire tables/bowls.

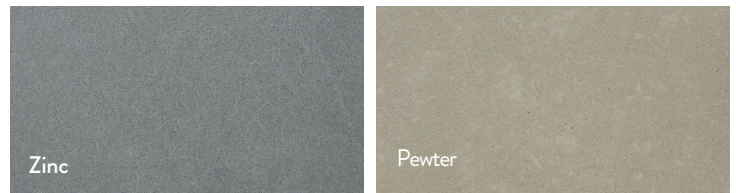
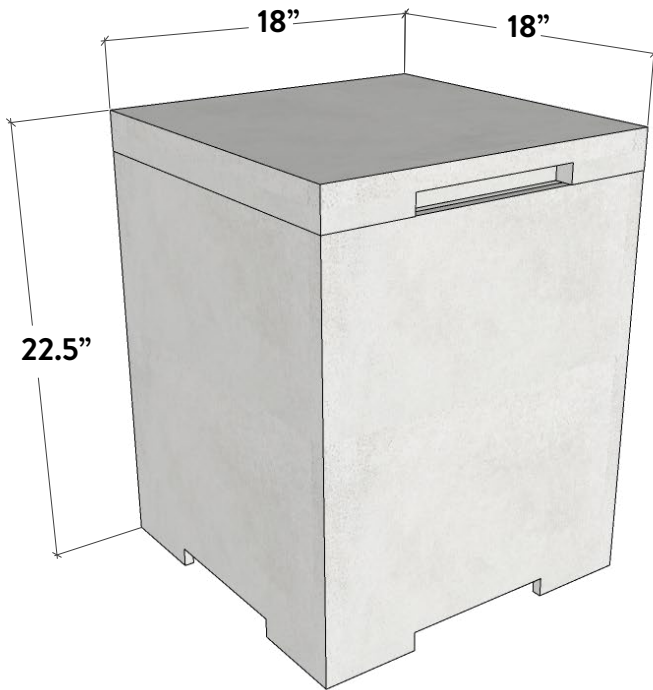

Weight

Total 85lb



715-293-3101

info@crete.design

Compliant with the following codes:

1. 2021, 2018, 2015, 2012, and 2009 International Fire Code ©(IFC)
2. 2021, 2018, 2015, 2012, and 2009 International Fuel Gas Code ©(IFGC)
3. 2018, 2015, 2012, and 2009 Uniform Mechanical Code © (UMC)*
4. 2020, 2015, and 2010 Natural Gas and Propane Installation Code**

Compliant with the following standards:

1. ANSI Z21.97/CSA 2.41-2017 Outdoor Decorative Gas Appliances
- * Uniform Plumbing code is a copyrighted publication of the International Association of plumbing and Mechanical Officials.
**Copyrighted publication of Canadian Standard Association.