



NP400

RELATIVE PRESSURE TRANSMITTER – INSTRUCTION MANUAL – V1.0x G

INTRODUCTION

NP400 positive relative pressure transmitters are robust and reliable equipment suitable for general industrial applications. They are available in several measurement ranges and process connection modes.

PRECAUTION

Before operating the transmitter, carefully read its specifications and operating instructions. In case of damage caused by incorrect operation or inappropriate usage, warranty becomes null and void.

The installation must be carried out by a specialized professional.

The electronic instruments power supply must come from a proper instrumentation network.

UNPACKING

When unpacking, in addition to the transmitter itself, you should find:

- A quick guide to installation and operation.
- A sealed electrical connector.
- A screw to fix the connector to the transmitter.

IDENTIFICATION

An identification label is attached to the equipment housing. On this label, you can find detailed information about the transmitter.

Figure 1 shows the identification label:

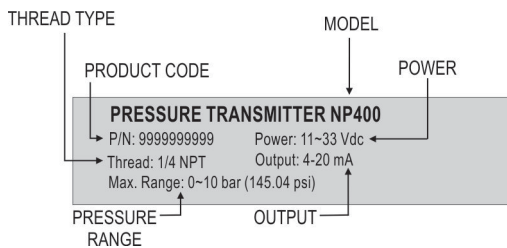

Figure 1 – Transmitter identification

SPECIFICATIONS

Reference Conditions:

Environment at 23 °C ± 3 °C, 24 V supply, 250 Ω load. Vertical position (pressure connection is down).

Measurement Type:

Positive relative pressure.

Pressure Range:

Pressure Transmitter Nominal Pressure	Overpressure	Burst Pressure
0.2 MPa (2 bar / 29.01 psi)	0.24 MPa (2.4 bar / 34.81 psi)	0.5 MPa (5 bar / 72.52 psi)
0.5 MPa (5 bar / 72.52 psi)	0.6 MPa (6 bar / 87.02 psi)	1.25 MPa (12.5 bar / 181.29 psi)
1 MPa (10 bar / 145.04 psi)	1.2 MPa (12 bar / 174.04 psi)	2.5 MPa (25 bar / 362.59 psi)
1.6 MPa (16 bar / 232.06 psi)	2.4 MPa (24 bar / 348.09 psi)	5 MPa (50 bar / 725.19 psi)
2 MPa (20 bar / 290.08 psi)	2.4 MPa (24 bar / 348.09 psi)	6 MPa (60 bar / 870.23 psi)
2.5 MPa (25 bar / 362.59 psi)	3.6 MPa (36 bar / 522.13 psi)	9 MPa (90 bar / 1305.33 psi)
4 MPa (40 bar / 580.15 psi)	4.8 MPa (48 bar / 696.18 psi)	10 MPa (100 bar / 1450.38 psi)
5 MPa (50 bar / 725.19 psi)	6 MPa (60 bar / 870.23 psi)	12.5 MPa (125 bar / 1812.97 psi)
6 MPa (60 bar / 870.23 psi)	12 MPa (120 bar / 1740.45 psi)	20 MPa (200 bar / 2900.75 psi)
10 MPa (100 bar / 1450.38 psi)	12 MPa (120 bar / 1740.45 psi)	20 MPa (200 bar / 2900.75 psi)
16 MPa (160 bar / 2320.60 psi)	24 MPa (240 bar / 3480.91 psi)	35 MPa (350 bar / 5076.32 psi)
25 MPa (250 bar / 3625.94 psi)	36 MPa (360 bar / 5221.36 psi)	45 MPa (450 bar / 6526.69 psi)
40 MPa (400 bar / 5801.51 psi)	48 MPa (480 bar / 6961.81 psi)	55 MPa (550 bar / 7977.07 psi)

Table 1 – Measurement ranges

Measurement Accuracy:

NP400 (< 50 bar) < ± 0.5 % F.S.

NP400 (>= 50 bar) < ± 1.0 % F.S.

Maximum Thermal Deviation:

< ± 0.06 % of Maximum Range / °C.

Including zero and span deviations.

Influence of the mounting position:

< 0.001 % of Maximum Range / °C.

Output signal (Output):

Electric current, 4-20 mA, 2 wires.
Maximum current < 21.5 mA.

Resolution:

< 0.1 % of Maximum Range.

Power supply (Power):

11 to 33 Vdc

Maximum load (RL):

$RL = (V_{dc} - 11) / 20 \text{ mA } (\Omega)$

Where: Vdc = Power supply voltage

Electrical connection:

Connector for Type A valves (DIN EN 175301-803), IP65.

Conductor 1.5 mm² (max.) and cables between 6 and 8 mm in diameter.

Operating temperature:

-20 to 70 °C (-4 to 158 °F)

Medium temperature:

-20 to 100 °C (-4 to 212 °F)

Storage temperature:

-40 to 70 °C (-40 to 158 °F)

Dynamic response:

< 1 ms

Process connection (Thread):

¼ NPT; ½ NPT; ½ BSP; G ¼ (*)

Sensor features:

Piezoresistive – Thick Film on Ceramics (Al₂O₃ 96 %).

Metal housing of the transmitter:

Stainless steel 316.

Wetted parts:

Sensor Ceramic, Al₂O₃ 96 %.

Sealing Ring, FKM.

Metal Connection, stainless steel 316.

Compatibility: Any gas or liquid compatible with the constituent materials of the wetted parts.

Certification: CE

(*) Information available on the product identification label.

Note: For models with process connection ½ BSP and G ¼, the outer seals are manufactured with FKM.

ELECTRICAL CONNECTIONS

Figure 2 – Electrical connections

Installation recommendations

- The instruments must be powered from a dedicated instrumentation power supply.
- It is strongly recommended to apply RC'S FILTERS (noise suppressor) to contactor coils, solenoids, etc.
- To improve measurement stability, immunity, and safety, it is recommended to use system grounding.

DIMENSIONS

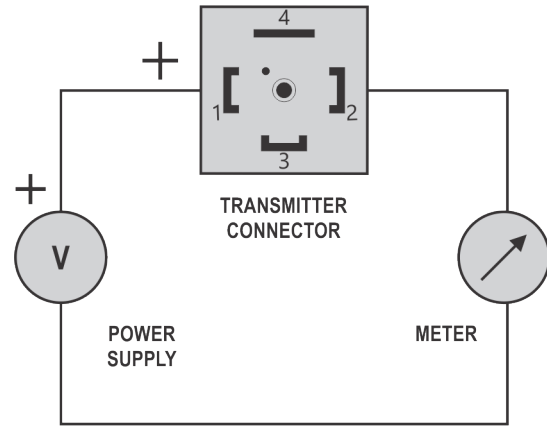
Figure 3 – Transmitter dimensions

Note: Previous versions (2020) have other measures.

THREAD	A (mm)	B (mm)	WEIGHT (g)
NPT ¼	15.5	51.0	106
NPT ½	20.0	56.5	159
BSP ½	14.0	49.5	121
G ¼	14.0	49.5	105

Table 2 – Transmitter thread type, dimensions, and weight

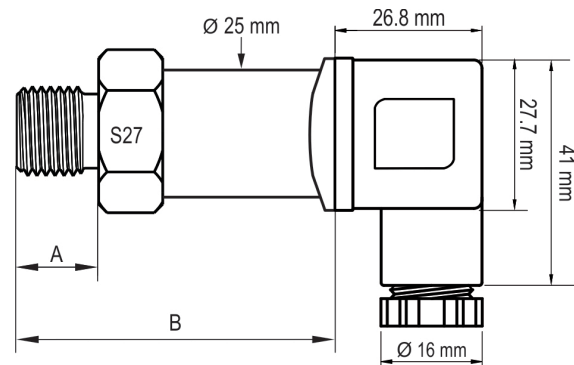
WARRANTY

Warranty conditions are on our website
www.novusautomation.com/warranty.