



LASER LEVEL TRANSMITTER

TL400-I

DATASHEET – V1.0x

INTRODUCTION

TL400-I is a non-intrusive level transmitter with no moving parts, using an infrared laser technology (~920 nm) that is completely safe to the human eye (LASER CLASS-1). Its measurement principle is based on ToF (Time of Flight), providing an accurate and reliable distance measurement, regardless of the color or transparency of the surface¹. It can be used to measure from grains and solids to transparent liquids such as water and diesel.

It has a robust housing, withstanding pressures up to 8 bar, and excellent resistance to flammable materials such as diesel, gasoline, or alcohol.

With a measurement capacity up to 4 meters and 1 Hz sampling, **TL400-I** is an excellent alternative to level sensors based on ultrasonic, capacitive, or floating technology since it does not need to be in contact with the surface to be measured.

The transmitter has a dedicated filter for non-static tank applications based on machine learning algorithms that have been validated in real-life situations and have configurable parameters for specific applications.

The sensor allows you to configure the opening angle, ranging from 12° degrees for irregular tank or reservoir applications to 27° degrees for tanks where the base diameter is half the height to be measured.

TL400-I has a BLE (Bluetooth Low Energy) interface. With it you can:

- Configure the **analog output** (4-20 mA), according to the specific application
- Configure the **opening angle** of the sensor (from 12° to 27° opening degrees)
- Customize the tank with up to 20 points in level percentage
- Perform sensor **diagnostics** in real time
- Configure the dynamic **filter** based on the application
- Update the **firmware** to the most current version, which will always be available on **NOVUS** website

These functions can be adjusted through the **SigNow** app, available for Android and iOS.

The sensor can retransmit the analog output in **Level**, **Volume**, or **Distance**. Level and distance are set in your preferred unit (mm, cm, m, inches, or feet) and volume is always displayed in percent.

The figure below shows **TL400-I** in an application:

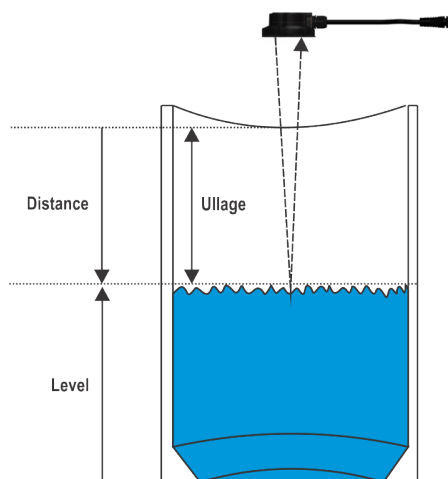

Figure 1 – TL400-I installation

¹ In sunlit environments or in small to medium sized tanks that have reflective walls, the sensor may have difficulty to make an accurate measurement. See recommendations for use and application.

DIMENSIONS

TL400-I

The figures below show the dimensions of the TL400-I and an overview of the equipment:

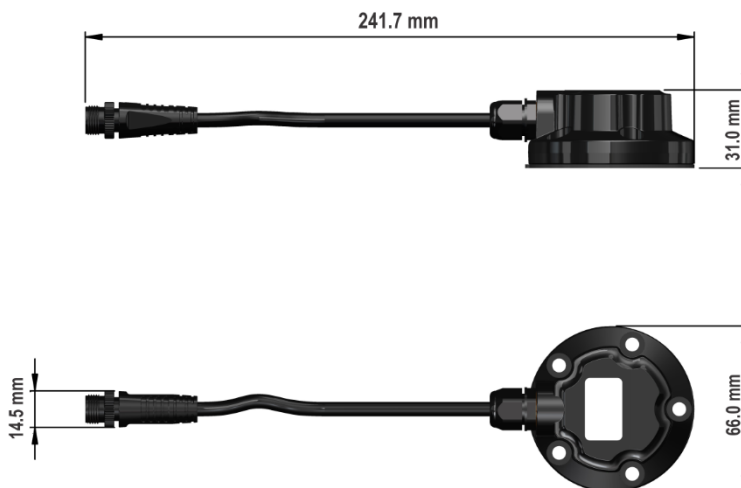

Figure 2 – TL400-I dimensions

5-HOLE TO 4-HOLE ADAPTER

The figure below shows the dimensions and drilling of the adapter for attaching the equipment:

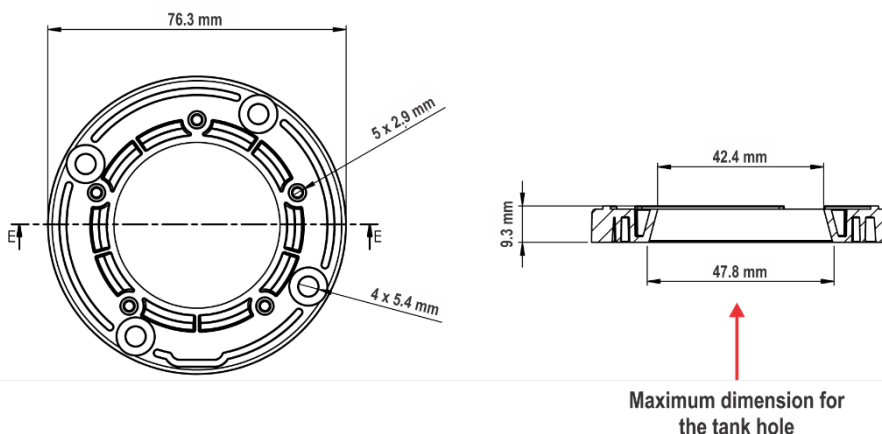

Figure 3 – Adapter

ELECTRICAL CONNECTIONS

The figure below shows how to make the electrical connection of the equipment:

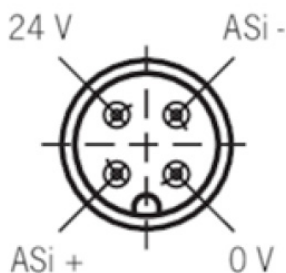

Figure 4 – Electrical connections

INSTALLATION RECOMMENDATIONS

- Electronic and analog signal drivers must run the plant separately from the output and power leads. If possible, in grounded conduits.
- The power supply for the electronic instruments must come from a proper power grid for instrumentation.
- It is recommended to use RC FILTERS (noise suppressors) in contactor coils, solenoids, etc.
- In control applications, it is essential to consider what can happen when any part of the system fails. The device internal security features do not guarantee full protection.

TECHNICAL SPECIFICATIONS

FEATURES	TL400-I
Dimensions	241.7 x 66 x 31 mm
Distance Measurement	Configurable from 0 to 4000 mm.
Resolution	0.1 % F.S. up to 2 meters and 1 % up to 4 meters.
Sampling	1 Hz
Connector	M12 with 4 pins (Vcc, GND, ASi+, ASi-).
Output	4-20 mA with 0.1 mA resolution.
Assembly	Standard SAE 5 holes or adapter for standard 4 holes.
Consumption	<70 mA @ 12 V or <40 mA @ 24 V
Power Supply	8 – 33 Vdc
Storage Temperature	-20 to 80 °C
Operation Temperature	-20 to 80 °C
Protection Index	IP68
Housing	Polycarbonate
Configuration Application	SigNow (for smartphones)
Certifications	CE, FCC, Anatel (13883-22-07089), UKCA, LASER CLASS 1

Table 1 – Technical specifications

CERTIFICATIONS

FCC

This equipment has been tested and found to comply with the limits for a Class A digital device, pursuant to Part 15 of the FCC Rules. These limits are designed to provide reasonable protection against harmful interference when the equipment is operated in a commercial environment. This equipment generates, uses, and can radiate radio frequency energy and, if not installed and used in accordance with the instruction manual, may cause harmful interference to radio communications.

Any changes or modifications not expressly approved by the party responsible for compliance could void the user's authority to operate this equipment.

RF Exposure: 20 cm shall be maintained between the antenna and users, and the transmitter module may not be co-located with any other transmitter or antenna.

This device complies with part 15 of the FCC Rules. Operation is subject to the following two conditions: (1) This device may not cause harmful interference, and (2) this device must accept any interference received, including interference that may cause undesired operation.

CE MARK / UKCA

This is a Class A product. In a domestic environment, this product may cause radio interference in which case the user may be required to take adequate measures.

LASER CLASS 1

The radiation used by the sensor is classified by IEC 60825-1:2014 as CLASS 1 LASER PRODUCT and does not present a risk to the human eye as long as you do not make any changes not described in the manual.

ANATEL

This device is homologated by ANATEL, according to the regulated procedures for conformity assessment of telecommunications products, and meets the technical requirements applied.

This equipment is not subject to the protection from harmful interference and may not cause interference with duly authorized systems.

For more information, see the ANATEL website www.anatel.gov.br.

WARRANTY

Warranty conditions are available on our website www.novusautomation.com/warranty.