

Espedeo Supra-5000

The award-winning cinema projector designed for mini-theatres
Perfect for the cinematic experience at home and at sea



Best New Auditorium Technology
CTC Awards 2021



reddot winner 2020

Ideal for boothless



Quiet



Light



Small



Ceiling
mount



No
hush-box

The Espedeo Supra-5000 is a DCI-compliant projection system featuring ALPD 4.0 RGB+ laser phosphor technology to deliver vibrant colors. The Supra-5000 is compact, lightweight and quiet with a noise level below 35dB(A) making it an ideal digital cinema solution for boothless mini-theatres.

Now it is possible to build a mini-theatre with fewer construction constraints and FF&E costs, even with a ceiling height as low as 3 meters (10 feet). The Supra-5000 is so compact that it does not require a standard projection booth. By facilitating VESA ceiling mount Espedeo VM-1140 without a hush-box, the Supra-5000 also opens the door for non-traditional exhibition options such as hotels, screening rooms and yachts.

With its unique design, the small form factor of the Supra-5000 is achieved with GDC's All-in-One Board (DCI-compliant media server, Integrated Cinema Processor [ICP] and DMD formatter board) to help lower the total cost of ownership, and improve reliability and serviceability. With GDC's All-in-One Board, the Supra-5000 is compliant with Hollywood's digital right management based on digital cinema's KDM and DCP playback.

The Supra-5000 demonstrates the best possible projection system for mini-theatres and alternative venues from renowned technologists: Appotronics, GDC and Texas Instruments.

Features

- 1 Specifically designed for in-auditorium ceiling mount (no hush box). It is smaller, lighter and quieter when compared to other cinema projectors with the same brightness level.
- 2 Air cooled without exhaust.
- 3 RGB+ laser phosphor digital cinema projector with the world's leading ALPD 4.0 technology, achieving 99% of Rec.2020 color gamut.
- 4 Light engine and lens are designed with IP5X level of dustproof protection for maximizing brightness.
- 5 Lumens output: 5000 lumens with DCI colors.
- 6 The only DCI professional-grade projector that does not require hazard zone clearance from the viewers and allows full utilization of the auditorium seating area. The Supra-5000 is certified as Risk Group 2 making it safe for commercial cinemas, homes and offices.
- 7 Affordable DCI-compliant projection system offering amongst the lowest TCO thanks to its architecture and advanced technology.
- 8 Built-in GDC's All-in-One-Board, which is designed with near-zero maintenance electronics and 100,000 hours Mean Time Between Failures (MTBF).
- 9 Supports 3D playback with Espedeo PM-2000B 3D Polarized System measuring over 30% light efficiency.
- 10 GDC's All-in-One Board provides diskless CineCache™ (built-in cache memory). Content ingest and playback can be performed concurrently without local HDD storage. Incredibly fast ingest during playback.
- 11 Supports GDC Cinema Automation CA2.0 that stores and enables the playback of thousands of movies and auto power-on/power-off for projector's laser according to the pre-set schedules.*
- 12 The Supra-5000 offers various built-in options for a 5.1 / 7.1 / 15.1 cinema audio processor and a 16-channel DTS:X™ decoder** that supports SMPTE ST 2098-2 immersive audio bitstream (IAB) standard. The Supra-5000 offers the capability to reproduce an incredibly deep, rich listening experience designed for 5.1 and 7.1 PCM uncompressed surround sound functionality. When the Supra-5000 featuring DTS:X Solution with IAB support, audiences can immerse themselves with object-based audio technology for a 360° audio experience.

Espedeo offers an optional Audio IO (Input-Output) Box for Supra-5000, with a built-in 8-channel premium quality digital-to-analog converter (DAC), to interface with external audio equipment such as analog amplifiers, booth monitor, microphone, and media players. Espedeo also offers a 16-channel DAC option for analog output.
- 13 Supra Command Center: an intuitive web-based control UI connected to the projector's built-in Wi-Fi or management network that can be accessed with a desktop, a laptop or a tablet.
- 14 Option to customize the magnetic cover to match with your ceiling color.

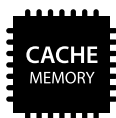

featuring



* Please visit www.gdc-tech.com for Cinema Automation CA2.0. Note: tablet or handheld device required but not included.
** HI/VI output is not available when outputting more than 14 channels of DTS: X audio

Perfect for mini-theatres, boothless no hush-box installation

Patent Pending

Accessories for Supra-5000



1.58-2.49:1 lens



1.28-1.92:1 lens



0.8:1 lens



Espedeo PM-2000B 3D polarized system and glasses



Espedeo VM-1140 VESA ceiling mount
(another compatible projector ceiling mount can be sourced from Legrand)

Option to customize the magnetic cover to match with your ceiling color

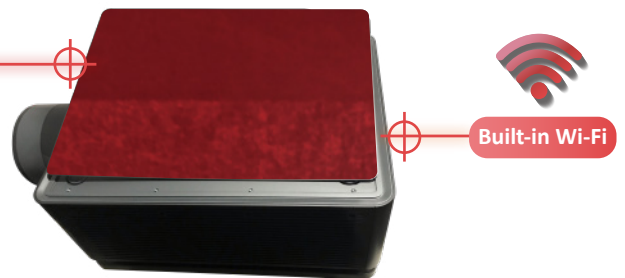
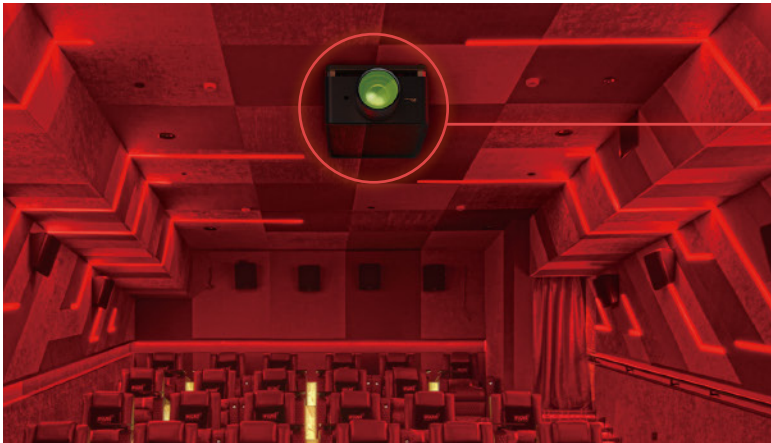

Supra Command Center

- Integrated projector and media-player control
- Screen setup and management
- Cinema Automation setup
- Show scheduling with auto-playlist
- Intuitive web-based user interface accessible via compatible web-browser on PC, MAC, Android or iOS devices



Built-in Professional 5.1 / 7.1 / 15.1 Cinema Audio Processor with digital or analog amplifiers

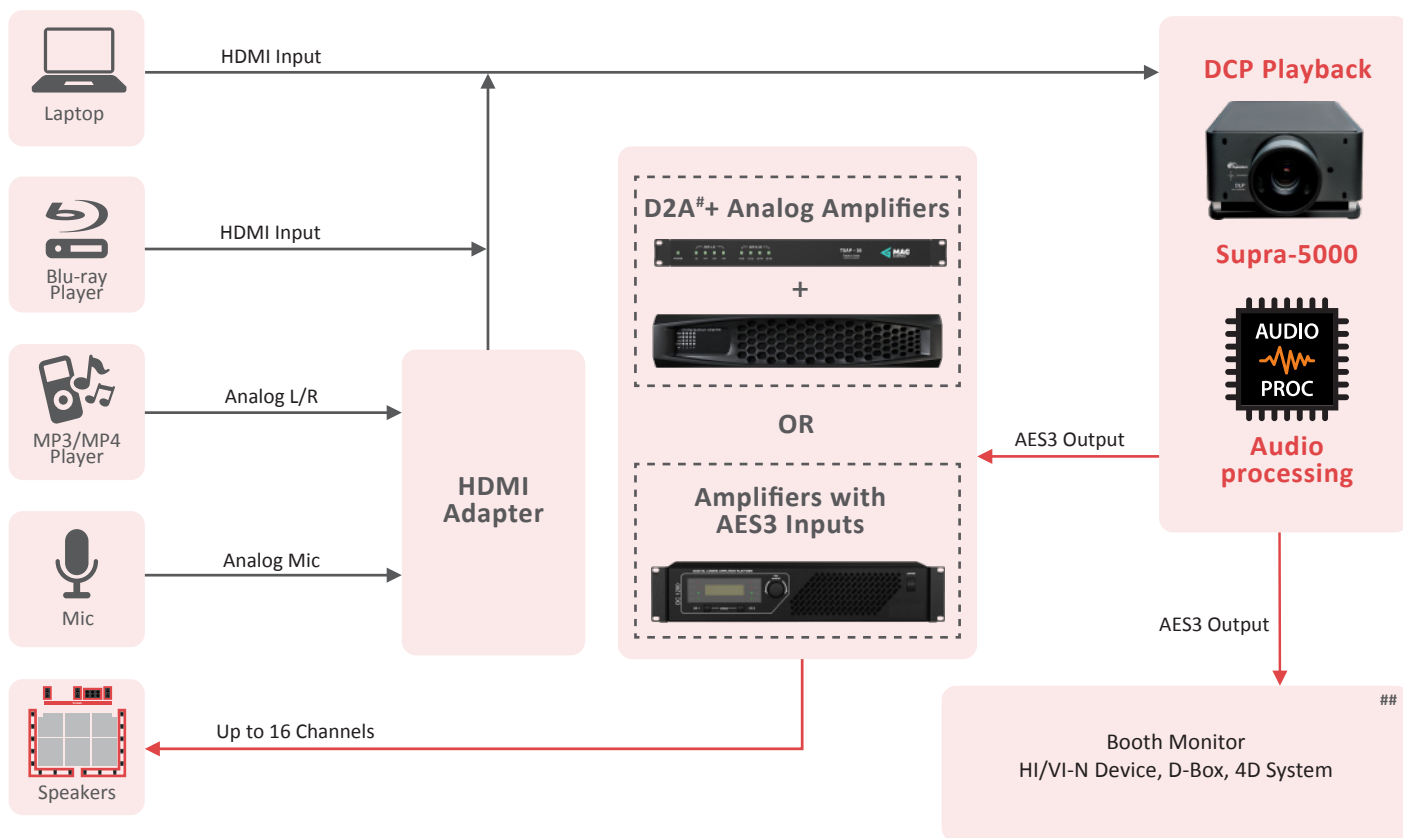

[#]Digital AES3 to Analog converter, up to 16 channels
^{##}Depends on the specific system configuration

Built-in Professional 5.1 / 7.1 Cinema Audio Processor with optional Audio IO Box to interface with external audio equipment

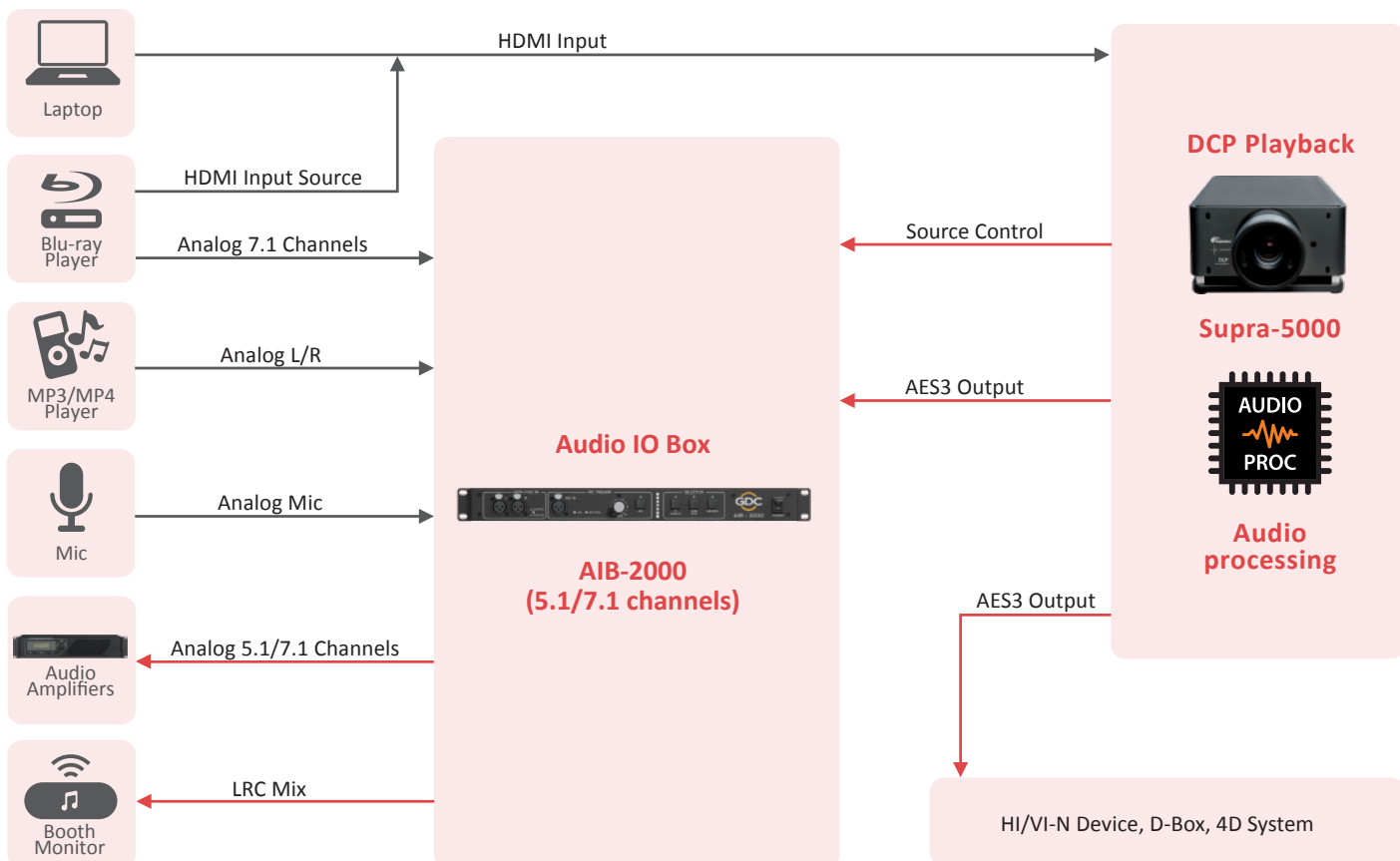

Powered by **ALPD 4.0 laser** and **DCI (studios) approved commercial cinema player**



Thanks to its sophisticated technical features, the Espedeo Supra opens up areas where professional projection had not been possible before.



The jury of Red Dot Design Award

reddot winner 2020

Build professional cinema “anywhere” you want

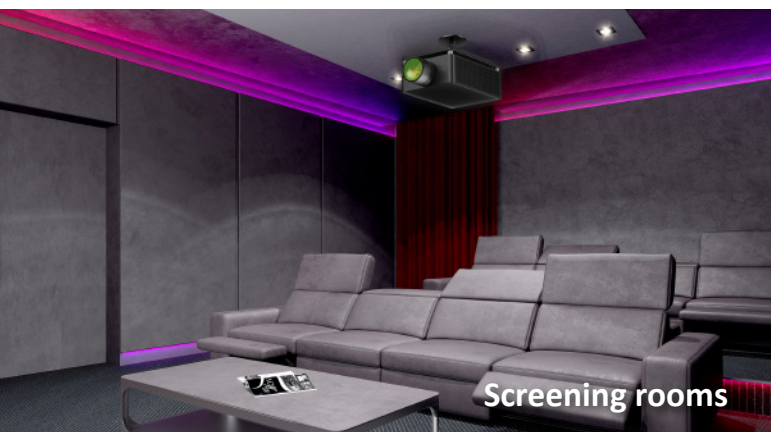

Screening rooms



Mini-theatres



Yachts



Private cinemas



Hotels

Espedeo Supra-5000 specifications

Light source type	ALPD 4.0 RGB+ laser phosphor technology
Motorized lens	1.58-2.49:1, 1.28-1.92:1, 0.8:1
Lens shift	V : ± 50% & H : ±25%
Resolution	2048 x 1080 pixels
Contrast ratio	2,000:1
Screen size	Up to 6m (20ft) wide (screen gain 1.0@20fL)
Color gamut	DCI-P3
Projector brightness	5,000 lumens
Laser lifetime	Up to 40,000 hours depending on mode of operation ¹
3D system option	Espedeo PM-2000B with unique polarized light technology, luminous efficiency reaches over 30% with customized single beam
Digital Micromirror Device (DMD)	0.49" TRP
Light engine protection level	IP5X
Noise level	≤ 35dB(A) (no hush box design)
Cooling	Air cooling without exhaust
Video input	HDMI 1.4 (2 x Type A receptacle)
System interfaces	1 x Wi-Fi - IEEE 802.11n 2 x Gigabit Ethernet (1GbE/RJ-45), 2 x Ethernet (100 Base-T) 2 x USB 3.0 (A-Type Female), 1 x USB 2.0 (A-Type Female) 8 x GPI (2 x RJ-45) 8 x GPO (2 x RJ-45) 1 x BNC (LTC-OUT) 1 x 3D Interface
Audio output	24-bit AES3, 16 channels, 48/96kHz (2 x RJ-45)
DCP playback	DCI-compliant JPEG 2000 frame rate (fps) 2D – 24, 25, 30, 48, 50, 60 3D – 24, 25, 30 SMPTE digital cinema package (DCP), Interop DCP
Video processing features	<ul style="list-style-type: none">• Color-space conversion – supports YCbCr709, REC 709, X'Y'Z', YCxCz• Deinterlacing• Scaler to support 2K
Security	<ul style="list-style-type: none">• NexGuard® forensic watermarking• FIPS 140-2 (Level 3 security certified)
Subtitles	Subtitle overlay
Closed captioning device	Support SMPTE430-10
Integrated storage	CineCache™ 2TB
External storage with options	<ul style="list-style-type: none">• Capable of direct connection to and designed for use with up to 204TB SCL Mk2 Series Centralized Playback Server• Network-attached storage (NAS)²
Supra Command Center	<ul style="list-style-type: none">• Integrated projector and media-player control• Screen setup and management• Cinema automation setup• Show scheduling with auto-playlist• Intuitive web-based user interface accessible via compatible web-browser on PC, MAC, Android or iOS devices
Dimensions (W x D x H)	480 x 803 x 275mm / 18.90 x 31.61 x 10.83in.
Maximum weight	47kg / 104.1lbs (with lens 1.28-1.92:1)
Power requirement	<ul style="list-style-type: none">• Type 1 rating: 200-240Vac 50/60Hz 4-3A (single phase) or 200-240Vac (2W + ⊕), 50/60Hz, 4-3A (dual live line)• Type 2 rating: 100-240Vac, 50/60Hz, 9-4A (single phase)
Power consumption	750W
Operating temperature	5°C to 35°C (41°F to 95°F)
Storage temperature	-10°C to 60°C (14°F to 140°F)
Operating humidity	10% to 85%RH (Max.)

¹ Laser light source: 40,000 hours (at 3,500 lumens setting with paid warranty)
60,000 hours (at 3,500 lumens setting with paid extended warranty)

² Please check with GDC on qualified NAS storage

Espedeo Supra-5000 Built-in Cinema Audio Processor (optional) specifications

Audio Source

DCP source	5.1/7.1 surround sound channels and up to 16-channel DTS:X immersive audio supporting IAB
HDMI input	8 channels PCM
Microphone input (via Audio IO Box or HDMI adapter [^])	Microphone level input with switchable +48V phantom power, adjustable gain and selectable HPF (via Audio IO Box [^])
Non-sync input (via Audio IO Box or HDMI adapter [^])	Stereo line level inputs
Analog balanced 7.1 input (via Audio IO Box [^])	8 channels analog line level inputs

Audio Output

Digital audio output	16 channels AES3, LCR Monitor, HI/VI-N, LTC (sync for 4D systems) and DBOX motion signal
Analog audio output (via Audio IO Box [^])	8/16 channel balanced analog line level outputs

Audio Processing

DSP Processing (5.1/7.1/15.1)	32 bits full floating point DSP processing
Graphic EQ for 7/15 channels (non-LFE channels)	1/3 octave graphic EQ (27 bands) Band gain: -6dB to 6dB in 0.1dB step
Bass/Treble for 7/15 channels (non-LFE channels)	Bass level: -6dB to 6dB in 0.1dB step Treble level: -12dB to 12dB in 0.1dB step Treble corner frequency: 1K/2K/3K/4KHz
LFE parametric EQ	Center frequency: 20Hz to 120Hz in 10Hz step Bandwidth (Q): 0.5 to 10 in 0.1 step Gain: -12~6dB in 0.1dB step
LFE low pass filter	Default / SMPTE
Crossover (for 5.1/7.1 only)	Mode: 2-way Filter type: Butterworth, Linkwitz-Riley Filter slope: -6, -12, -18, -24, -36, -48dB/octave
Global delay for all channels	-250~200ms
Audio delay for individual channel	0~500ms
Volume control (main fader) for all channels	-90dB~10dB (fader 0~10)
Mute (fade-in/out) duration configuration	0.2 to 5.0 second in 0.1 step
Channel gain for individual channel	-22dB~8dB in 0.1dB step
PCM channel assignment	Yes
Signal generator	100Hz, 1KHz, 10KHz, Pink Noise, sweep
Audio input level meter	16 channels
Backup and restore	Audio configuration presets (equalization (EQ), crossover, channel delay, global delay and gain)

Performance

Dynamic range (via Audio IO Box [^])	>105dB
--	--------

[^] Note: Audio IO Box is sold separately, please refer to AIB-2000 Audio IO Box brochure

Dimensions

Unit (mm)

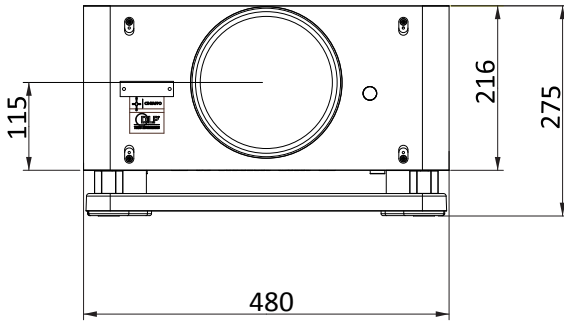

Front View

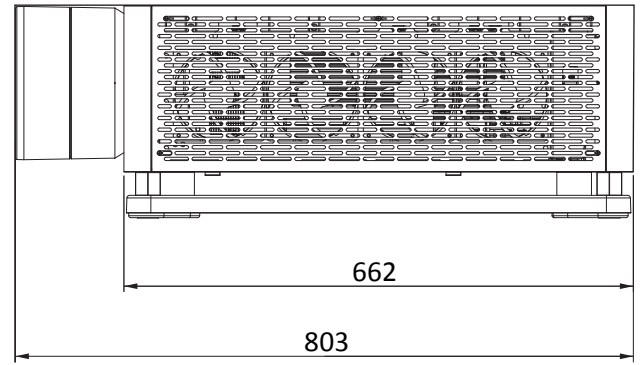

Side View

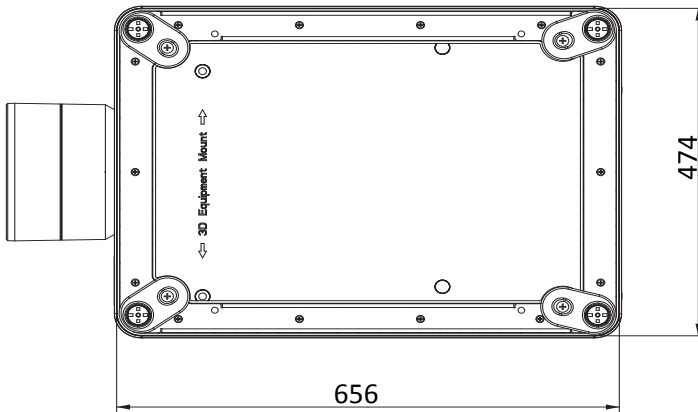

Top/Bottom View

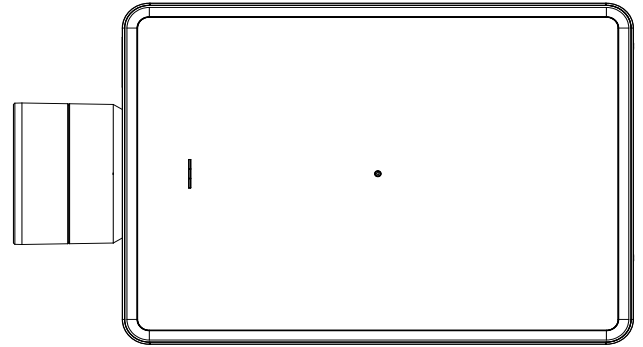

Technical support

Australia / New Zealand

Hotline: +61 407-040-744

Email: aus-support@espedeo.com

Europe

Email: eur-support@espedeo.com

India

Hotline: +91 022-4044-0500

Email: in-support@espedeo.com

Japan

Hotline: +81 3-5524-3607

Email: na-support@espedeo.com

Korea

Hotline: +82 70-8848-8890

Email: na-support@espedeo.com

Latin America

Hotline: +52 55-8851-1198

Email: latam-support@espedeo.com

North America

Hotline: +1 877-743-2872 (US Toll Free)

Email: us-support@espedeo.com

Southeast Asia

Hotline: +65 6100-4328

Email: sg-support@espedeo.com