

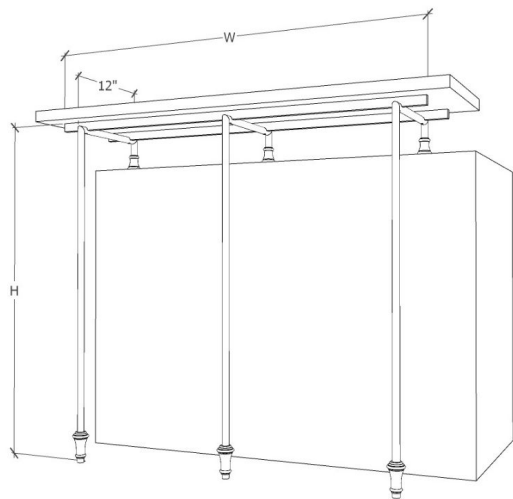

# FITTINGS

METAL COLLECTION



We recommend professional installation with all of our products to ensure that all the attachments and blocking considerations are met. Weight limitations and number of fasteners should be considered by the final user and professional installer.

## RAISED COUNTER SUPPORT

- A.** Choose desired location for application and mark drilling points on countertop material.

- B.** Secure mounting collars to surface by drilling holes through the countertop material and using the supplied mounting hardware.

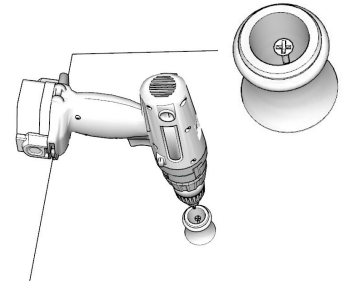

- C.** Place leg into mounting collar. Rotate at leg base to adjust foot for out of level conditions.

- D.** Once the foot is adjusted, finish leveling the horizontal support in the mounting collar and lock into place with the set screw.

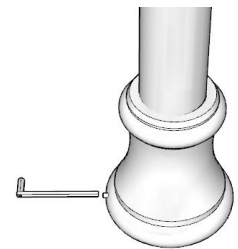
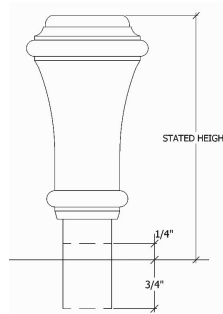

- E.** Attach long horizontal supports to legs below with supplied hardware.

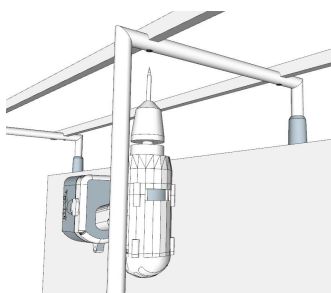

- F.** \*Optional: For additional support-foot can be secured to floor. Screw nylon bushing into desired location on floor.

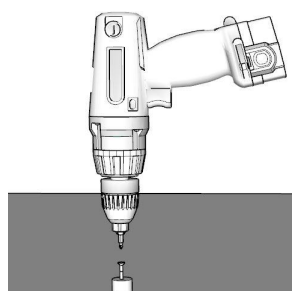

- G.** \*Optional: Foot sleeve fits over nylon bushing to secure to floor.

