

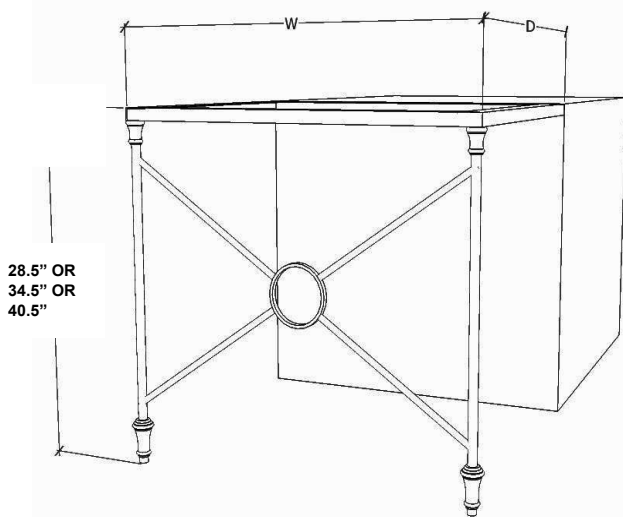

FITTINGS

METAL COLLECTION

TABLE EXTENSION



We recommend professional installation with all of our products to ensure that all the attachments and blocking considerations are met. Weight limitations and number of fasteners should be considered by the final user and professional installer. Installers are responsible for any anti-tip fasteners or devices. Certain products are not recommended for free-standing pieces.

- A.** Locate suitable blocking and position table extension in desired location.

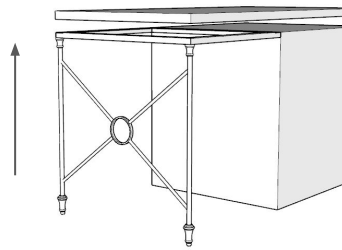

- B.** Secure by drilling through the metal back frame making sure the blocking is met at several points.

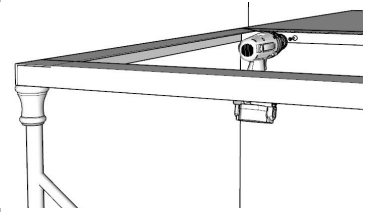

- C.** Adjust by rotating the lower portion of the foot. Size ranging $\frac{1}{4}$ " shorter and $\frac{3}{4}$ " longer than stated size.

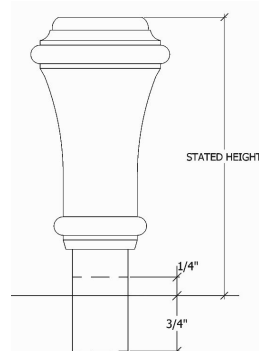

- D.** Optional: For additional support-foot can be secured to floor. Screw nylon bushing into desired location on floor.

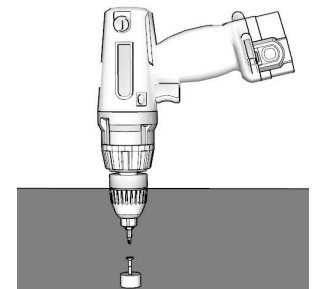

- E.** Optional: Foot sleeve fits over nylon bushing to secure to floor.

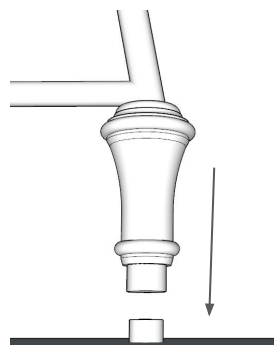

- F.** Once table extension is secured properly, top with your desired countertop.

