

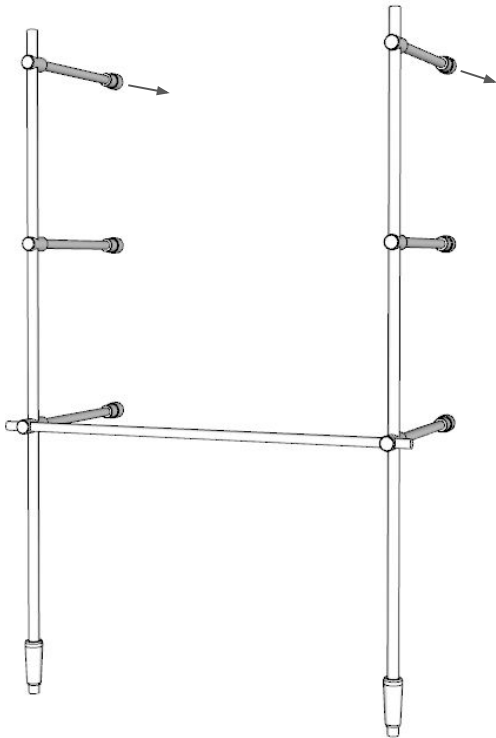

FITTINGS

BISTRO FLOOR/COUNTER TO WALL SHELF NO REAR VERTICAL

METAL COLLECTION



We recommend professional installation with all of our products to ensure that all the attachments and blocking considerations are met. Weight limitations and number of fasteners should be considered by the final user and professional installer.

- A.** Measure the spacing for your vertical supports and mark the wall with your center points. We recommend leaving minimum 1.5" overhang from vertical support centerline for glass overhang.

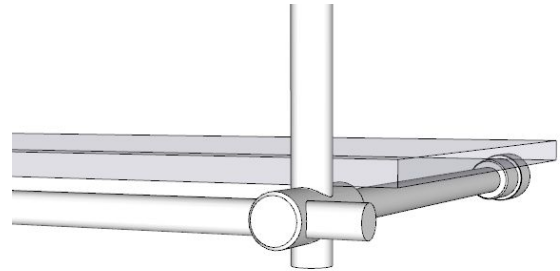

- B.** Mount collars to surface blocking or ceiling blocking and affix by screwing into place.

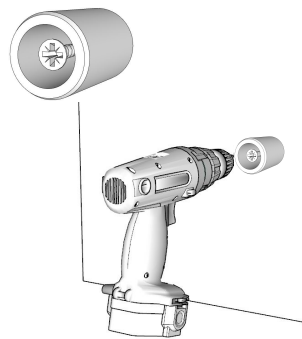

- C.** Make sure all set screws for vertical rods are backed out of each hole for easy assembly. Slide short horizontal rods onto vertical rods and tighten once in desired position.

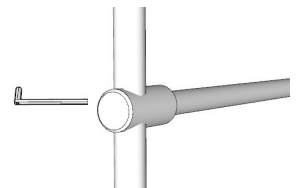

- D.** Slide rods into each mounting collar. Tighten set screw against the wall mounted fitting to secure vertical assemblies into place.

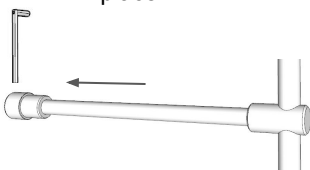

- E.** Place adjustable foot under vertical rod and rotate at the base to adjust the height. Size ranging from $\frac{1}{4}$ " shorter and $\frac{3}{4}$ " longer than stated size.

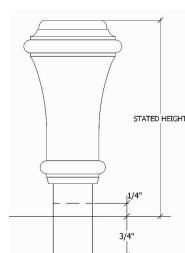

- F.** Insert the horizontal rod into the bottom fitting and secure with set screw. Place desired shelving onto brackets.

