



# FITTINGS

METAL COLLECTION

ABRUZZO COLLECTION



We recommend professional installation with all of our products to ensure that all the attachments and blocking requirements are met. Weight limitations and number of fasteners should be considered by the final user and professional installer. Product was tested to support 100 pounds with proper blocking. Installers are responsible for any anti-tip fasteners or devices. Certain products are not recommended for free-standing pieces.



# FITTINGS

ABRUZZO COLLECTION

METAL COLLECTION

## TOOLS REQUIRED:

- PHILLIPS-HEAD SCREWDRIVER or ELECTRIC SCREWDRIVER
- HEX KEY / ALLEN KEY WRENCH (INCLUDED IN HARDWARE PACKET)
- LASER LEVEL

\*WE RECOMMEND HAVING A SECOND PERSON FOR ASSEMBLY.

**NOTE: ALL CONNECTIONS TO WALL OR CEILING MUST HAVE BLOCKING AND / OR STUDS TO PROVIDE PROPER SUPPORT FOR WINE WALL ASSEMBLY UNIT.**

We recommend professional installation with all of our products to ensure that all the attachments and blocking requirements are met. Weight limitations and number of fasteners should be considered by the final user and professional installer. Product was tested to support 100 pounds with proper blocking. Installers are responsible for any anti-tip fasteners or devices. Certain products are not recommended for free-standing pieces.



# FITTINGS

## ABRUZZO COLLECTION

METAL COLLECTION

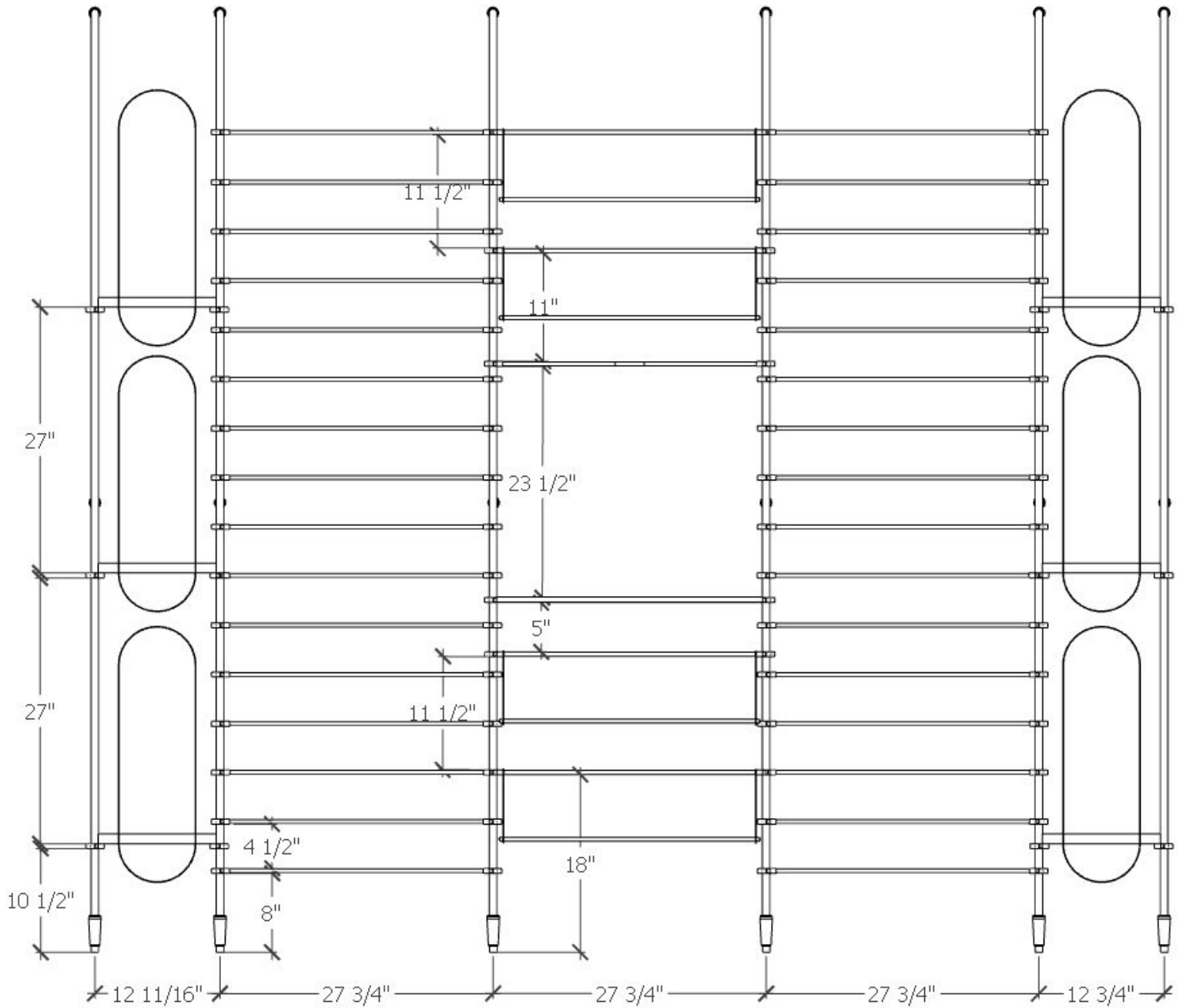



# FITTINGS

## ABRUZZO COLLECTION

### METAL COLLECTION

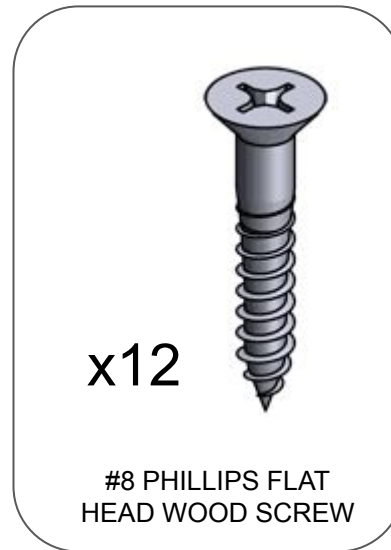
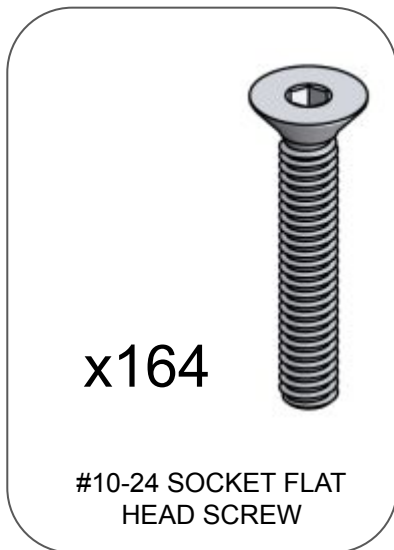
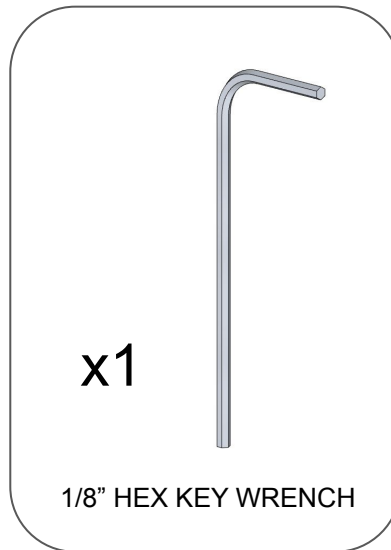
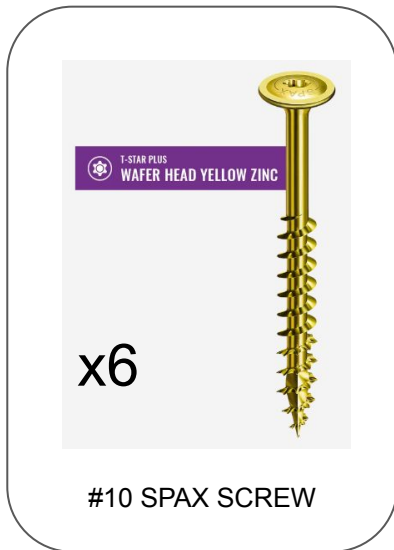



# FITTINGS

## ABRUZZO COLLECTION

### METAL COLLECTION

**A**

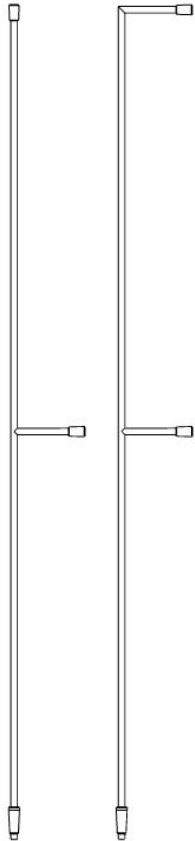

**x6**

MONO BRACKET

**B**

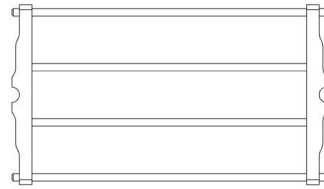

**x32**

LABEL OUT WINE RACK

**L**

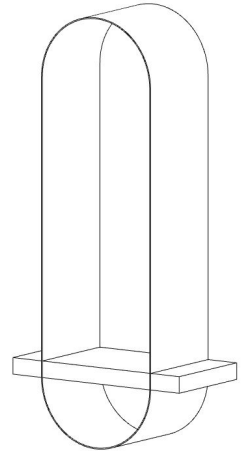

**x6**

12" CAPSULE

**C**

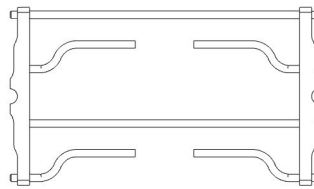

**x1**

LINEAR STEMWARE

**H.45**

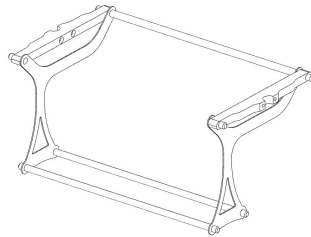

**x4**

45° ANGLED WINE DISPLAY

**M**

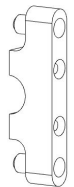

**x12**

SINGLE END PLATE

**K**

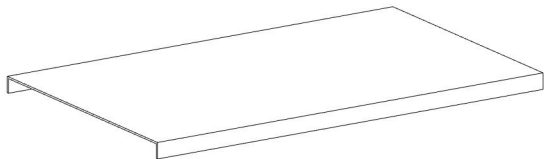

**x1**

METAL SHELF

**O**

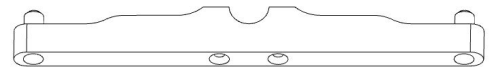

**x2**

DOUBLE END PLATE

**N**

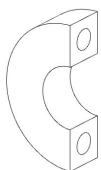

**x76**

END PLATE CONNECTOR

NOTE: 'PART B' AND 'PART C' MAY VARY SLIGHTLY DEPENDING ON THE ACTUAL UNIT BOTTLE DEPTH PURCHASED.



# FITTINGS

## ABRUZZO COLLECTION

METAL COLLECTION

### WALL MOUNTED BRACKET INSTALLATION

- 1.** MOUNT COLLARS FROM 'PART A' TO SURFACE BLOCKING BY SCREWING INTO PLACE WITH #10 SPAX SCREW. **BE SURE SET SCREW IS NOT IN A VISIBLE LOCATION.**

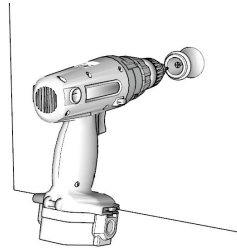

- 2.** LINE UP CENTER OF COLLAR WITH NYLON BUSHING OUT  $4 \frac{1}{2}$ " (SINGLE) OR  $8 \frac{1}{8}$ " (DOUBLE OR TRIPLE) FROM WALL. AFFIX THE BUSHING TO THE FLOOR WITH POCKET SCREW.

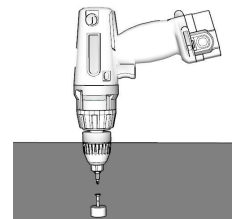
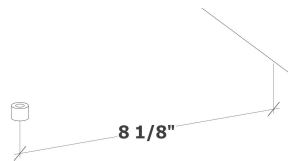

- 3.** ROTATE THE FOOT (PART A) AT THE BASE TO MAKE THE ADJUSTMENT  $\frac{1}{4}$ " SHORTER. SLIDE ONTO BUSHING.

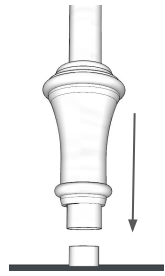
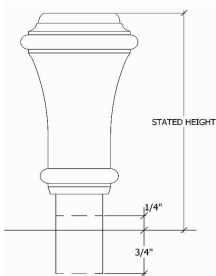

- 4.** SLIDE BRACKET (PART A) INTO MOUNTING COLLAR. TIGHTEN SET SCREW AGAINST THE BRACKET TO SECURE INTO PLACE.

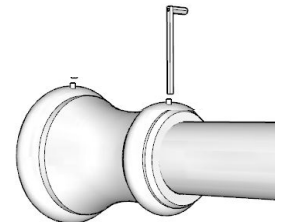
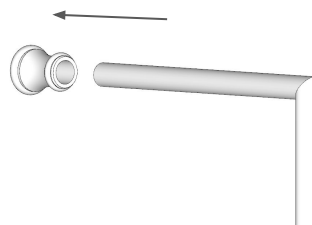

- 5.** ROTATE THE ADJUSTABLE FOOT AT THE BASE TO CREATE A SNUG FIT ON THE BRACKET. TOLERANCE  $\frac{1}{4}$ " SHORTER AND  $\frac{3}{4}$ " LONGER THAN STATED SIZE.

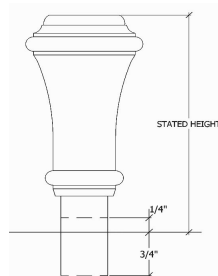

- 6.** REPEAT STEPS 1-5 FOR ALL (4) BRACKETS.

LAYOUT EACH SHELF ASSEMBLY ON THE FLOOR PRIOR TO ASSEMBLY. SET YOUR LASER LEVEL AT THE DESIRED HEIGHT STARTING WITH THE TOP LEFT SHELF.



# FITTINGS

## ABRUZZO COLLECTION

METAL COLLECTION

### CEILING MOUNTED BRACKET INSTALLATION

1. MOUNT COLLARS (PART A) TO CEILING BLOCKING BY SCREWING INTO PLACE WITH #10 SPAX SCREW. **BE SURE SET SCREW IS NOT IN A VISIBLE LOCATION.**

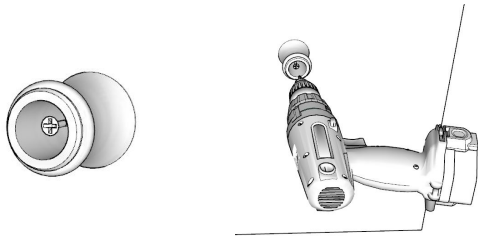

2. LINE UP CEILING COLLAR WITH NYLON BUSHING. AFFIX THE BUSHING TO THE FLOOR.

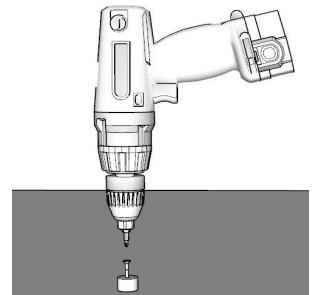

3. SLIDE BRACKET (PART A) INTO MOUNTING COLLAR. **DO NOT TIGHTEN SET SCREW AT THIS TIME!**

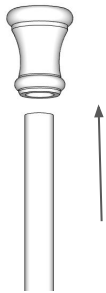

4. ROTATE THE FOOT AT THE BASE TO MAKE THE ADJUSTMENT  $\frac{1}{4}$ " SHORTER. SLIDE ONTO 'PART A'.

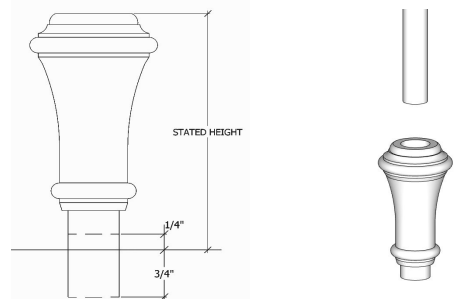

5. TIGHTEN THE SET SCREW ON THE MOUNTING COLLAR. EXTEND FOOT ADJUSTMENT OVER THE BUSHING UNTIL SNUG WITH FLOOR.

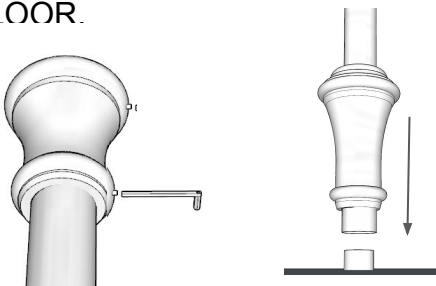

6. REPEAT STEPS 1-5 FOR ALL (4) BRACKETS.

LAYOUT EACH SHELF ASSEMBLY ON THE FLOOR PRIOR TO ASSEMBLY. SET YOUR LASER LEVEL AT THE DESIRED HEIGHT STARTING WITH THE TOP LEFT SHELF.



# FITTINGS

## ABRUZZO COLLECTION

### METAL COLLECTION

- 7.** SET UP THE LASER LEVEL TO YOUR DESIRED HEIGHT, STARTING AT TOP LEFT SIDE TO SET FIRST 12" CAPSULE (PART L). REMOVE SCREWS FROM 'PART N' AND SET ASIDE.

- 8.** PLACE 'PART N' ONTO 'PART A' AT DESIRED HEIGHT. PLACE 'PART N' ON EITHER SIDE OF 'PART A' AND USE SCREWS TO ATTACH.

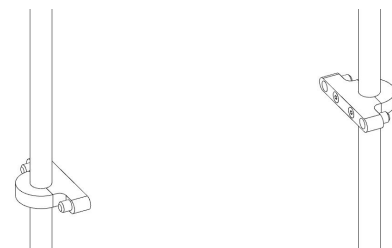

- 9.** PLACE 'PART L' ON TOP OF 'PART M'. MARK HOLE LOCATIONS AND DRILL PILOT HOLES. SECURE WITH (2) WOOD SCREWS (PROVIDED IN HARDWARE KIT).

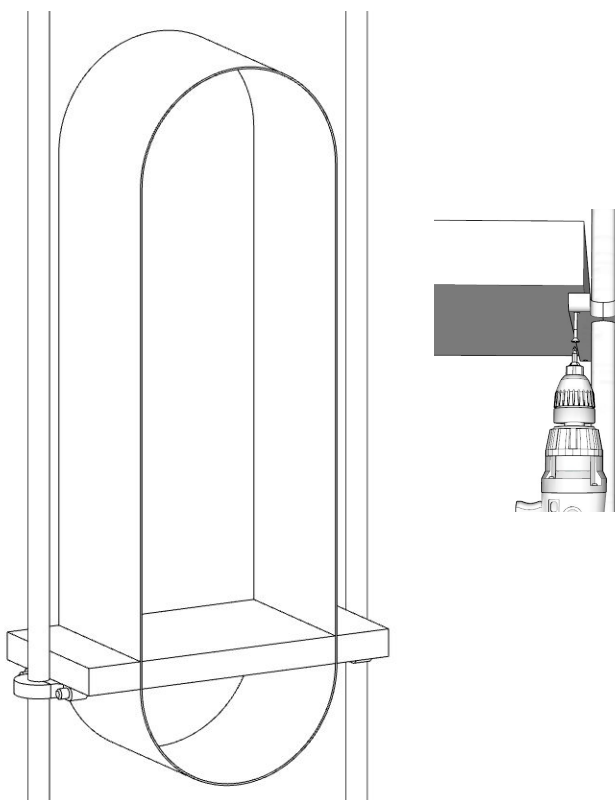

- 10.** REPEAT STEPS 8-7 FOR ALL (6) 12" CAPSULES (PART L).

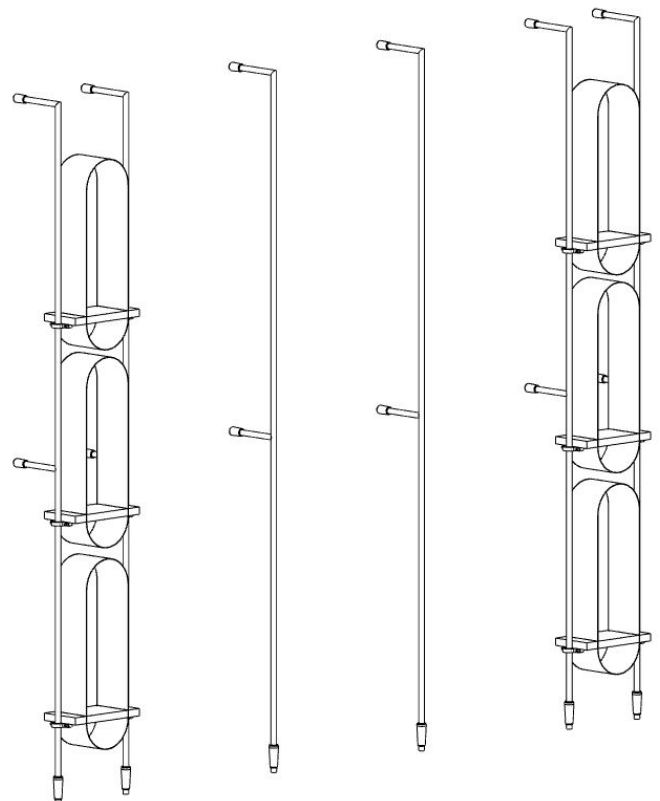





# FITTINGS

METAL COLLECTION

ABRUZZO COLLECTION

- 11.** SET UP THE LASER LEVEL TO YOUR DESIRED HEIGHT, STARTING AT THE TOP FOR THE CENTER SECTION TO SET THE FIRST LABEL OUT WINE RACK (PART B). REMOVE SCREWS FROM 'PART N' AND SET ASIDE.

- 12.** PLACE 'PART B' ONTO 'PART A' AT DESIRED HEIGHT. PLACE 'PART 'N' ON EITHER SIDE OF 'PART A' AND USE SCREWS TO ATTACH.

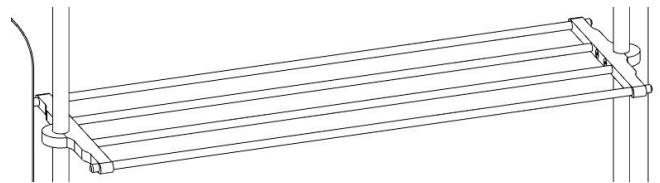

- 13.** REPEAT STEPS 11-12 FOR ALL (32) LABEL OUT WINE RACKS (PART B).

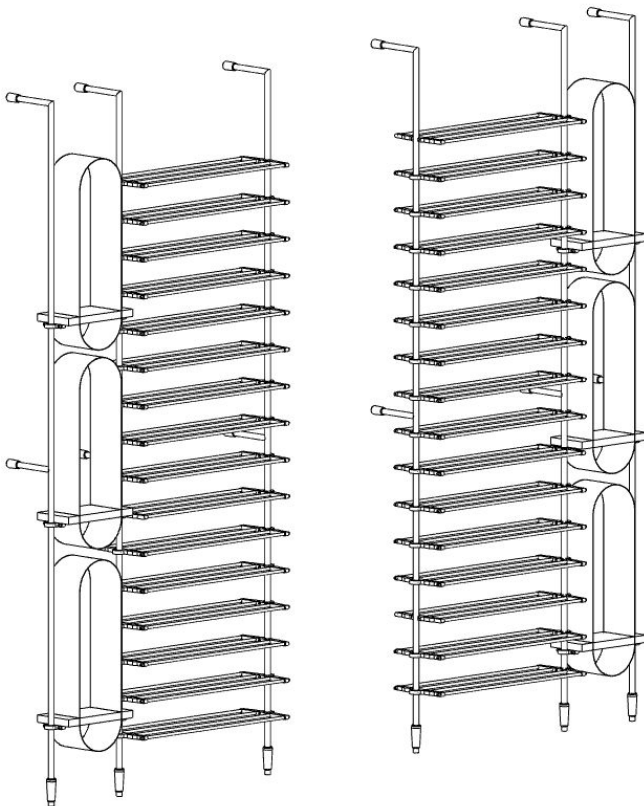



# FITTINGS

METAL COLLECTION

ABRUZZO COLLECTION

- 14.** SET UP THE LASER LEVEL TO YOUR DESIRED HEIGHT FOR THE LINEAR STEMWARE (PART C). REMOVE SCREWS FROM 'PART M' AND SET ASIDE.

- 15.** PLACE 'PART C' ONTO 'PART A' AT DESIRED HEIGHT. PLACE 'PART N' ON EITHER SIDE OF 'PART A' AND USE SCREWS TO ATTACH.

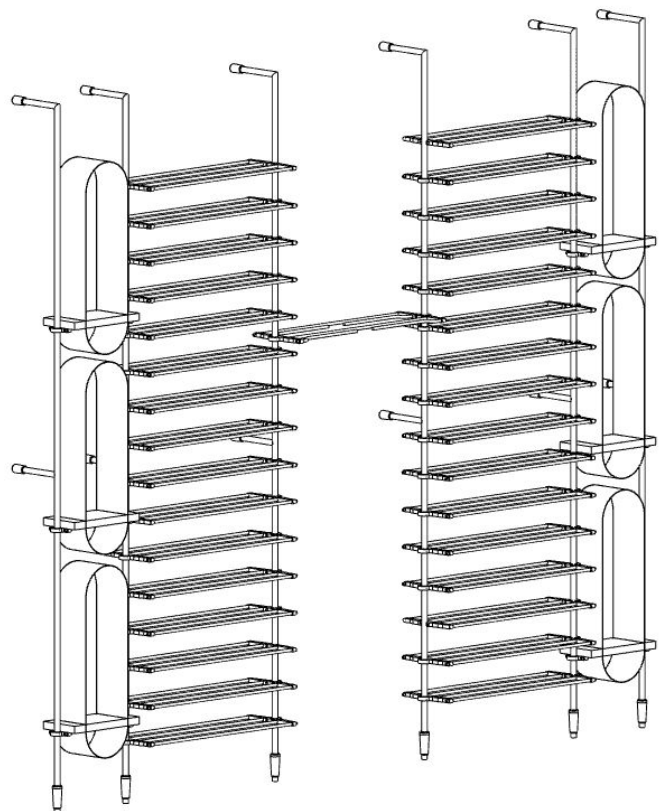



# FITTINGS

METAL COLLECTION

ABRUZZO COLLECTION

- 16.** SET UP THE LASER LEVEL TO YOUR DESIRED HEIGHT FOR THE METAL SHELF (PART K). REMOVE SCREWS FROM 'PART N' AND SET ASIDE.

- 17.** PLACE 'PART O' ONTO 'PART A' AT DESIRED HEIGHT. PLACE 'PART N' ON EITHER SIDE OF 'PART A' AND USE SCREWS TO ATTACH.



- 18.** PLACE 'PART K' ONTO 'PART O' AND PRESS INTO PLACE. METAL SHELF WILL FIT SNUG AROUND END PLATES.

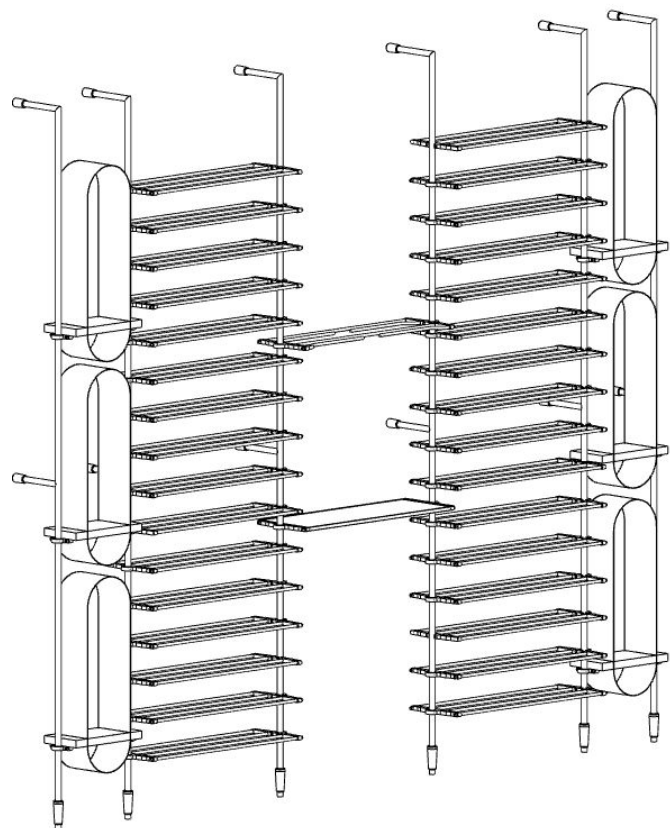
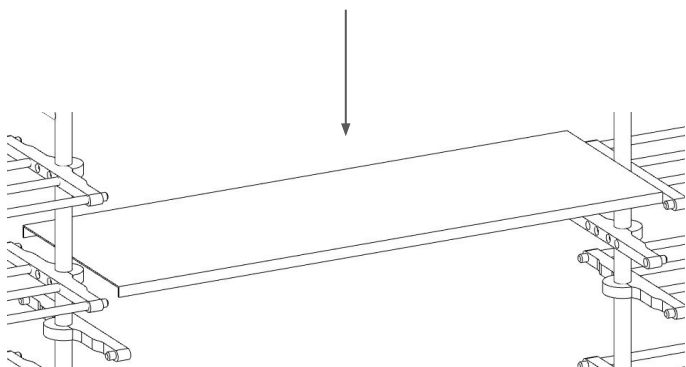



# FITTINGS

METAL COLLECTION

ABRUZZO COLLECTION

- 19.** SET UP THE LASER LEVEL TO YOUR DESIRED HEIGHT FOR THE FIRST ANGLED WINE DISPLAY (PART H.45). REMOVE SCREWS FROM 'PART N' AND SET ASIDE.

- 20.** PLACE 'PART H.45' ONTO 'PART A' AT DESIRED HEIGHT. PLACE 'PART N' ON EITHER SIDE OF 'PART A' AND USE SCREWS TO ATTACH.

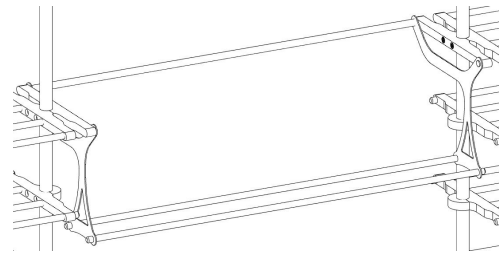

- 21.** REPEAT STEPS 19-20 FOR ALL (4) ANGLED WINE DISPLAY (PART H.45).

