

**ICELED<sup>®</sup>**  
***DIGITAL LIGHTING***  
**FLEXIDRIVER+** INSTALLATION  
& USER GUIDE

## Features

ICELED **FLEXIDRIVER+** integrates a multi-function lighting controller with three channels of proportional power delivery for common RGB lighting loads such as flexible LED tape. Control modes include:

- Independent Hue, Saturation and Brightness adjustment
- Smooth colour scroll with adjustable speed
- Sound reactive Hue/Brightness with adjustable response
- Automatic fade up/down with adjustable Brightness for power saving
- Two Program stores for instant recall of all mode settings

**FLEXIDRIVER+** also provides a standard ICELED digital lighting data Input/Output for optional integration with other ICELED light sources, controllers and drivers. Simple Master/Slave functionality provides local/remote control of the RGB outputs when "data connected" to other ICELED products.

## Wiring

Connections are made via screw-terminals on the outside of the casing.

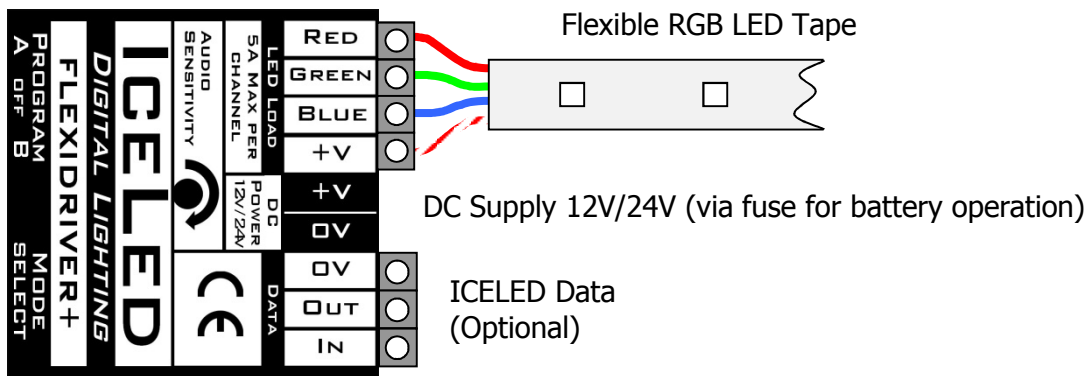

## Operation

The **PROGRAM** switch has three positions. In the centre-off position, **FLEXIDRIVER+** remains in low-power **standby** state with all connected LED's turned off.

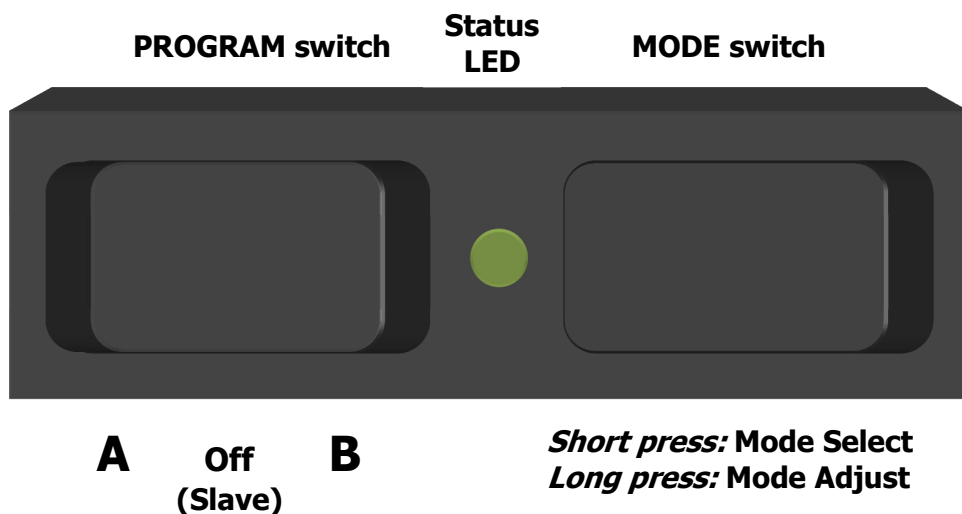

When in standby, if ICELED data is present at the **Data In** terminal, **FLEXIDRIVER+** becomes a **Slave** to the controller producing the data – behaving like a standard **FLEXIDRIVER** under ICELED control. Such a controller could be another **FLEXIDRIVER+** or a different type of ICELED controller e.g. ZEN or ZAP.

### Program A – B selection

In either of the two active switch positions (**A** or **B**) the internally stored Program settings determine the way the LEDs are lit. In this case **FLEXIDRIVER+** also becomes a **Master** to any ICELED devices connected to the **Data Out** terminal.

When Programs **A** or **B** are active, the **MODE** switch can be used to select the desired Program Mode by *briefly* clicking the switch to cycle through each of the five available modes:

1. **Brightness**
2. **Saturation** (whiteness)
3. **Hue** (colour)
4. **Colour scroll**
5. **Sound to Light**

Each Mode shows a unique “flash pattern” on the status LED to identify it from all the other Modes. The Mode and any subsequent adjustments made to the Mode are automatically stored for the active Program (**A** or **B**).

To adjust the relevant setting for a given Mode, the **MODE** switch must be pressed and *held* for sufficient time to arrive at the desired setting. For example, when in Brightness Mode, the Brightness will alternately decrease or increase for each long press of the switch.

The status LED and output of **FLEXIDRIVER+** will flash rapidly when the limits of any particular setting have been reached.

### MODE switch action summary

Mode ( <i>short press</i> )	Mode adjustment ( <i>long press</i> )	Status LED appearance
<b>Brightness</b>	Cycles between 10% to 100%	Steady
<b>Saturation</b>	Cycles between 10% to 100%	Single bright flash
<b>Hue</b>	Cycles through all hues	Multiple bright flashes
<b>Colour Scroll</b>	Scroll speed	Pulsating up and down
<b>Sound to Light</b>	Fade-down level	Blinks in time with sound

Both **Colour Scroll** and **Sound to Light** Modes make use of the Program **Saturation** setting to further enhance the range of effects that can be obtained.

### Automatic dimmer

**FLEXIDRIVER+** constantly monitors the sound level in the local environment, judging whether the surrounding space requires the full level of lighting or not. After five minutes of unbroken silence, if either Program (**A** or **B**) is active, the lighting level is gently reduced to a pre-set level in order to manage power consumption.

The pre-set dimmer level can be adjusted from 0 to 100%:

- ▶ At the minimum setting **FLEXIDRIVER+** becomes a sound-activated “on/off switch” automatically turning on the lighting when sufficient sound levels are detected and off again when it becomes sufficiently quiet.
- ▶ Intermediate dimmer settings can be used to provide low-power ambient illumination for unoccupied or quiet spaces.
- ▶ At the maximum setting the automatic dimmer is effectively disabled.

**To adjust the pre-set dimmer level**, set the **PROGRAM** switch to the centre-off position and hold the **MODE** switch in order to cycle to the desired lighting level (the last active program settings used will be previewed to aid with this adjustment).

**Audio sensitivity** can be adjusted by turning the recessed dial in the centre of the unit using a small flat-bladed screwdriver (not supplied). Clockwise rotation increases sensitivity.



## Factory reset

All **FLEXIDRIVER+** settings can be restored to their factory defaults by applying the power supply while the **MODE** switch is pressed and held in. During this process the status LED flashes for a couple of seconds. The switch can then be released once the LED stops flashing and all settings will be restored to their defaults.

## Specifications

Nominal supply voltage:	12~24 Volts DC (Via 2.1mm DC Jack, centre +Ve)
Maximum switched current:	5 Amps (per channel)
Maximum “through” current:	15 Amps
Data accepted:	Global ICELED, UFO tube segment 0, pixel 0
Dimensions:	W 50mm H 50mm D 15mm
Conformity:	EMC Directive (2004/108/EEC)



## Resources

To see the full ICELED product range visit <http://www.iceled.co.uk> the official ICELED website.

For more suggestions and advice visit <http://iceled.co.uk/area51/> the official ICELED user forums.