

SM330M (BF)

RESIDENTIAL LINE



MADE IN ITALY MODULE

Peimar monocrystalline solar panels, produced using a combination of innovative production processes and advanced engineering techniques, provide customers with maximum output and super high performance.

This allows fewer panels to be used to generate more energy, ideal if space is restricted or environmental conditions are challenging. Modern design, using matching black cells and frames and a very long lifespan ensure this monocrystalline are a great option.



30 YEAR LINEAR POWER WARRANTY

20 YEAR PRODUCT WARRANTY



PERC TECHNOLOGY



MODULE FIRE PERFORMANCE: **CLASS 1**



ANTI-REFLECTIVE GLASS



QBE INSURANCE
Product Liability Insurance QBE

CELLS

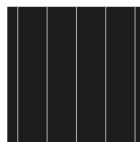

60 CELLS
MONO 5BB M3 | **PERC**

158.75x158.75mm / 6.25x6.25"

FRAME



COMPACT AND STURDY | **40mm**

ANCHORABLE ALSO ON THE SHORT SIDE ⁽⁴⁾

ELECTRICAL CHARACTERISTICS (STC) ⁽¹⁾

Nominal Output (Pmax)	
Power Tolerance	
Voltage at Pmax (Vmp)	
Current at Pmax (Imp)	
Open Circuit Voltage (Voc)	
Short Circuit Current (Isc)	
Maximum System Voltage	
Maximum Series Fuse Rating	
Module Efficiency	
Protection class against electric shock	

SM330M (BF)	
Nominal Output (Pmax)	330 W
Power Tolerance	0/+5 W
Voltage at Pmax (Vmp)	34.35 V
Current at Pmax (Imp)	9.61 A
Open Circuit Voltage (Voc)	41.91 V
Short Circuit Current (Isc)	10.18 A
Maximum System Voltage	1500 V
Maximum Series Fuse Rating	20 A
Module Efficiency	19.78%
Protection class against electric shock	Class II

MECHANICAL CHARACTERISTICS

Solar Cells	60 (6x10) M3 monocrystalline PERC
Solar Cells Size	158.75x158.75 mm / 6.25x6.25"
Front Cover	3.2 mm / 0.13" thick, low iron tempered glass
Back Cover	TPT (Tedlar-PET-Tedlar)
Encapsulant	EVA (Ethylene vinyl acetate)
Frame	Anodized aluminium alloy, double wall
Frame finishing	Black
Backsheet finishing	White
Diodes	3 Bypass diodes serviceable
Junction Box	IP67 rated
Connector	MC4 or compatible connector
Cables Length	900 mm / 35.43"
Cables Section	4.0 mm ² / 0,006 in ²
Dimensions	1665x1002x40 mm / 65.55x39.45x1.57"
Weight	18.6 Kg / 41.01 lbs
Max. Load ⁽⁴⁾	Certified to 5400 Pa

TEMPERATURE CHARACTERISTICS

NOCT ⁽²⁾	45±2 °C
Temperature Coefficient of Pmax	-0.37 %/°C
Temperature Coefficient of Voc	-0.28 %/°C
Temperature Coefficient of Isc	0.042 %/°C
Operating Temperature	-40 °C ~ +85°C

PACKAGING ⁽³⁾

Pallet dimensions	1720x1200x1210 mm / 67.72x47.24x47.64"
Pieces per pallet	27
Weight	535 Kg / 1179 lbs

CERTIFICATIONS

Fire Resistance Rating	Class of reaction to fire: 1 (UNI 9177)
Fire Performance Rating	Type 1 (UL 1703-3rd Edition)

DIMENSIONS

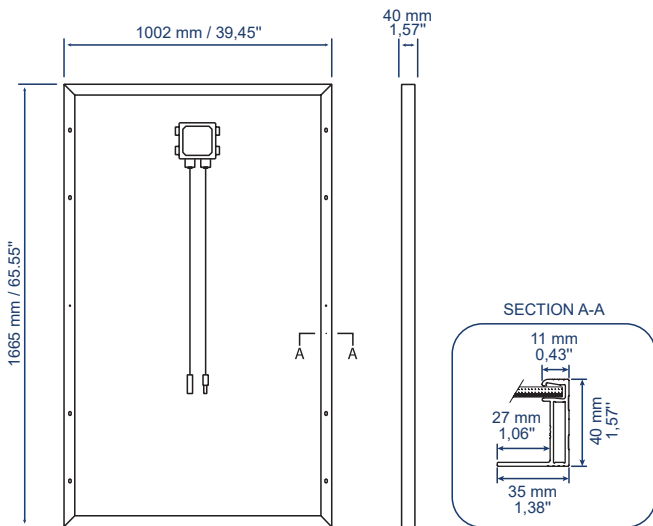

CURRENT/VOLTAGE CHARACTERISTICS

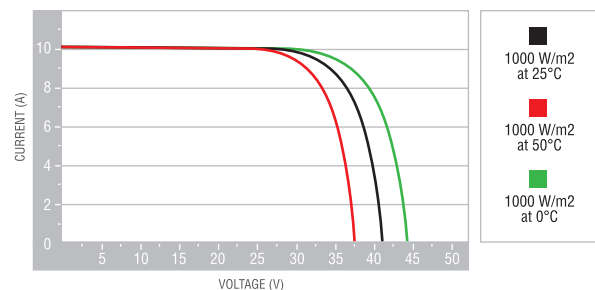
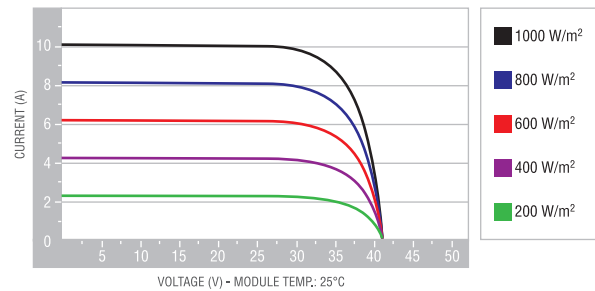

1. STC: (Standard Test Condition) Irradiance 1000W/m²; Module Temperature 25°C; Air Mass 1.5

2. NOCT: (Nominal Operation Cell Temperature) Irradiance 800W/m²; Air 20°C; Wind speed 1m/s

3. Pallets can be stacked up to two

4. Consult the installation manual for the relative mounting configurations