

Installation Manual

Steel Ground Mounting Structure

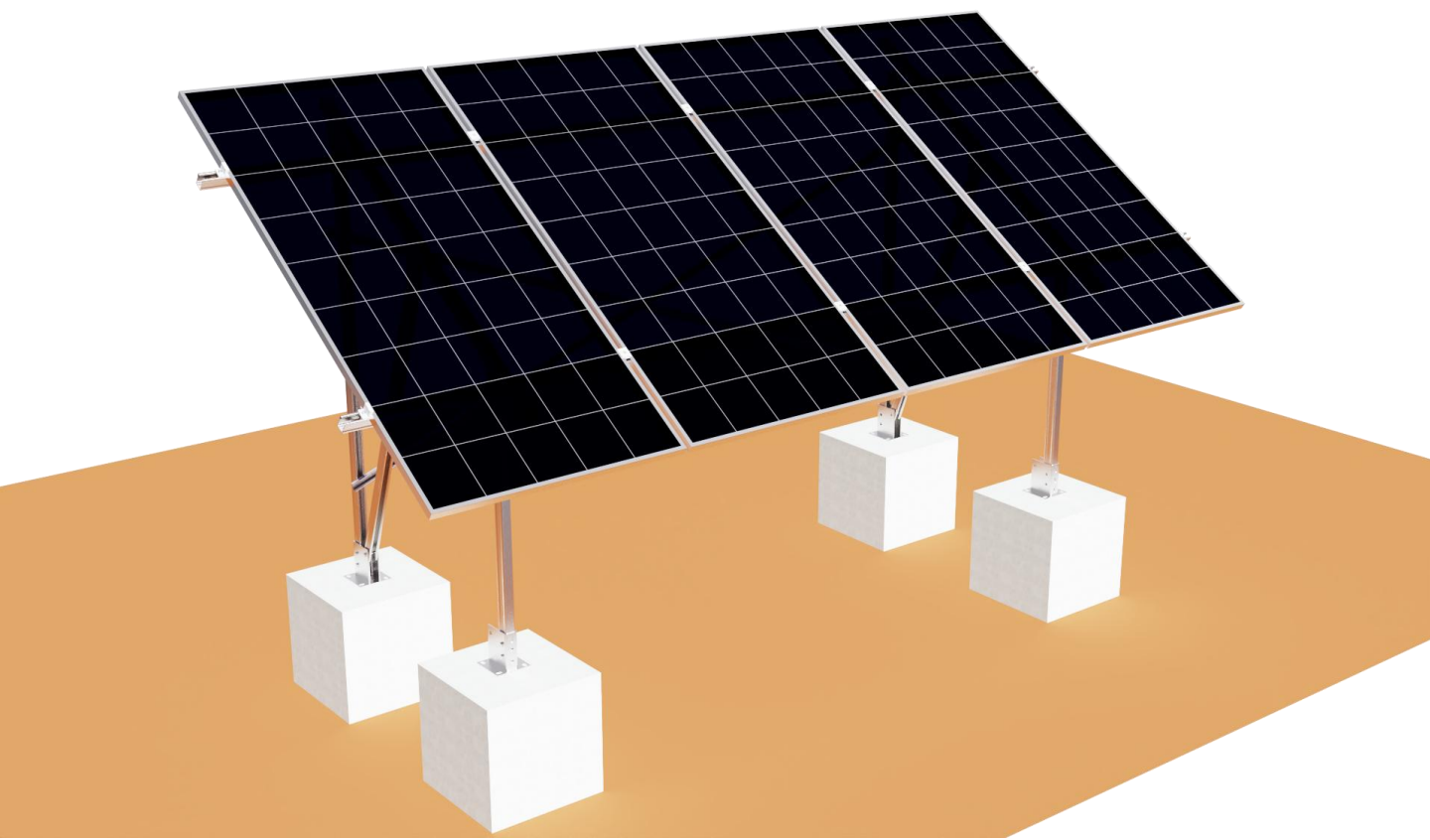

Steel Ground Mounting Structure

www.volts.ca

Components List:

Base



Front Leg



Rear Leg



Splice

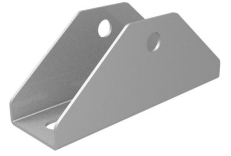

rail connector



Cable-stayed



Beam



Rail



End Clamp

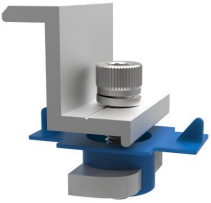

Inter Clamp

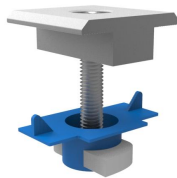

Bolt-1



Bolt-2



Bolt-3



Expansion
Anchor bolt



Diagonal Strut



Bolt-4



Installation Steps :

Step1. Preparatory work: Make the concrete foundation(cube or circle shape are both ok.)

A: For circle shape: the dimension is $\phi 400 \times H500 \text{mm}$

B: For cube shape: the dimension is $500 \times 500 \times 500 \text{mm}$

The distance of concrete foundation is 3000mm and 1100mm like the picture as below.

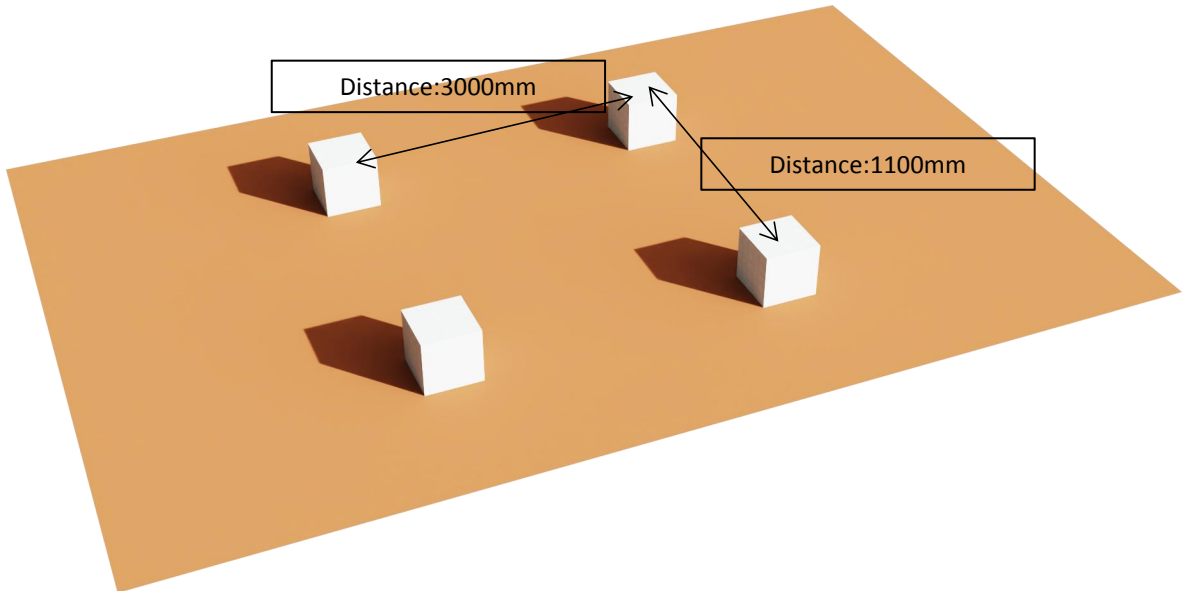

Step2. Install the front and rear leg to the base with M12x25mm and M12x80mm bolts.

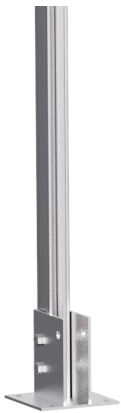

Bolt-2: M12x80mm

Bolt-1: M12x25mm



Step3. Install the splices to the beam with M12x25 bolt and M12x80 bolt like the picture.

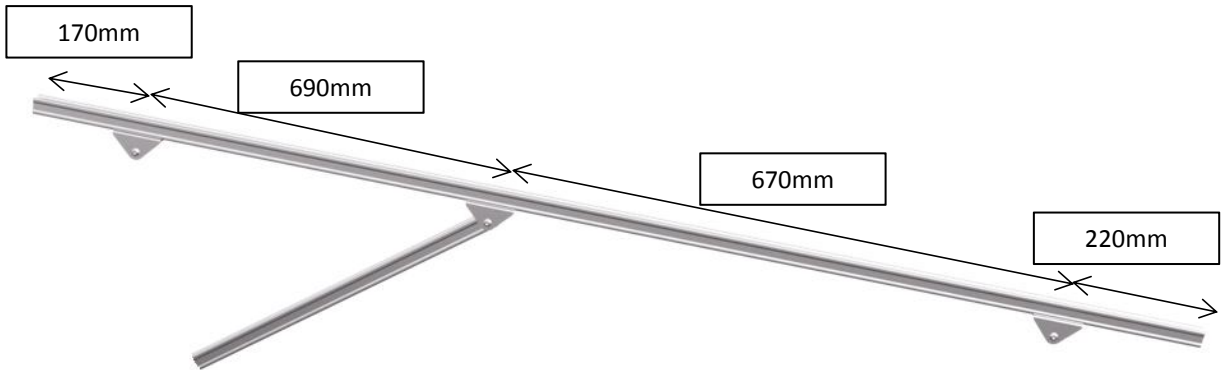

Step4. 5. Install the front leg and rear leg into the splice with M12x80mm bolts.

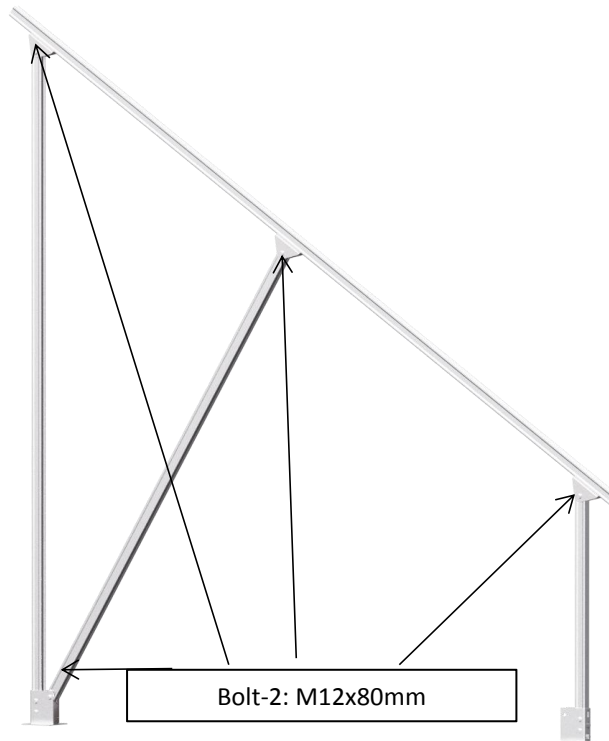

Installation Steps :

Step5. Install the rest mounting structure in same way.



Step6. Fix the structure into the concrete foundation with M12x150mm expansion anchor bolt.

Put the expandable screw into the ground or the hole on the wall and then tighten the nuts of the expansion bolt with wrench. The bolt goes outside while the metal sheath does not move. Thus the bigger head of the bolt will expand the metal sheath, making it fill the whole hole.

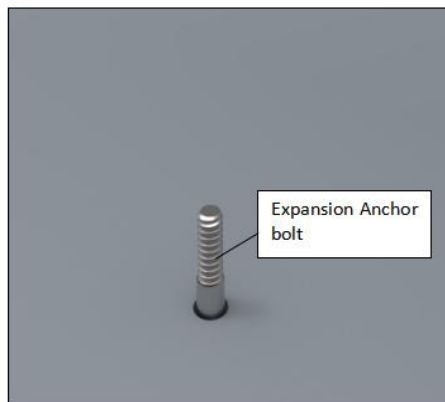
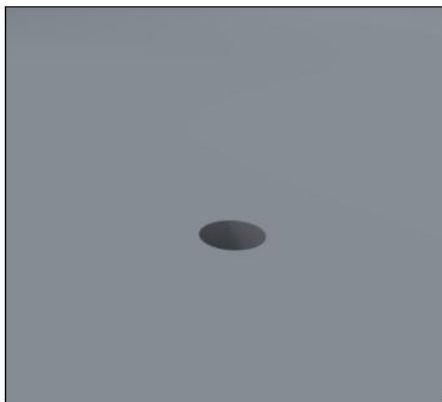
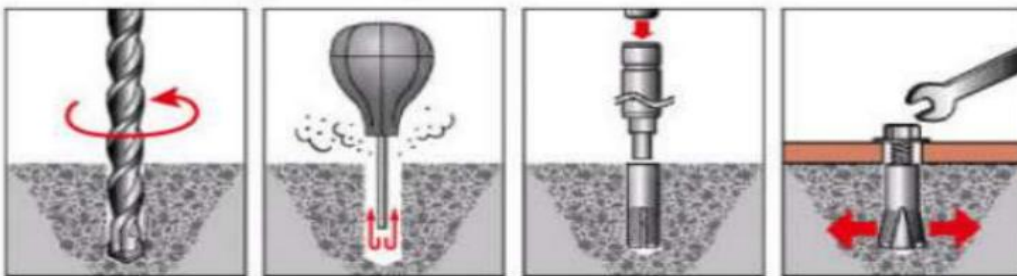

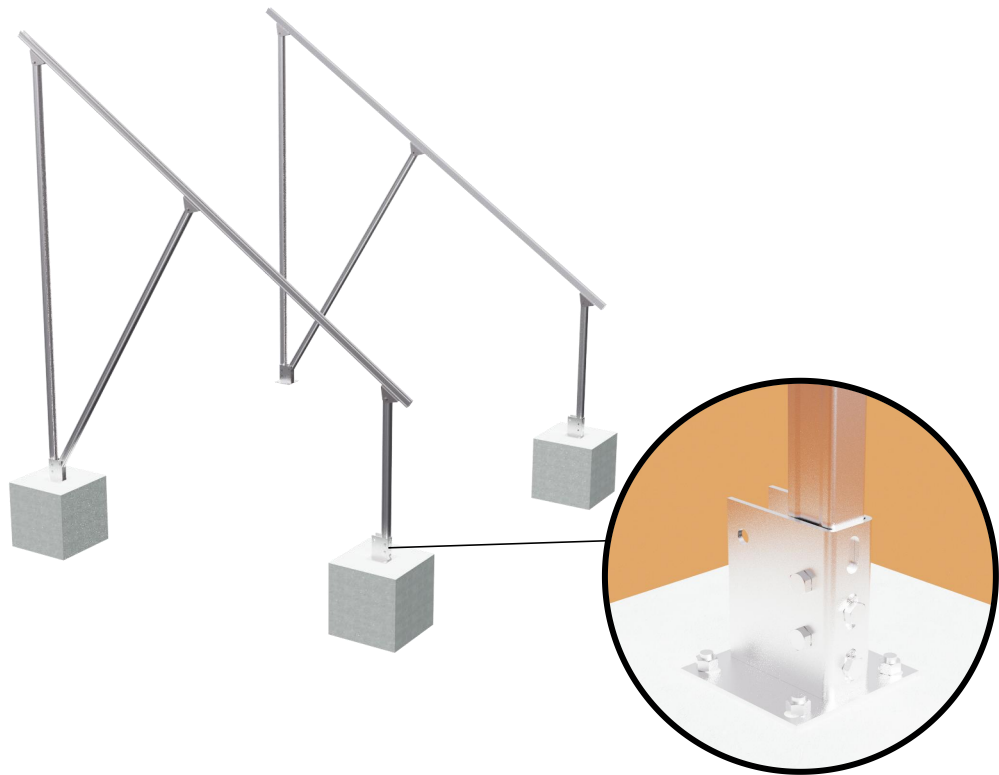

Step7. Connect the rails with rail connectors.





Step8. Install the rails to the beam with M10x30 with nut.

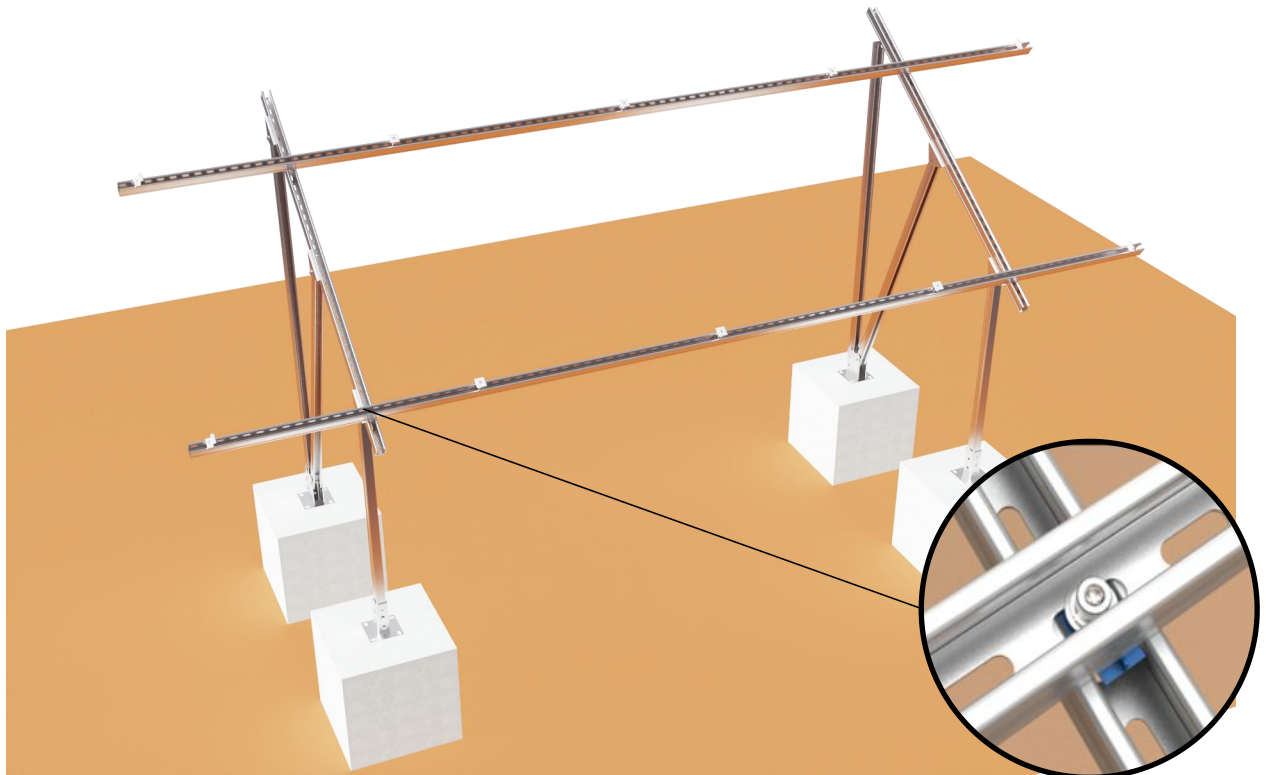

Step9. Fix the Diagonal Strut(41x21x3300mm) to the rear legs with Bolt-3(M10*30+nut) and Bolt-4(M10*30).

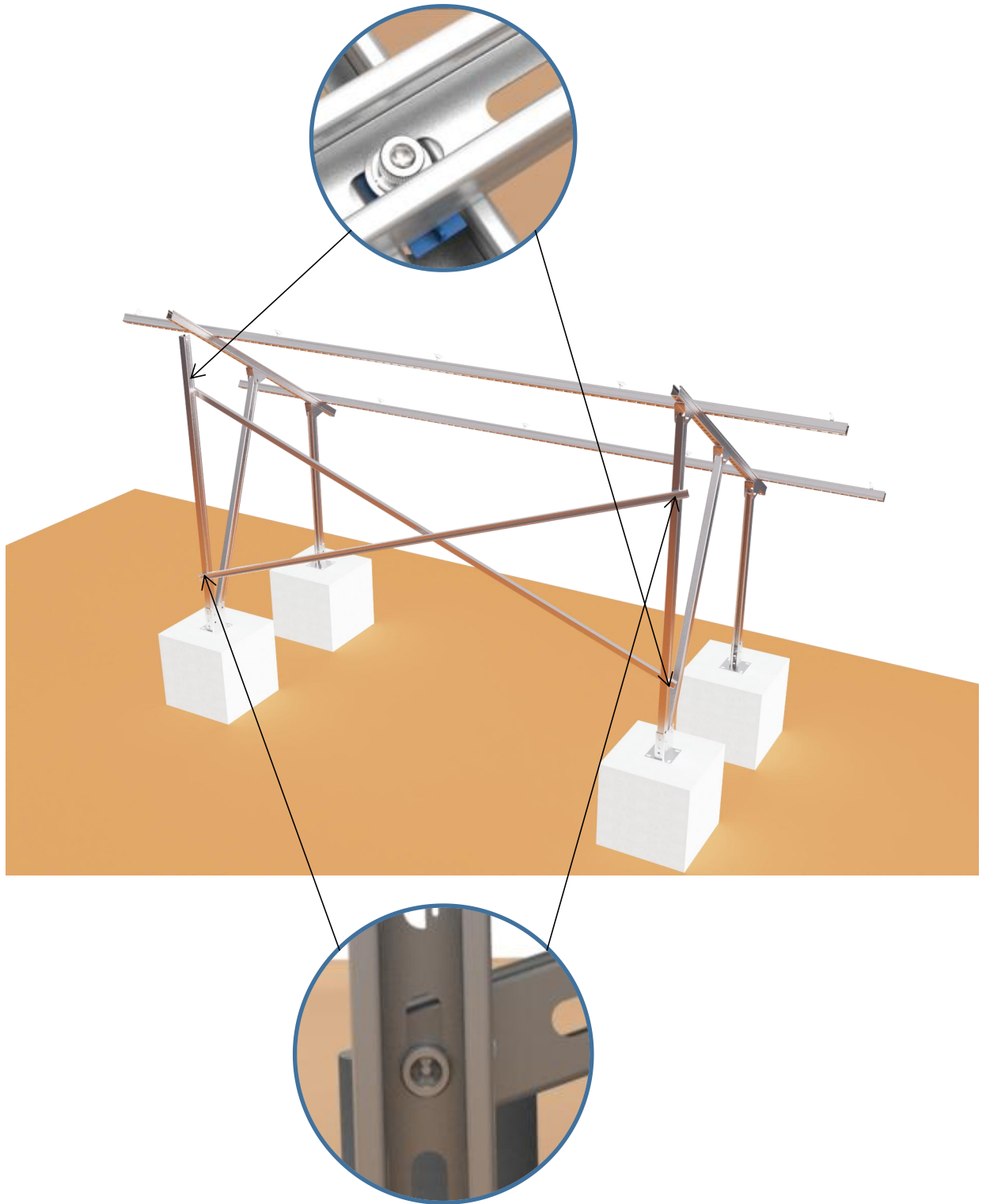

Installation Steps :

Step10. Fix the panels with mid clamps and end clamps.

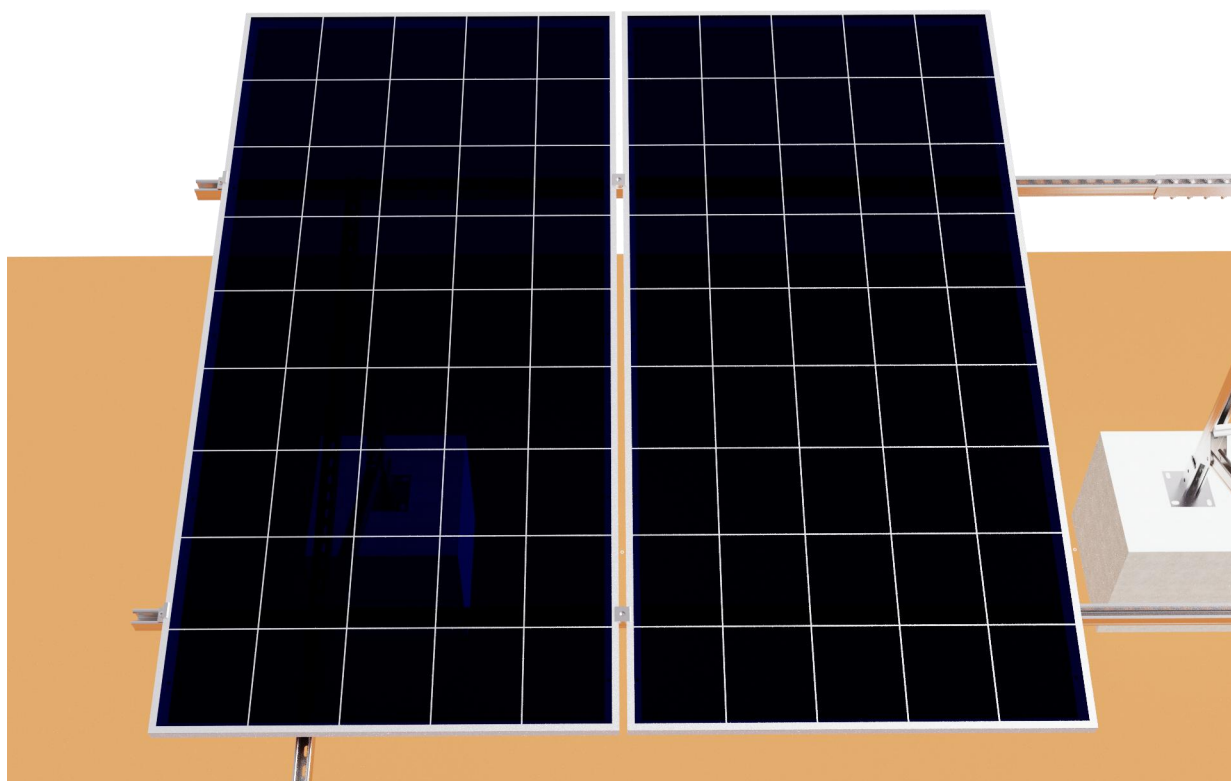

Finished

