

Cuisinart®

Oakmont Pellet Grill and Smoker

ASSEMBLY INSTRUCTIONS

Model SMK2036AS

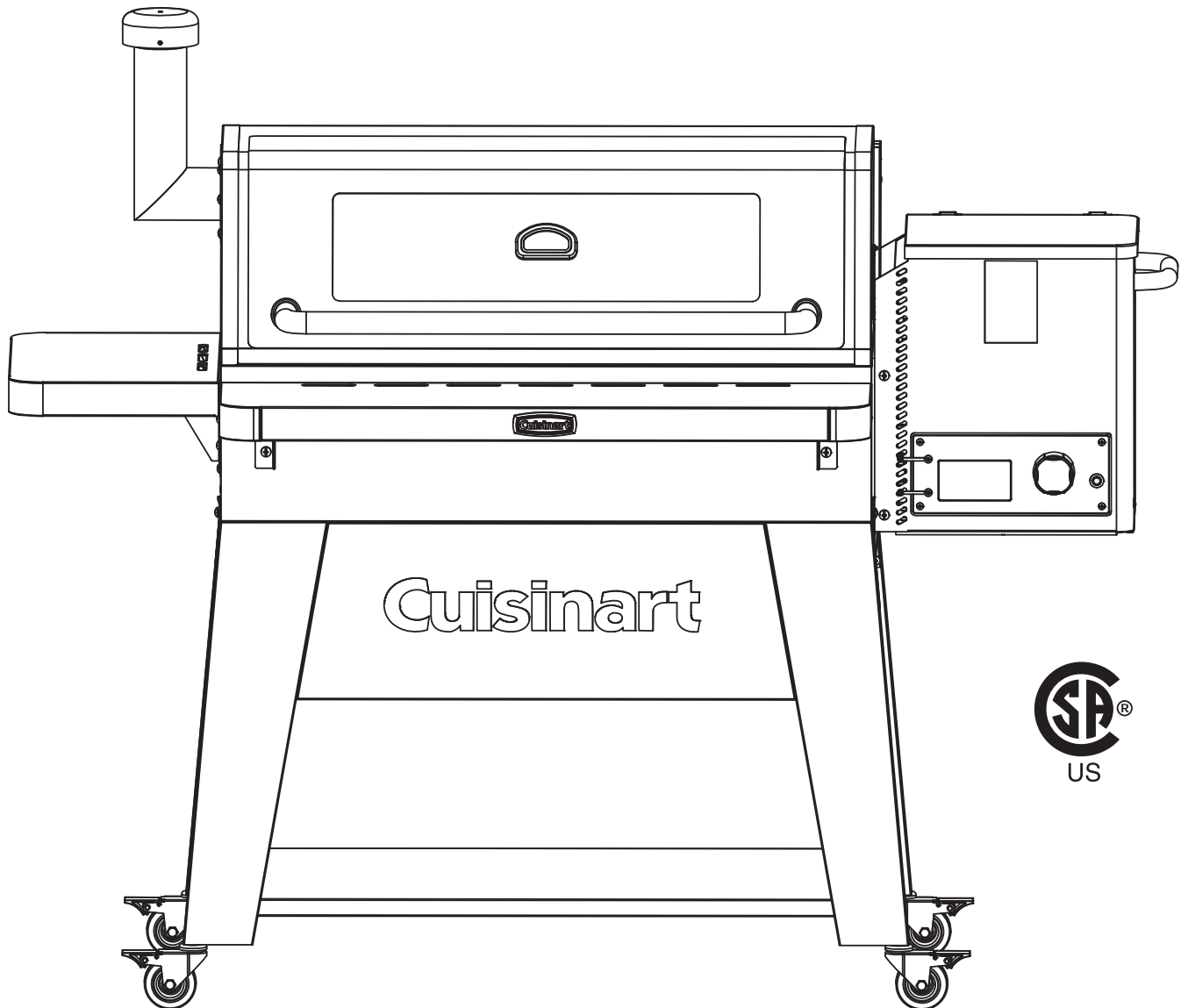

ASSEMBLY INSTRUCTIONS:

⚠ READ ALL SAFETY WARNINGS & ASSEMBLY INSTRUCTIONS CAREFULLY BEFORE ASSEMBLING OR OPERATING YOUR GRILL.

WE RECOMMEND TWO PEOPLE WORK TOGETHER WHEN ASSEMBLING THIS UNIT.

The following tools are required to assemble this Cuisinart Oakmont 3-in-1 Pellet Grill:

- Phillips Screwdriver
- Pliers or Wrench

PARTS LIST:

①	1	Side Table	①9	1	Heat Plate Bracket
②	1	Chimney	②0	1	Hopper Lid
③	1	Hood Handle	②1	4	Casters
④	1	Warming Rack	②2	1	Heat Plate
⑤	1	Rear Cart Brace	②3	1	Ash Clean-out Plate
⑥	2	Right Table Brackets	②4	1	Ash Clean-out Handle
⑦	2	Left Table Brackets	②5	1	Side Handle
⑧	1	Grease Channel	②6	1	Cart Base
⑨	1	Grill Body	②7	1	Front Table
⑩	1	Thermocouple Assembly	②8	1	Pellet Hopper Assembly
⑪	2	Side Cart Braces	②9	1	Cord Wrap
⑫	1	Left Front Leg	③0	1	Cart Front Panel
⑬	1	Right Front Leg	③1	1	Grease Cup Bracket
⑭	1	Left Rear Leg	③2	2	Ash Cup Brackets
⑮	1	Right Rear Leg	③3	1	Heat Baffle
⑯	1	Temperature Gauge Bezel	③4	1	Grease Cup
⑰	1	Temperature Gauge	③5	1	Ash Cup
⑱	4	Cooking Grates	③6	1	Control Knob

Note: Most hardware is pre-attached to the grill. You may need to loosen some screws partially while others may need to be removed in order to assemble parts. The screws that you remove will be re-used so don't misplace this hardware.

Extra screws are included in a small bag with the owners manual.

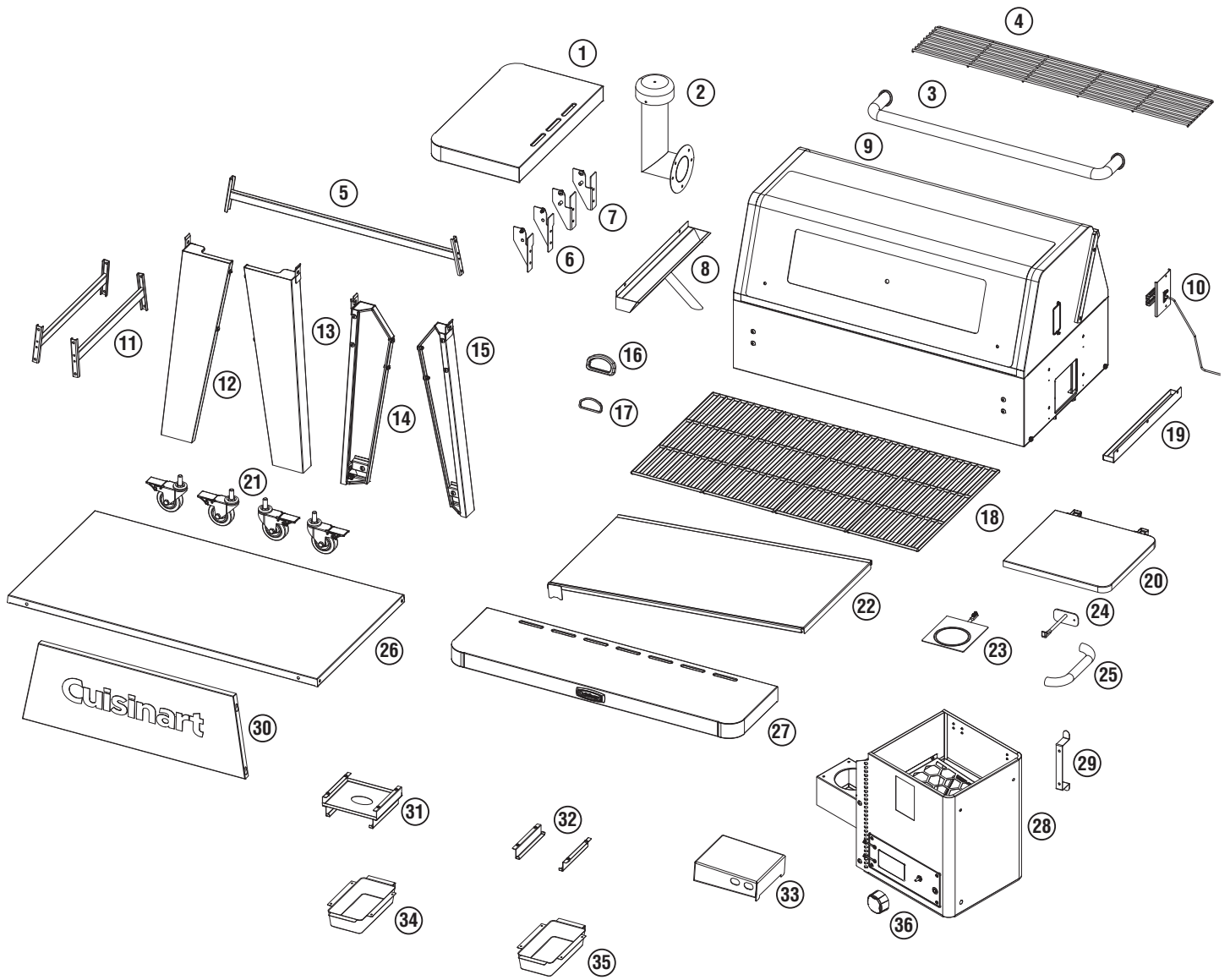

Step 1

- Loosen 4 screws.
- Attach front legs **12** and **13** front panel **30** using keyholes.
- Tighten 4 screws.
- Remove 8 screws.

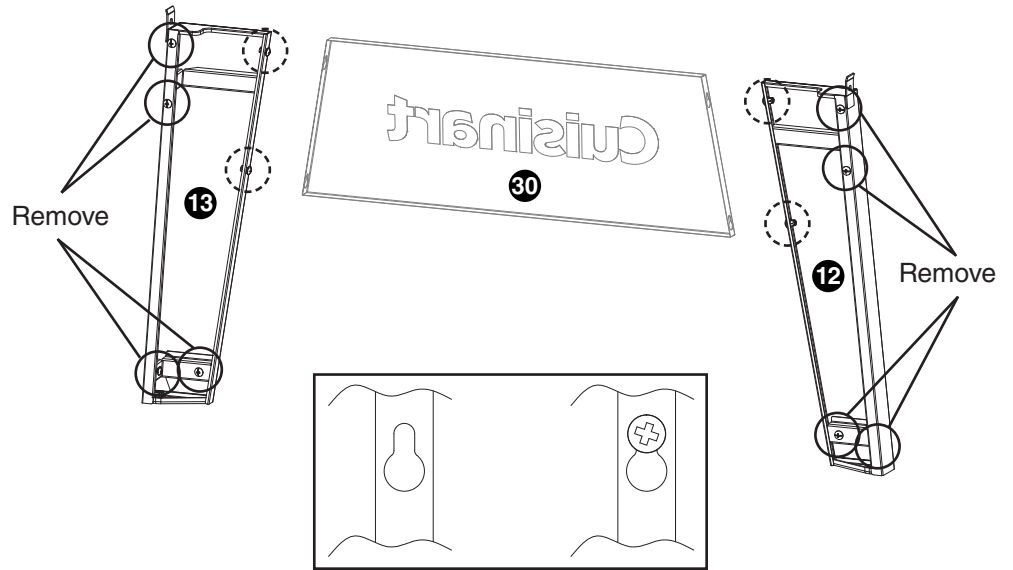

Step 2

- Attach side cart braces **11** to front legs **12** and **13** using 4 screws removed from Step 1.

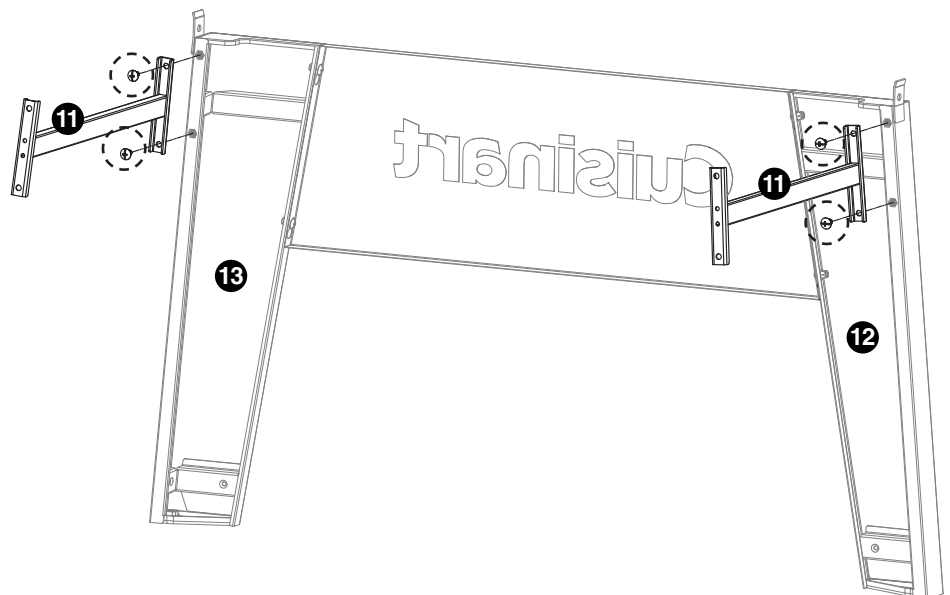

Step 3

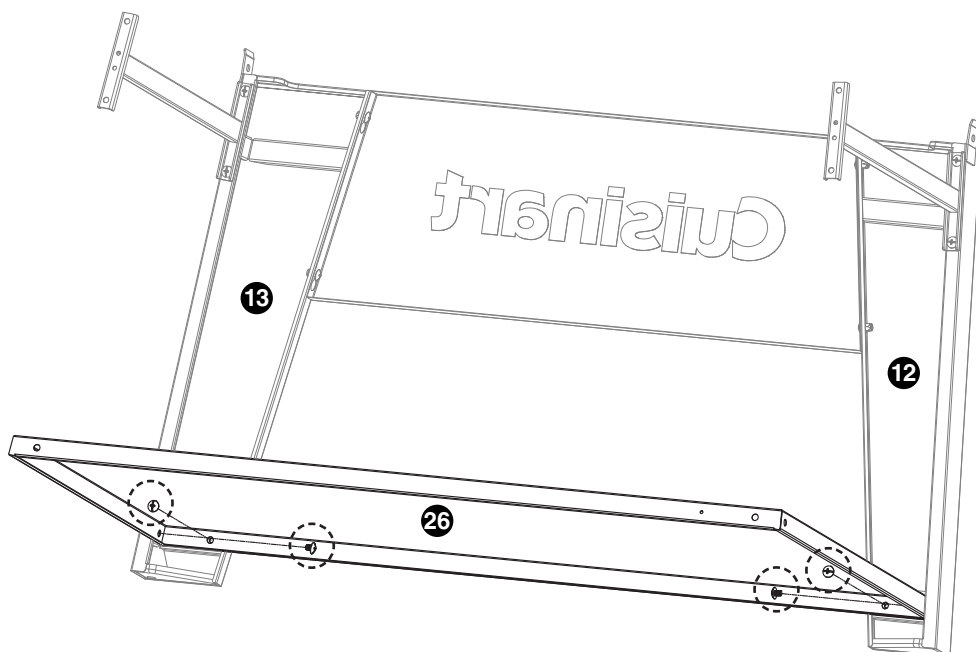

- Attach cart base **26** to front legs **12** and **13** using 4 screws removed from Step 1.

Step 4

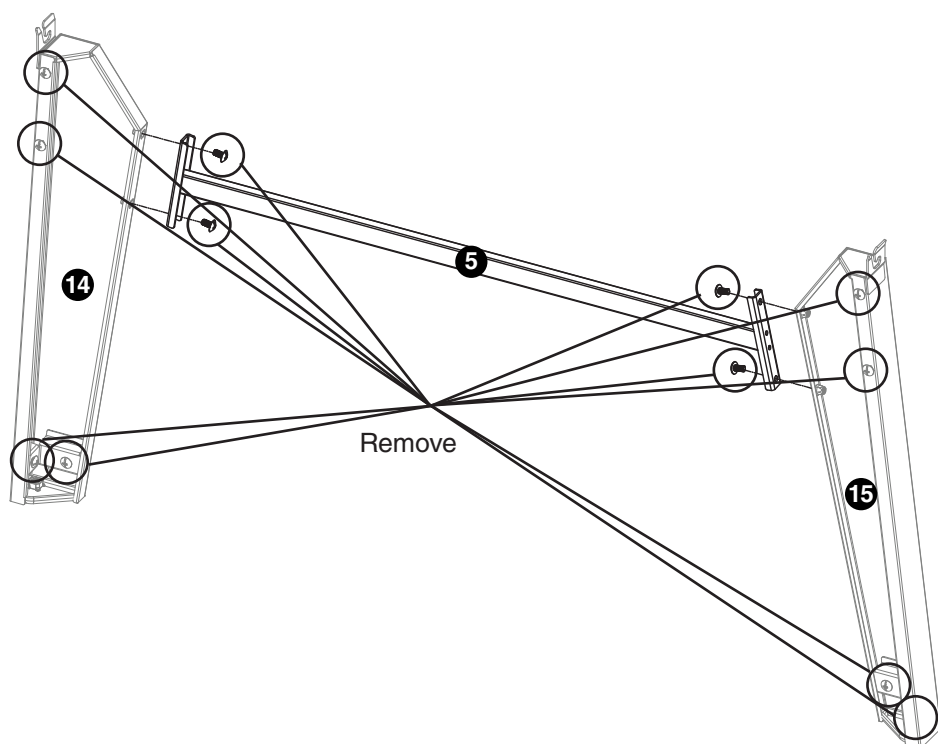

- Remove 12 screws.
- Attach rear cart brace **5** to rear legs **14** and **15** using 4 screws just removed.

Step 5

- Attach side cart braces **11** to rear legs **14** and **15** using 4 screws removed from Step 4.

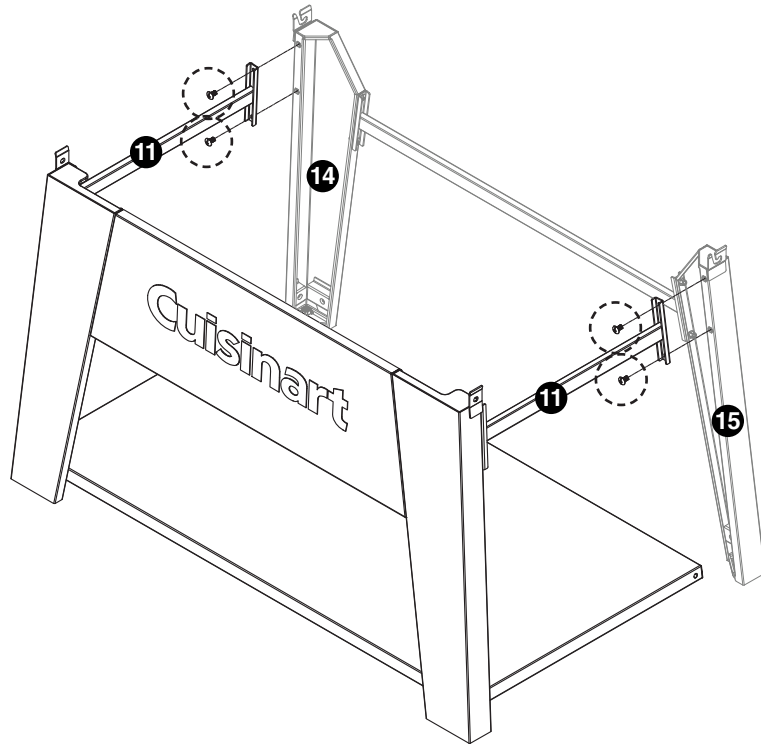

Step 6

- Attach cart base **26** to rear legs **14** and **15** using 4 screws removed from Step 4.
- Tighten all screws.

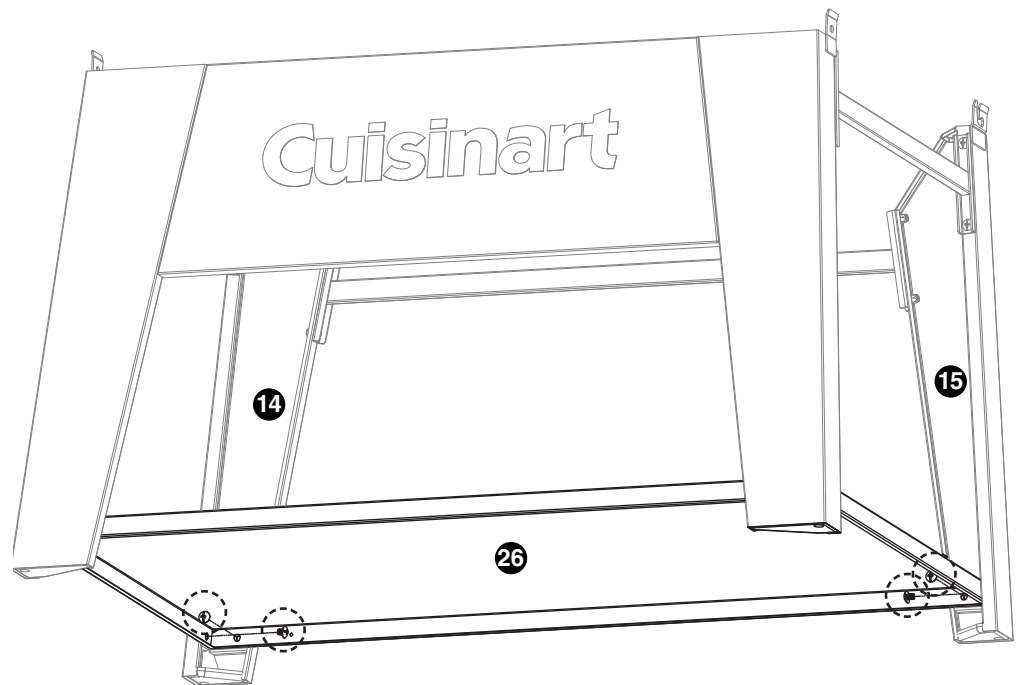

Step 7

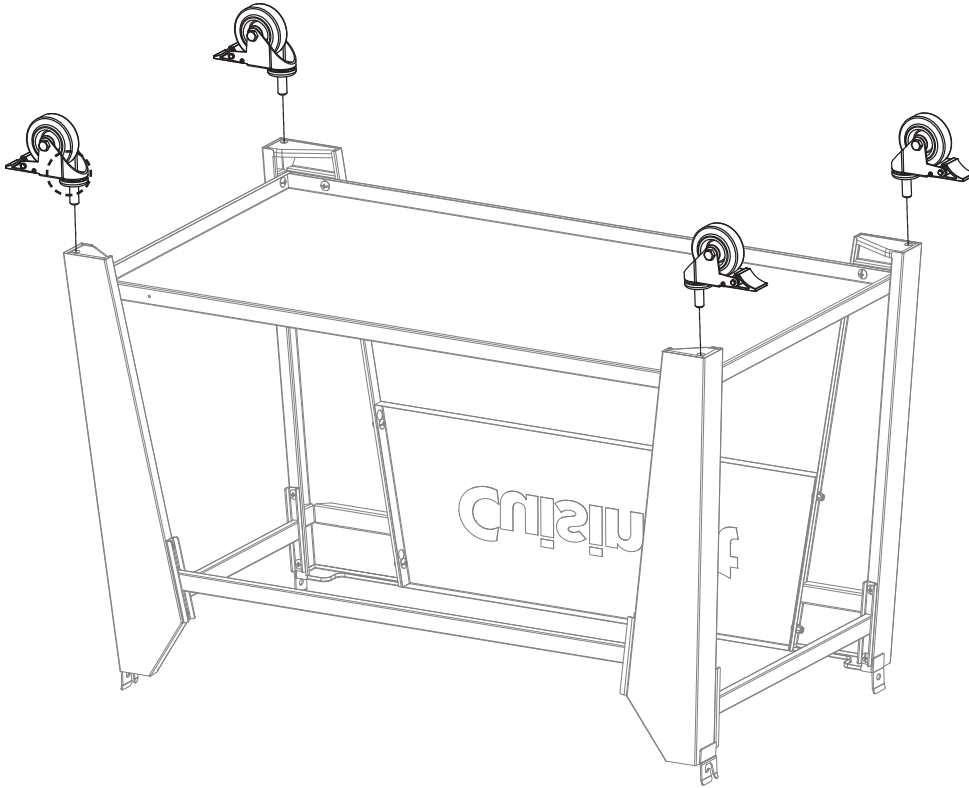

- Lock casters **21**.
- Attach casters **21** to legs.

21 CASTERS

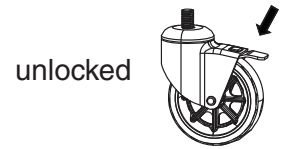

Step 8

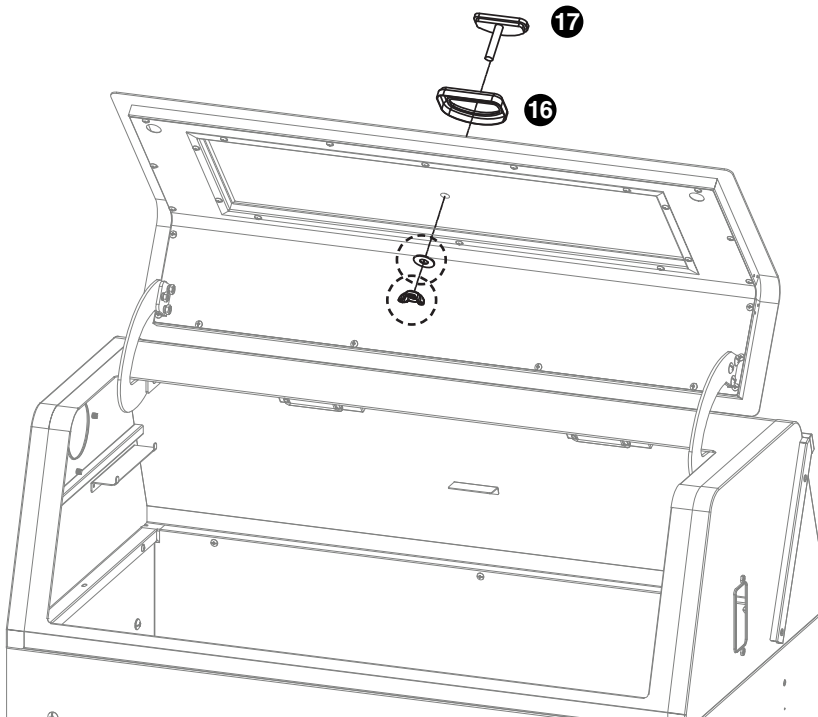

- Attach temperature gauge **17** and bezel **16** to hood using pre-attached washer and wing nut.

Step 9

- Loosen 2 rear screws and remove 2 front screws on both sides of grill body **9**.
- Set grill body **9** on cart. Make sure rear screws drop into cart brackets.
- Install front screws through front brackets.
- Tighten 4 screws.

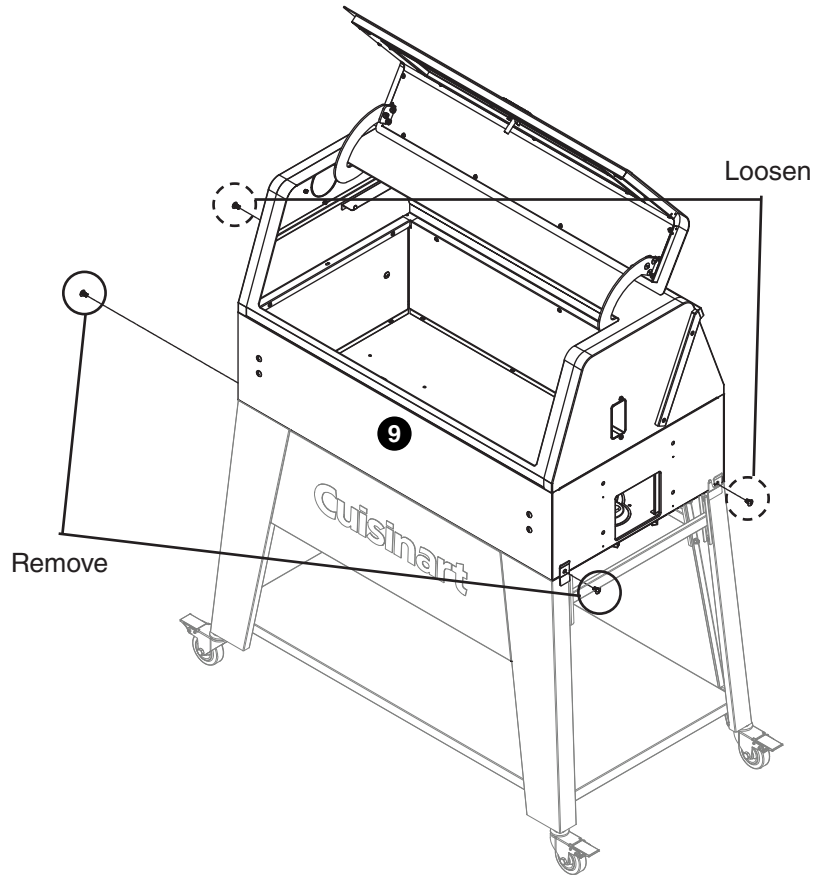

Step 10

- Remove 4 screws from grease cup bracket **31**.
- Attach grease cup bracket **31** to bottom of firebox using 4 screws just removed.

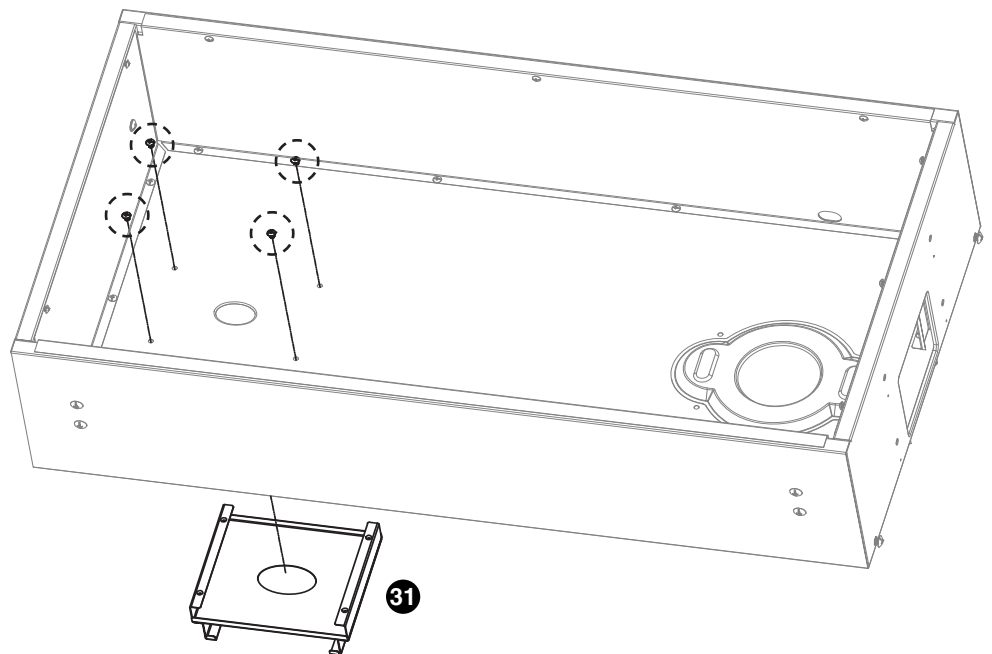

Step 11

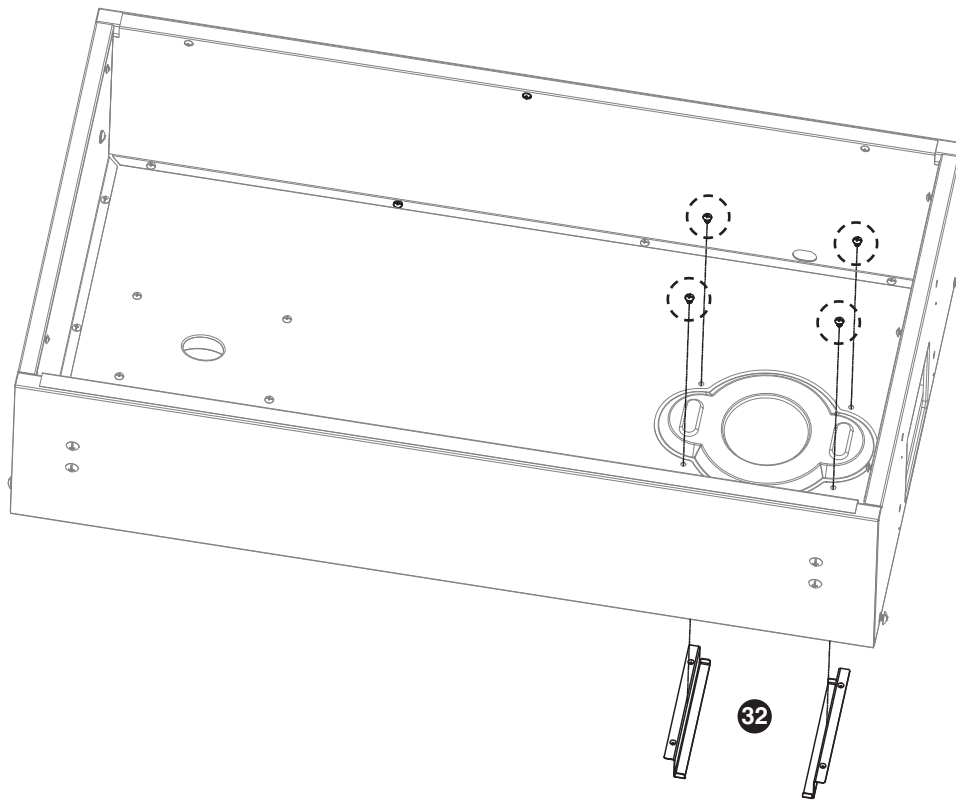

- Remove 4 screws from ash cup brackets 32.
- Attach ash cup brackets 32 to bottom of firebox using 4 screws just removed.

Step 12

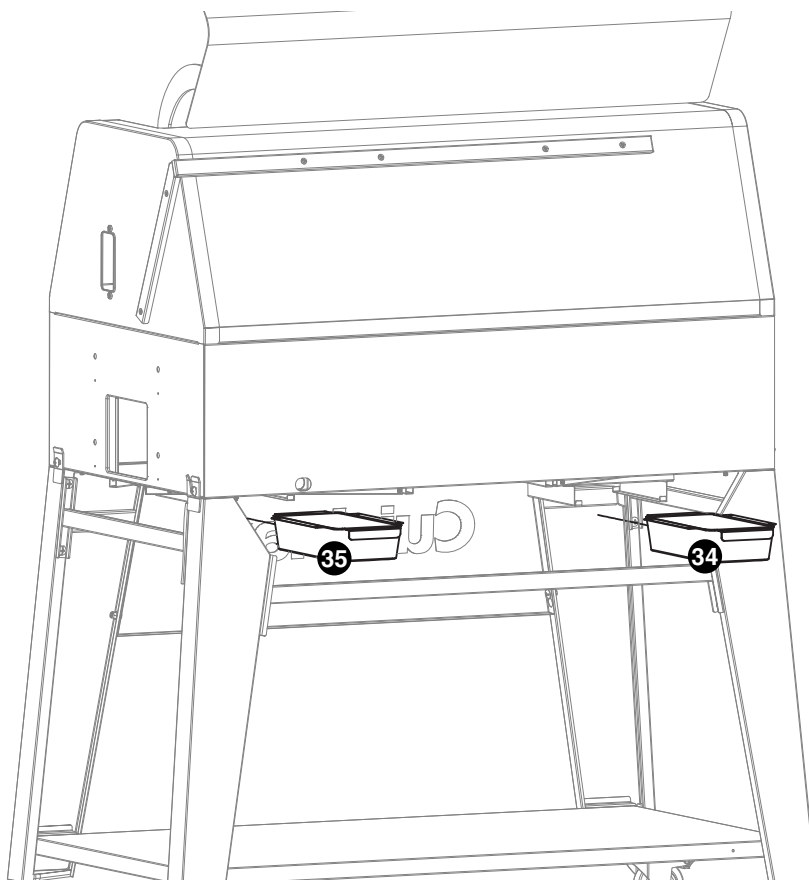

- Install ash cup 35 and grease cup 34.

Step 13

- Remove 2 screws.
- Attach grease channel **8**.
- Tighten 2 screws.

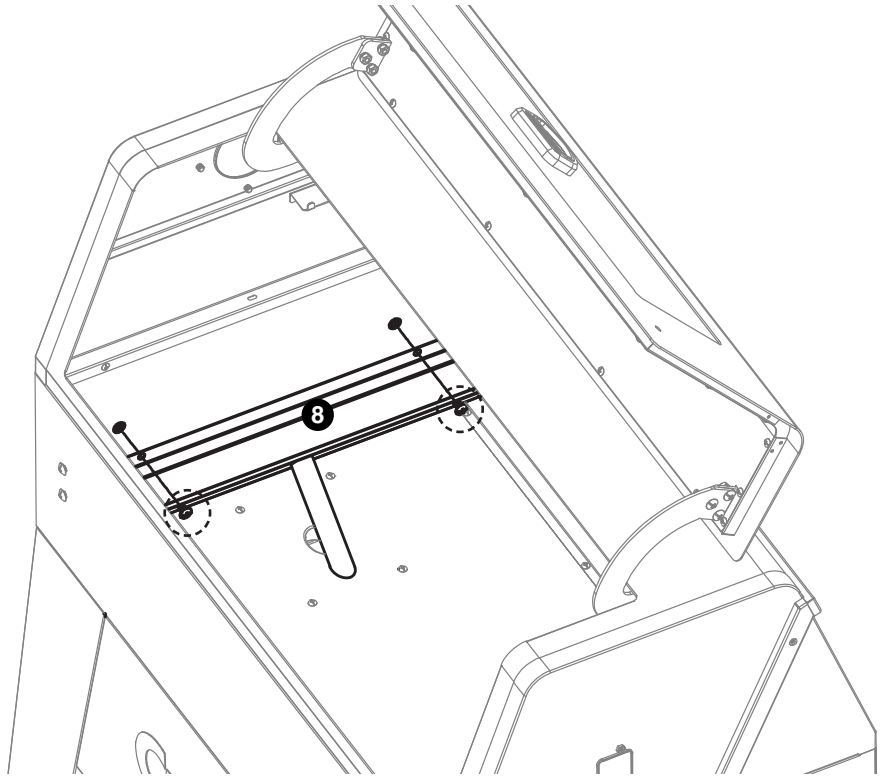

Step 14

- Attach control knob **36** to the controller located on the pellet hopper assembly **28**.

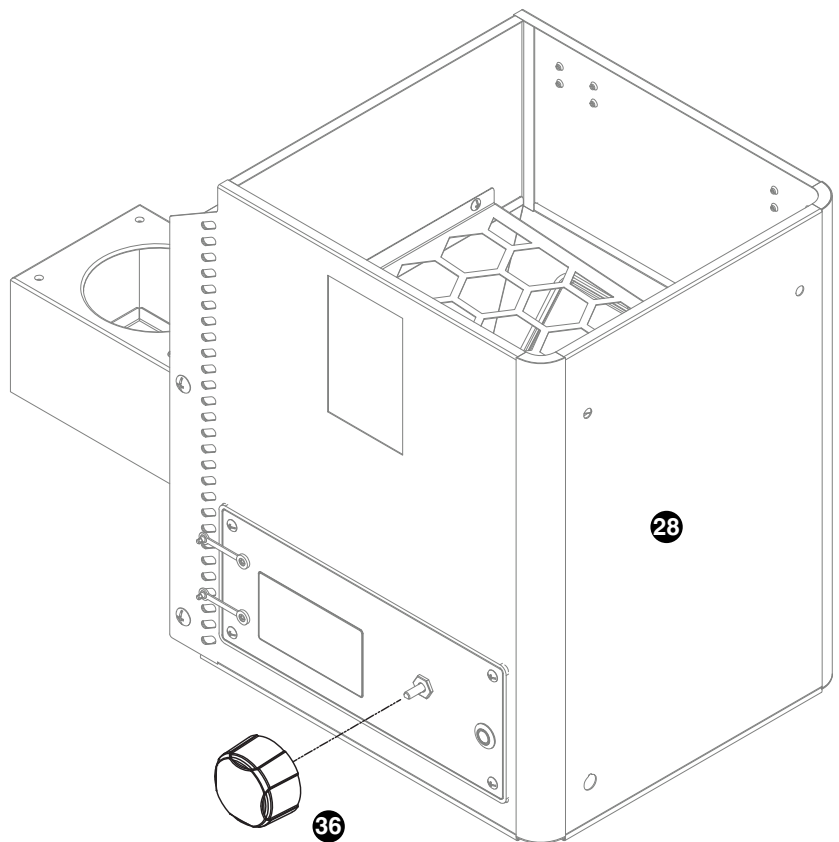

Step 15

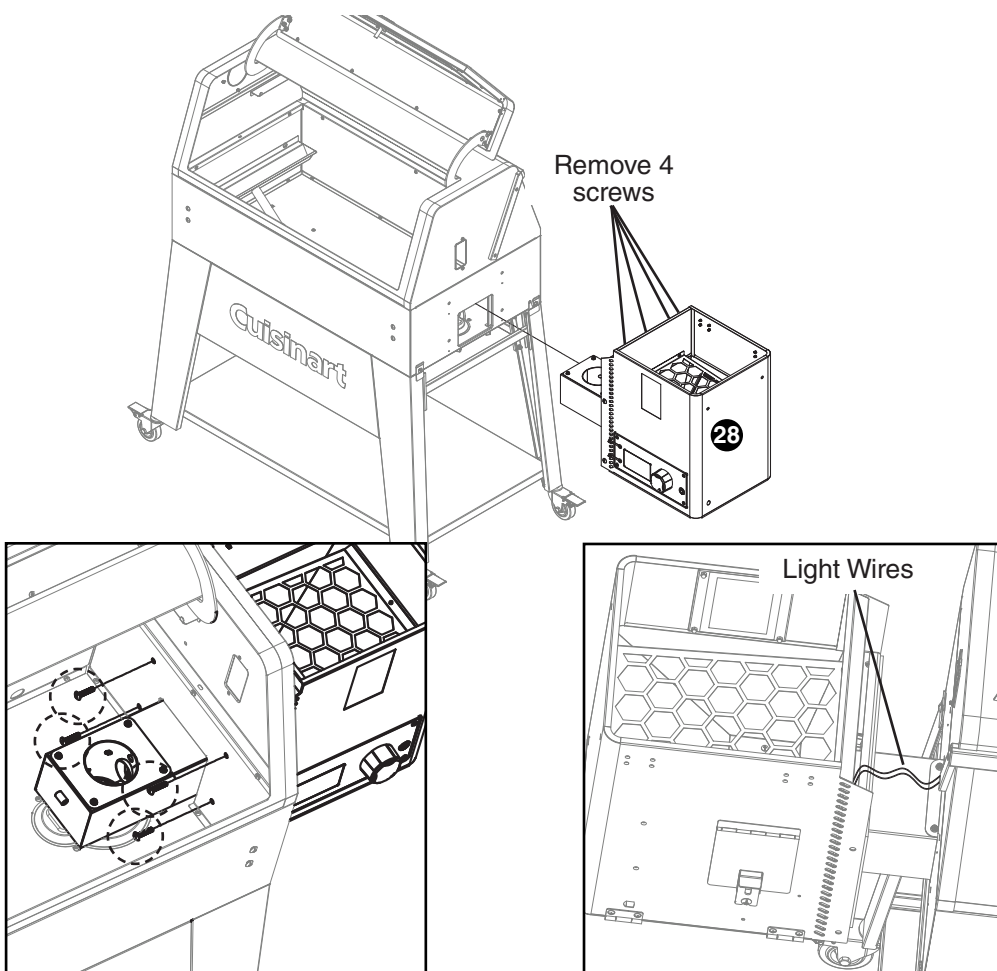

- Remove 4 pre-attached screws.
- Install pellet hopper assembly **28** into grill body.
- Attach pellet hopper assembly **28** to grill body using 4 pre-attached screws.
- Tighten 4 screws.

Note: When assembling the pellet hopper to the grill, the light wires should be fed through the back side of the auger box to ensure there is enough wire to connect during Step 29b.

Step 16

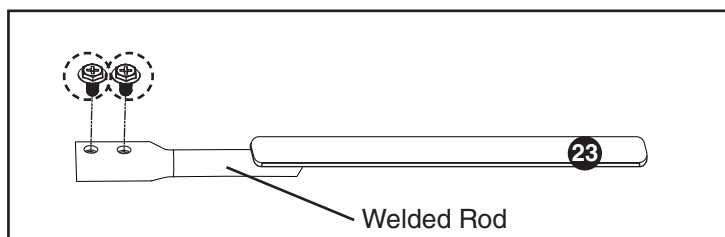

- Remove 2 screws from ash clean-out plate **23** and set aside for later use.
- Slide ash clean-out plate **23** into bottom of auger housing.

Note: The welded rod should be on the bottom when installed.

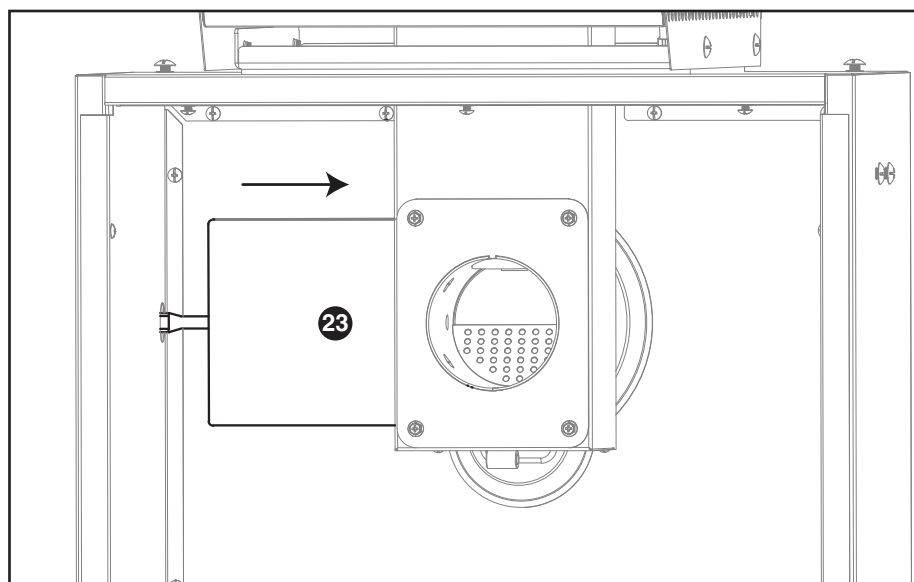

Step 17

- Insert ash clean-out handle **24** through back of grill body.
- Attach ash clean-out handle **24** to ash clean-out plate **23** using 2 screws removed from Step 16.

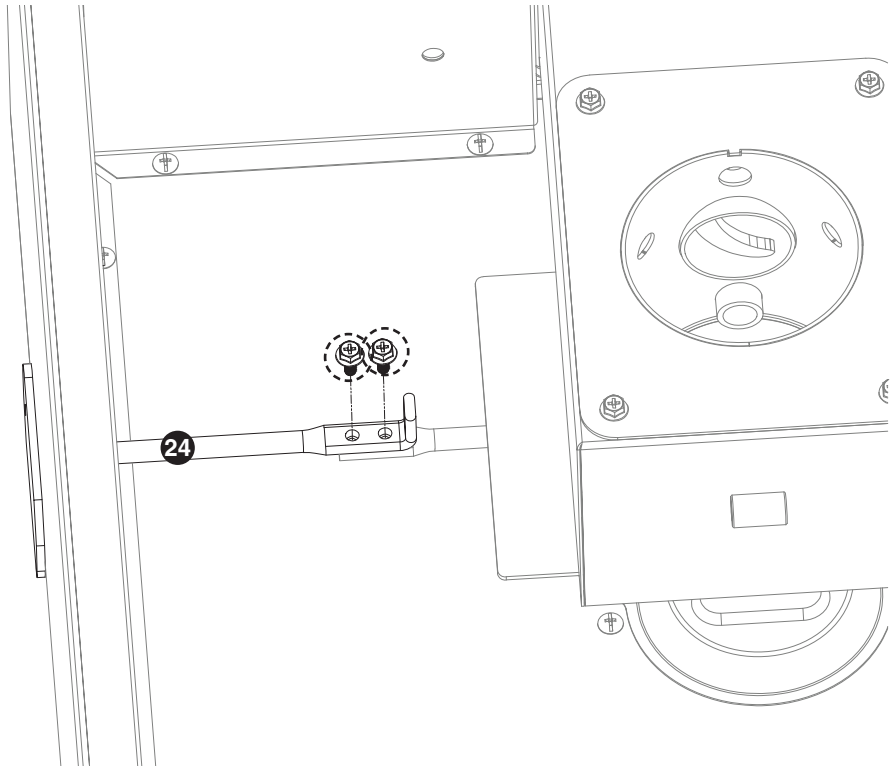

Step 18

- Remove 3 screws.
- Attach heat plate bracket **19** using 3 screws just removed.

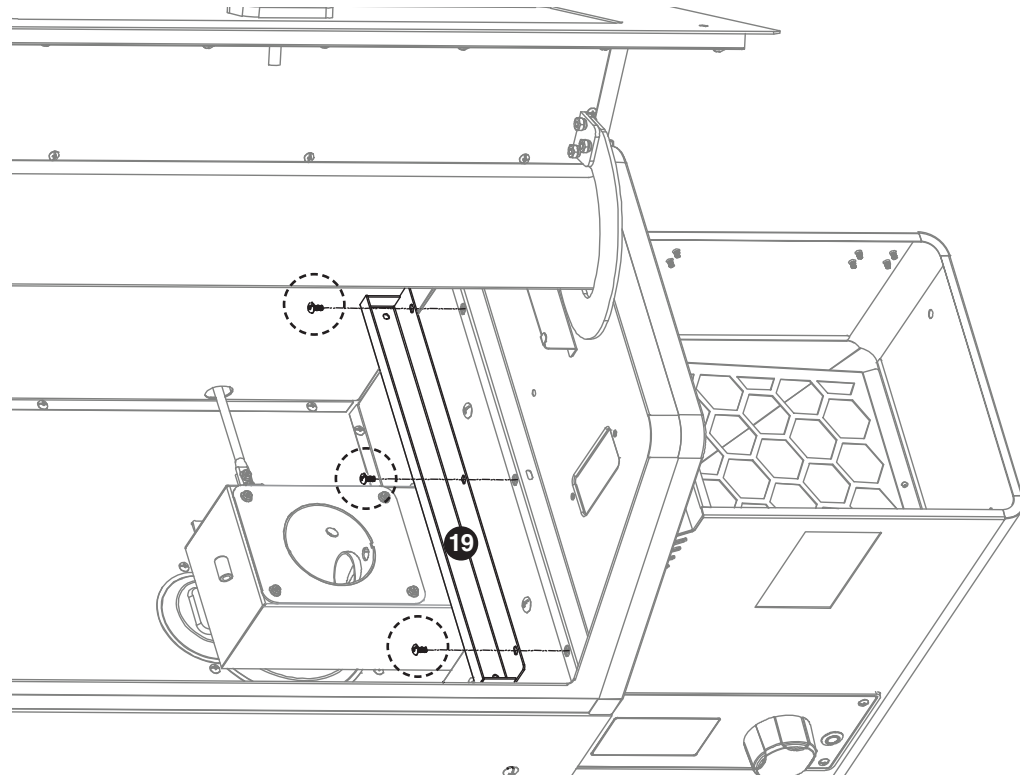

Step 19

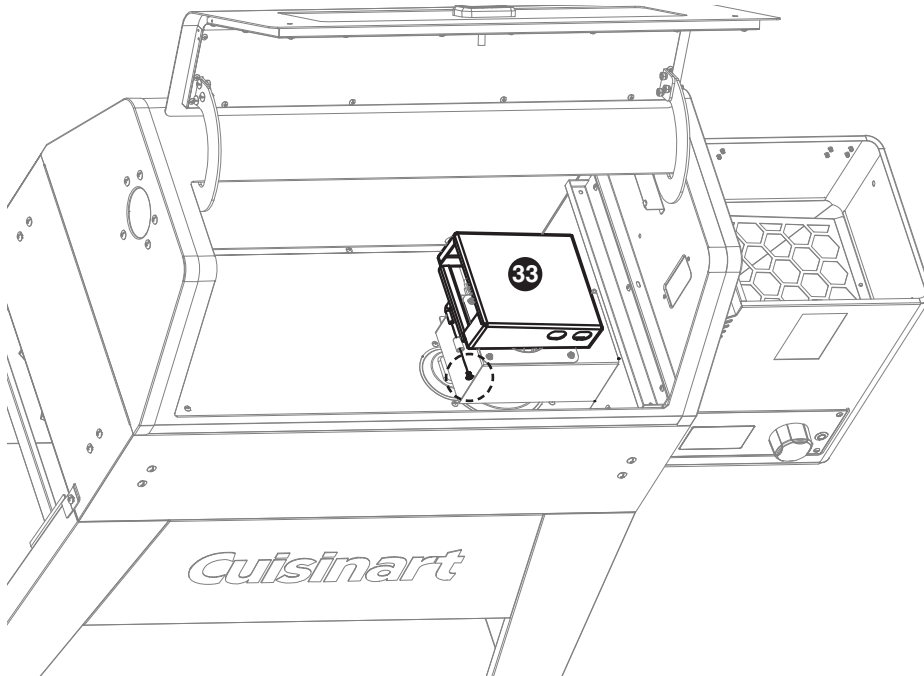

- Remove 1 screw from heat baffle 33.
- Insert the heat baffle pin into auger box and tighten screw to hold in place.

Step 20

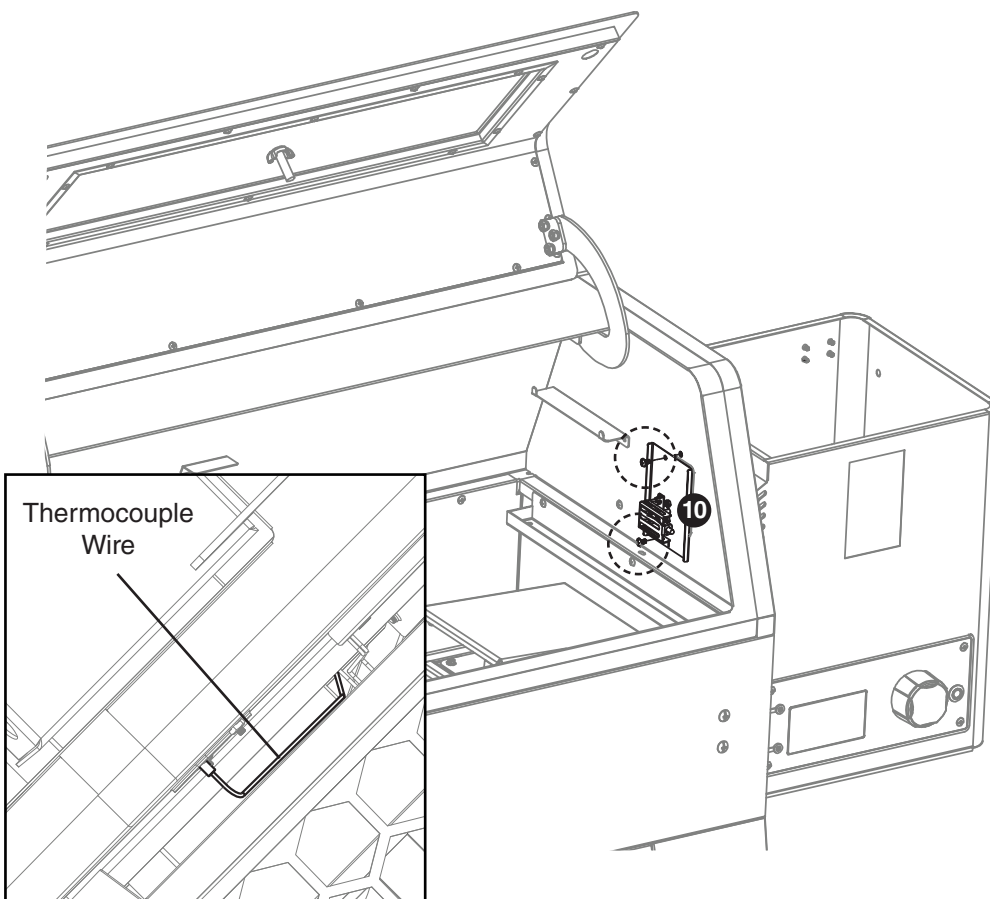

- Remove 2 screws.
- Attach thermocouple assembly 10 using 2 screws just removed.

Note: Make sure to feed the thermocouple wire on the back side of the auger box to ensure there is enough wire to connect during Step 29b.

Step 21

- Attach side handle **25** using 2 pre-attached screws and washers from side handle.

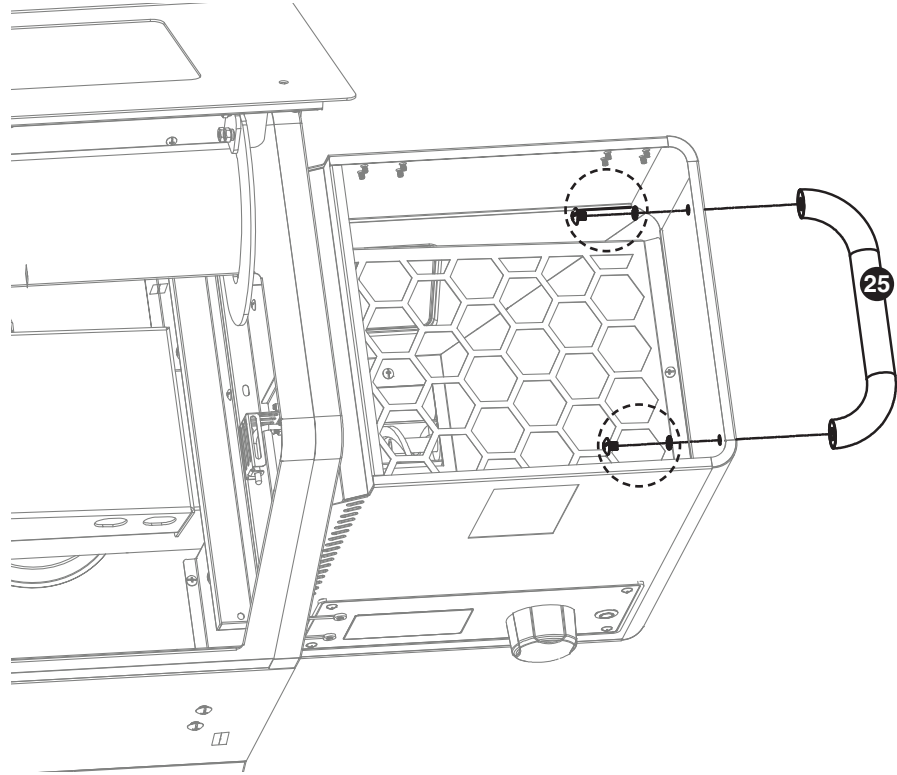

Step 22

- Remove 8 screws.
- Attach hopper lid **20** to pellet hopper body using 8 screws just removed.

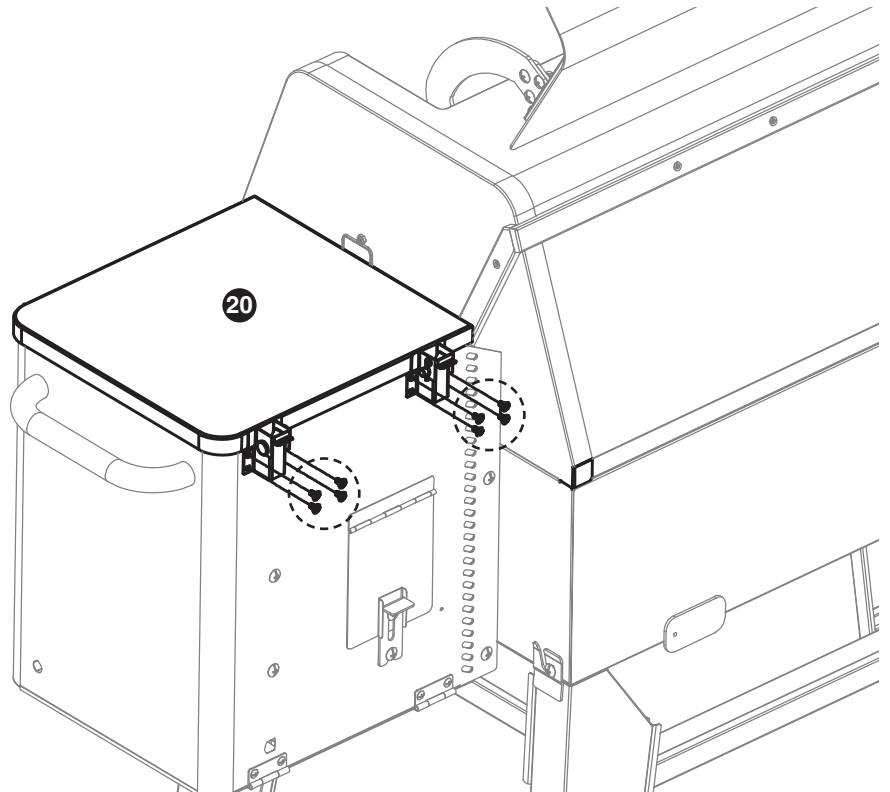

Step 23

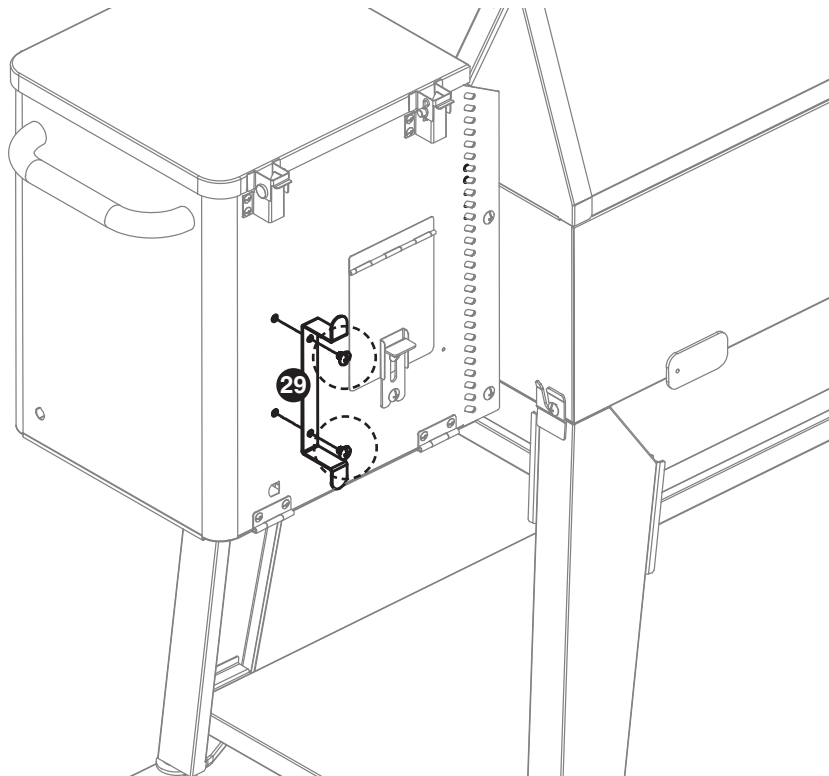

- Remove 2 screws.
- Attach cord wrap **29** using 2 screws just removed.

Step 24

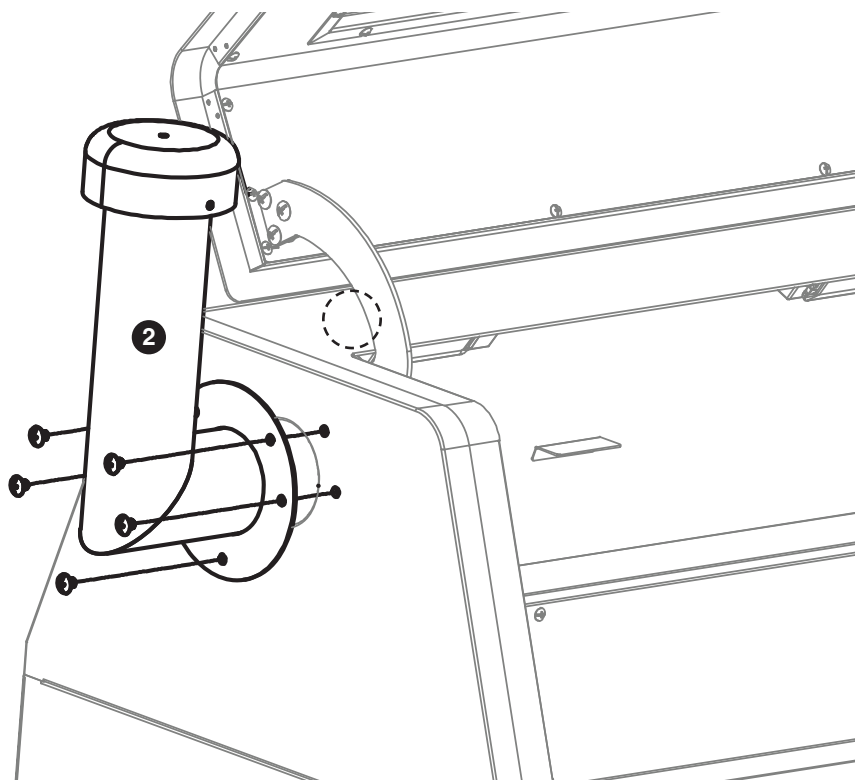

- Remove 5 screws.
- Attach chimney **2** using 5 screws just removed.

Step 25

- Install hood handle **3** using screws and bezels pre-installed on handle.

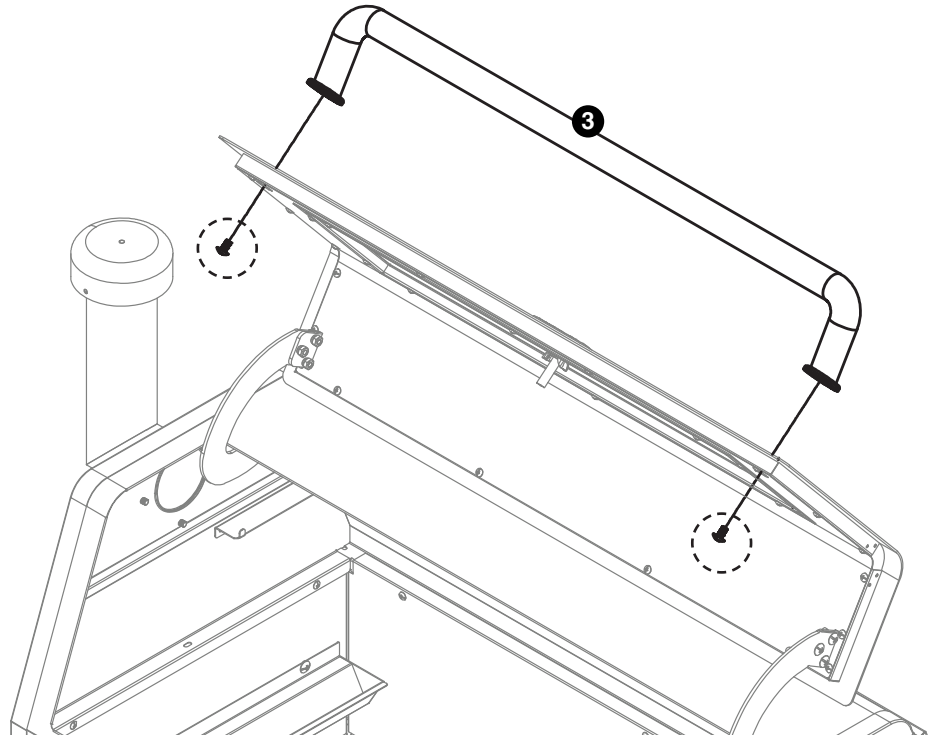

Step 26

- Attach left and right table brackets **7** and **6** to grill body using four pre-attached bolts.
- Remove two pre-attached bolts from left and right table brackets **7** and **6** and attach side table to brackets using bolts just removed.

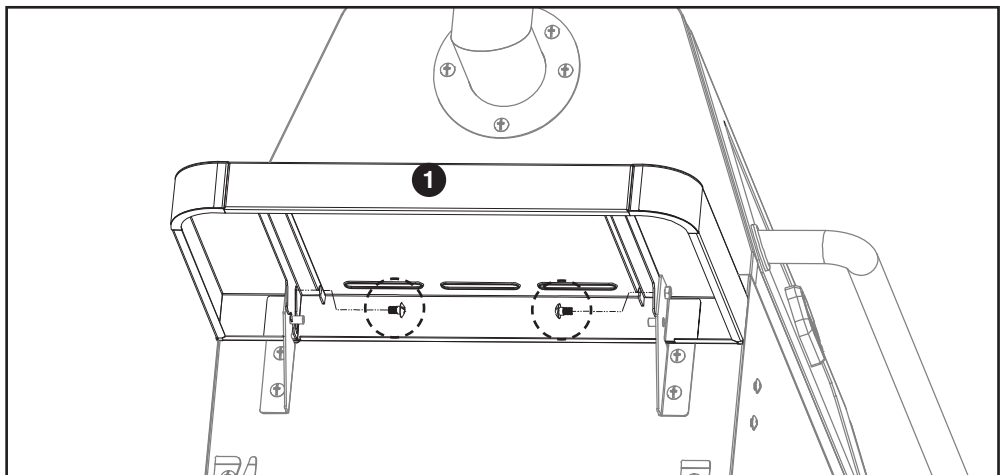
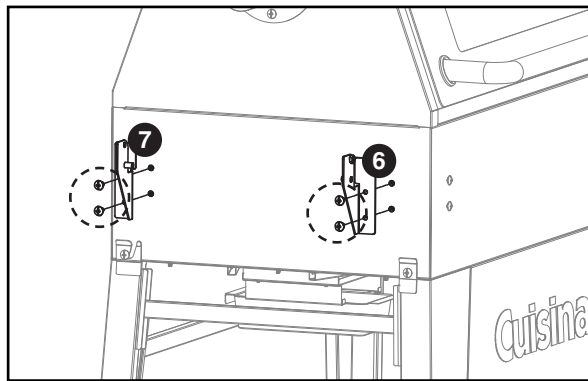

Step 27

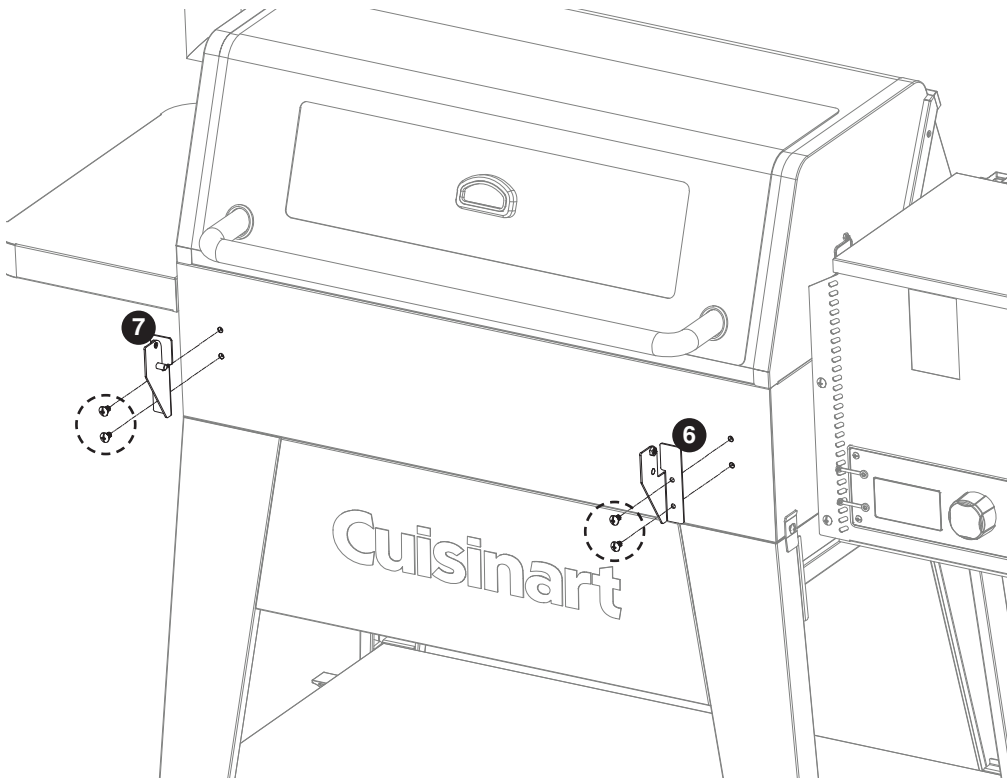

- Attach left and right table brackets **7** and **6** to grill body using four pre-attached bolts.

Step 28

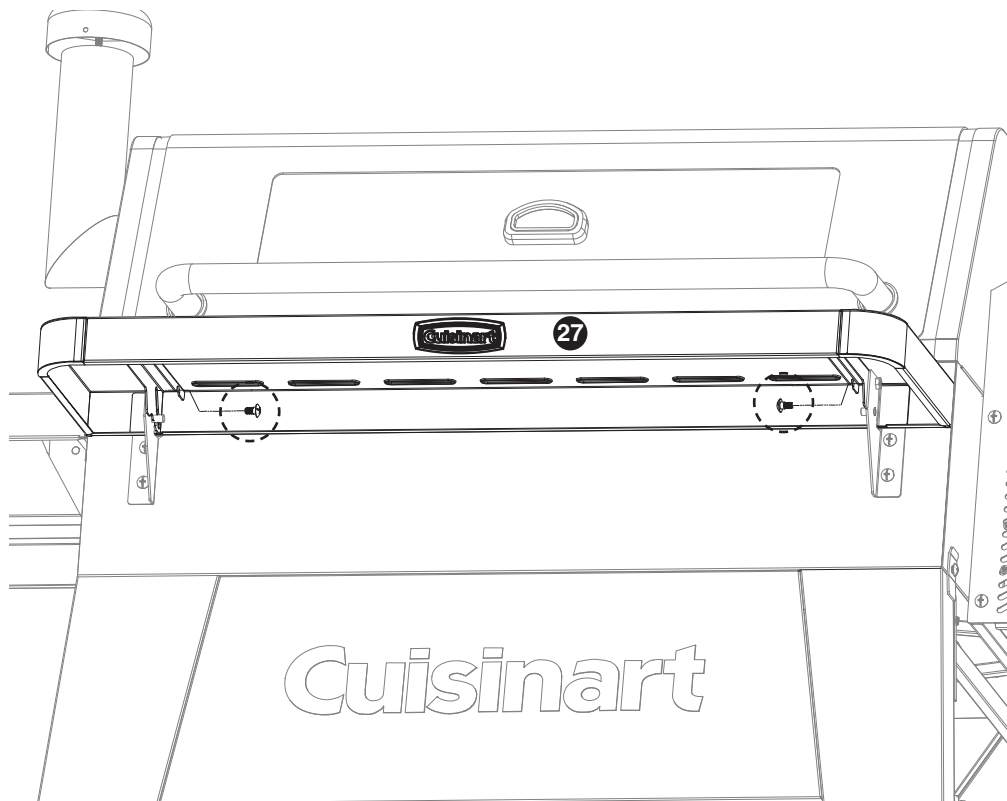

- Remove two pre-attached bolts from left and right table brackets **7** and **6** and attach front table to brackets using bolts just removed.

Step 29a

- Remove 1 screw from the bottom of pellet hopper panel.

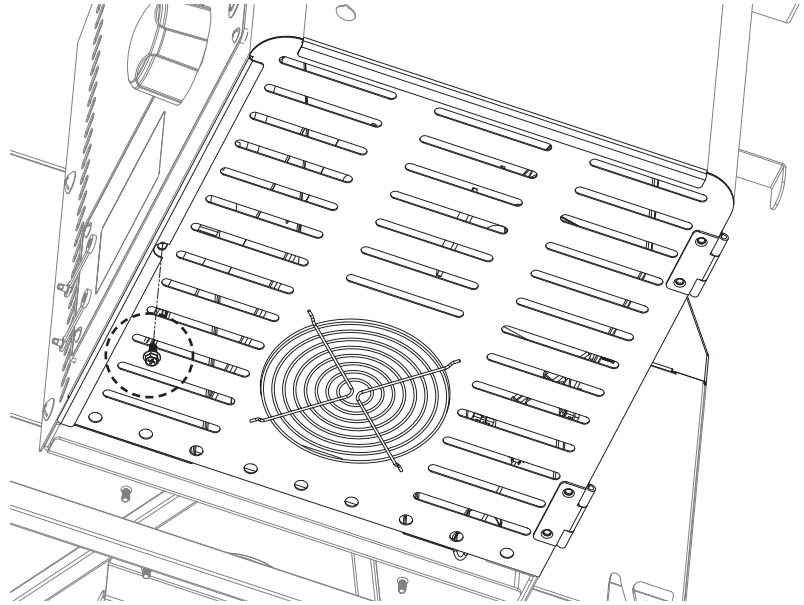

Step 29b

- Connect the thermocouple connector and the two 10 watt light connectors. These wires can only be connected one way.

Note: All connectors must be connected in order for the grill to function properly.

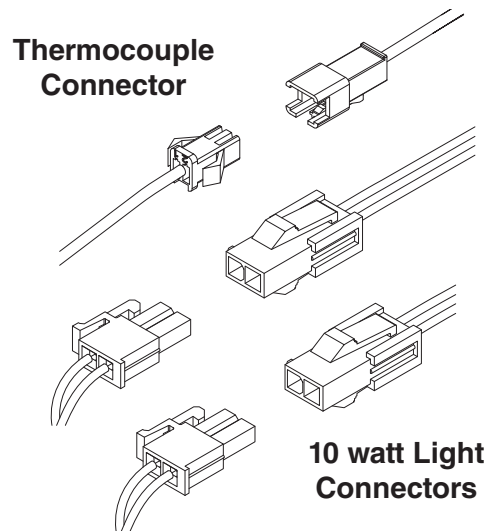

Step 29c

- Run wires through wire holder and secure in place.
- Close pellet hopper bottom panel and secure with screw.

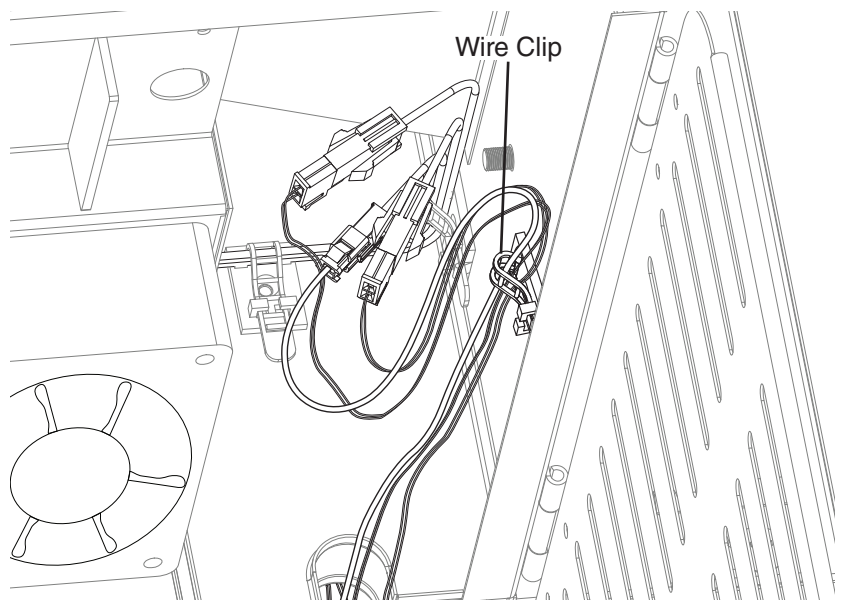

Step 30

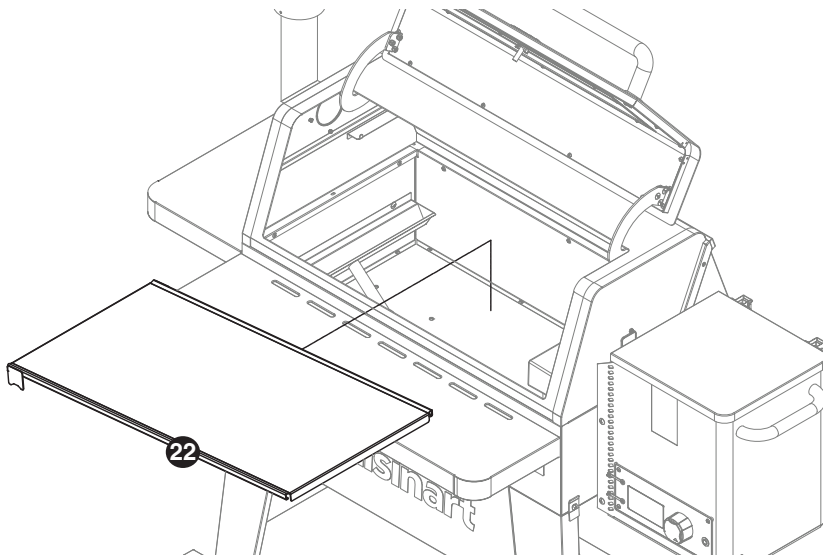

- Place heat plate **22** inside cooking chamber on brackets.

Note: The heat plate should set in the grease channel and the heat plate bracket. Once installed the heat plate will slope down to the left to ensure grease flows into the grease cup.

Step 31

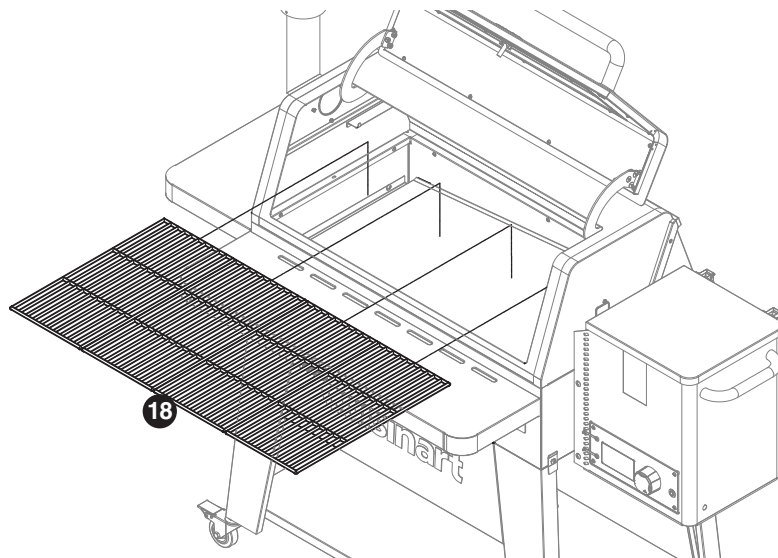

- Place 4 cooking grates **18** inside cooking chamber.

Step 32

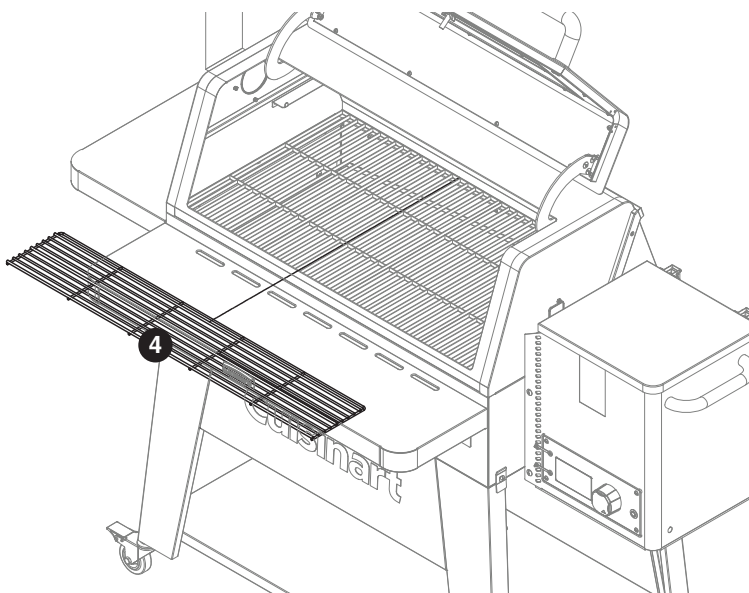

- Place the warming rack **4** on supports inside cooking chamber.

Model SMK2036AS Assembled

