

**KDE6213XF-185 (HE) KDE DIRECT UAS BRUSHLESS MOTOR
PRODUCTION RELEASE**

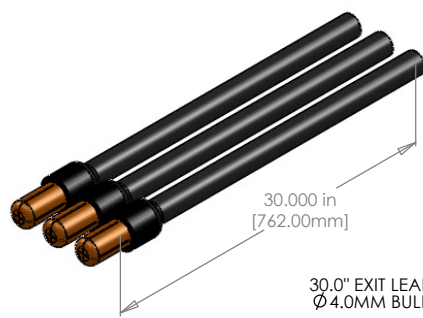
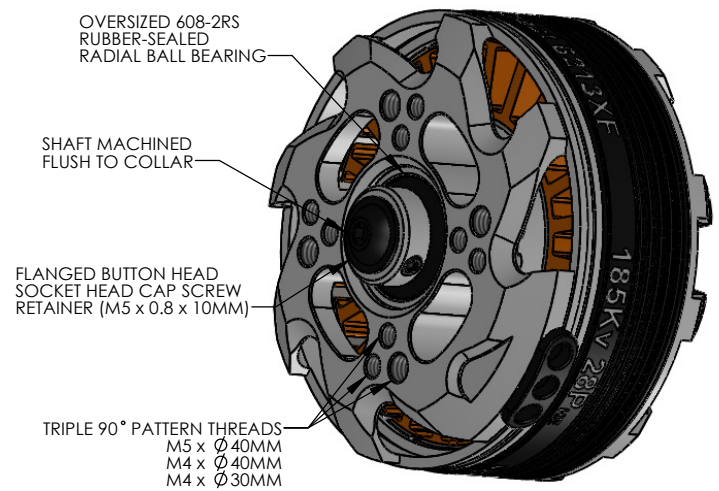
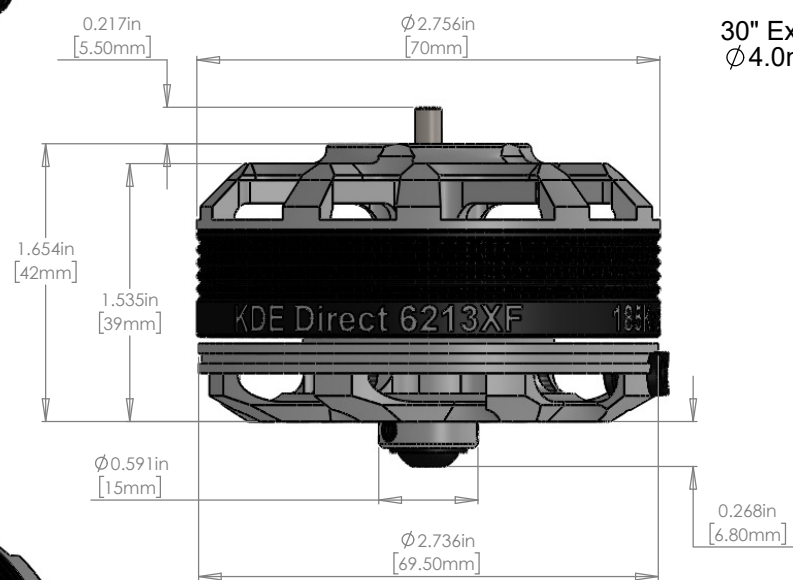
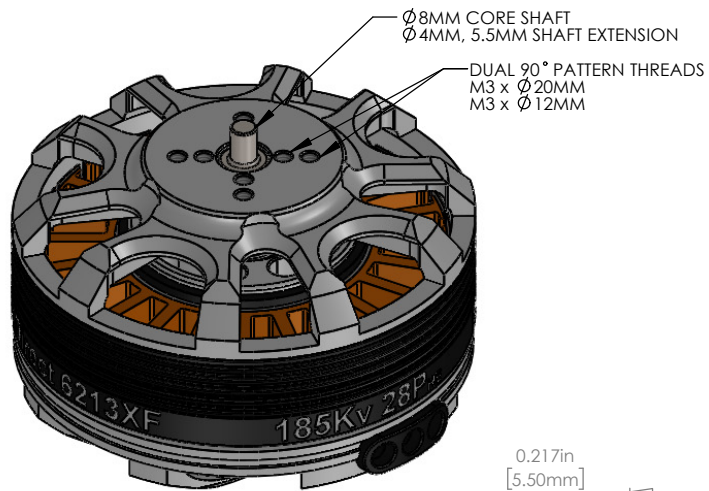

KDE DIRECT UAS BRUSHLESS MOTOR SPECS.

- \varnothing 8mm Core Shaft
- \varnothing 4mm, 5.5mm Extended Length
- Shaft Flush with Retaining Collar
- 698-2RS Upper Bearing (\varnothing 8mm x \varnothing 19mm x 6mm)
- Double Upper Bearings
- 608-2RS Lower Bearing (\varnothing 8mm x \varnothing 22mm x 7mm)
- All Bearings Dual Rubber-Sealed (2RS)

Dual 90° Pattern Threads:
 M3 Threads x \varnothing 20mm Spacing
 M3 Threads x \varnothing 12mm Spacing

Triple 90° Pattern Threads:
 M5 Threads x \varnothing 40mm Spacing
 M4 Threads x \varnothing 40mm Spacing
 M4 Threads x \varnothing 30mm Spacing

30" Exit Lead Extensions (14 AWG)
 \varnothing 4.0mm 24k Bullets, Pre-Soldered and Shrink Wrap

www.KDEdirect.com
KDEDirect
www.KDEdirect.com
KDE6213XF-185