

**KDE3510XF-715 KDE DIRECT UAS BRUSHLESS MOTOR
PRODUCTION RELEASE**

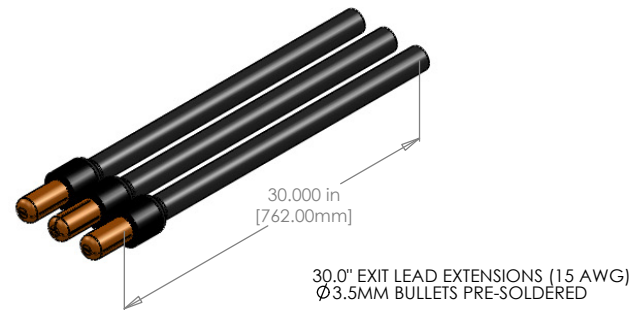
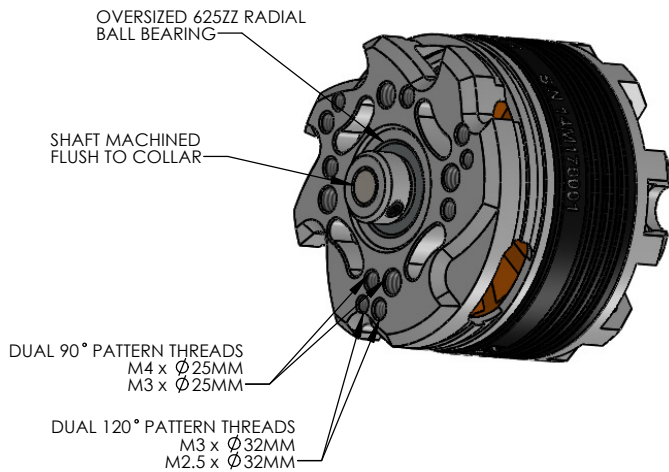
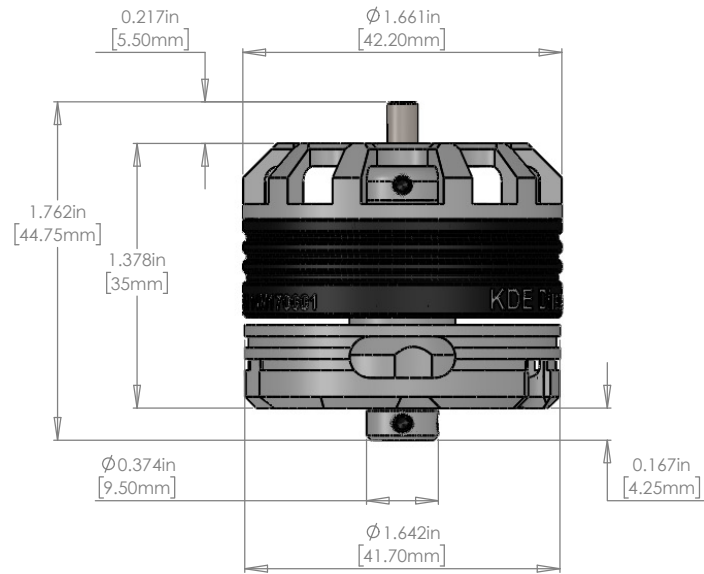
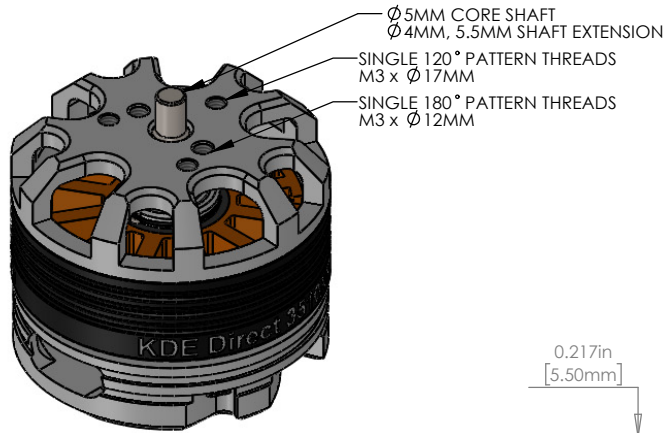

KDE DIRECT UAS BRUSHLESS MOTOR SPECS.

ϕ 5mm Core Shaft
 ϕ 4mm, 5.5mm Extended Length
 - Shaft Flush with Retaining Collar

MR105ZZ Upper Bearing (ϕ 5mm x ϕ 10mm x 4mm)
 - Double Upper Bearings
 625ZZ Lower Bearing (ϕ 5mm x ϕ 16mm x 5mm)

Single 120° Pattern Threads:
 M3 Threads x ϕ 17mm Spacing

Single 180° Pattern Threads:
 M3 Threads x ϕ 12mm Spacing

Dual 90° Pattern Threads:
 M4 Threads x ϕ 25mm Spacing
 M3 Threads x ϕ 25mm Spacing

Dual 120° Pattern Threads:
 M3 Threads x ϕ 32mm Spacing
 M2.5 Threads x ϕ 32mm Spacing

30° Exit Lead Extensions (15 AWG)
 ϕ 3.5mm 24k Bullets, Pre-Soldered and Shrink Wrap

