

**KDE2814XF-515 KDE DIRECT UAS BRUSHLESS MOTOR
PRODUCTION RELEASE**

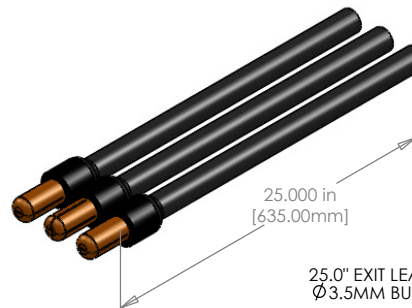
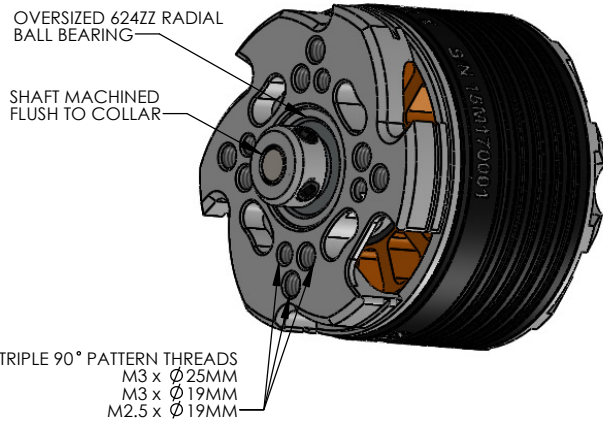
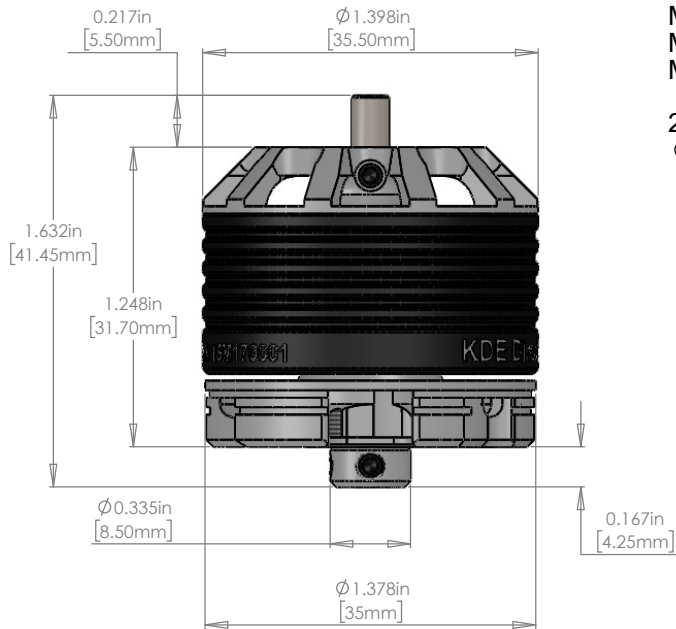
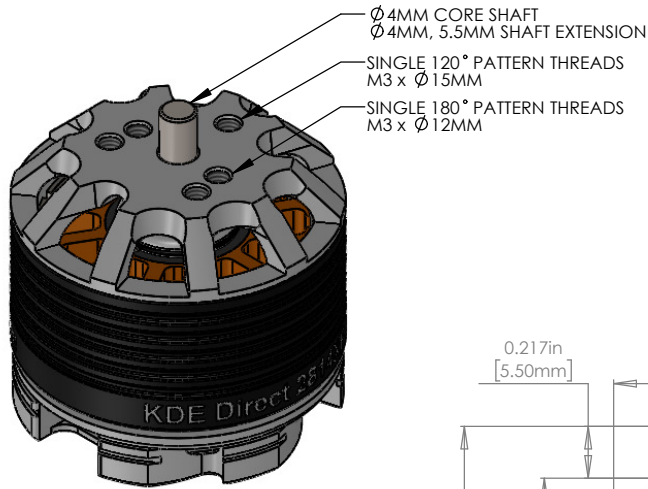

25.0" EXIT LEAD EXTENSIONS (17 AWG)
 \varnothing 3.5MM BULLETS PRE-SOLDERED

KDE DIRECT UAS BRUSHLESS MOTOR SPECS.

\varnothing 4mm Core Shaft
 \varnothing 4mm, 5.5mm Extended Length
 - Shaft Flush with Retaining Collar

684ZZ Upper Bearing (\varnothing 4mm x \varnothing 9mm x 4mm)
 - Double Upper Bearings
 624ZZ Lower Bearing (\varnothing 4mm x \varnothing 13mm x 5mm)

Single 120° Pattern Threads:
 M3 Threads x \varnothing 15mm Spacing

Single 180° Pattern Threads:
 M3 Threads x \varnothing 12mm Spacing

Triple 90° Pattern Threads:
 M3 Threads x \varnothing 25mm Spacing
 M3 Threads x \varnothing 19mm Spacing
 M2.5 Threads x \varnothing 19mm Spacing

25" Exit Lead Extensions (17 AWG)
 \varnothing 3.5mm 24k Bullets, Pre-Soldered and Shrink Wrap

