

**KDE2315XF-2050 KDE DIRECT UAS BRUSHLESS MOTOR
PRODUCTION RELEASE**

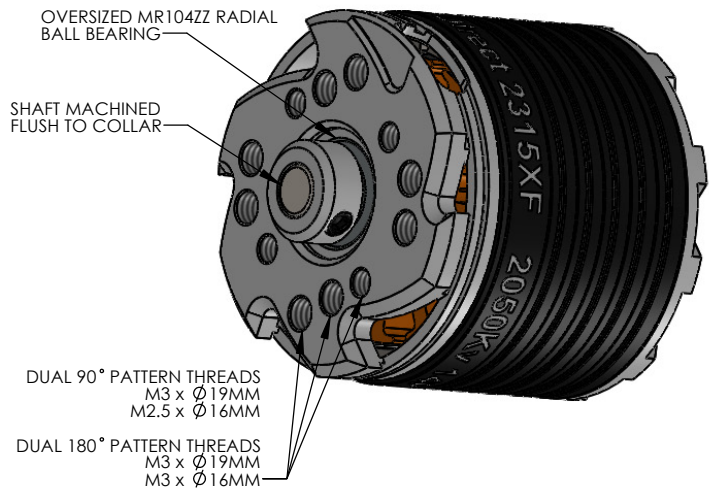
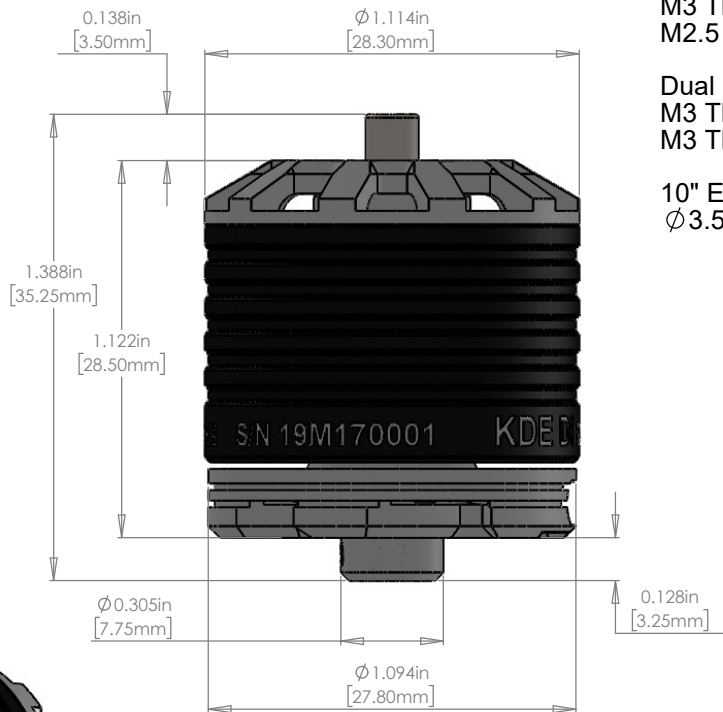
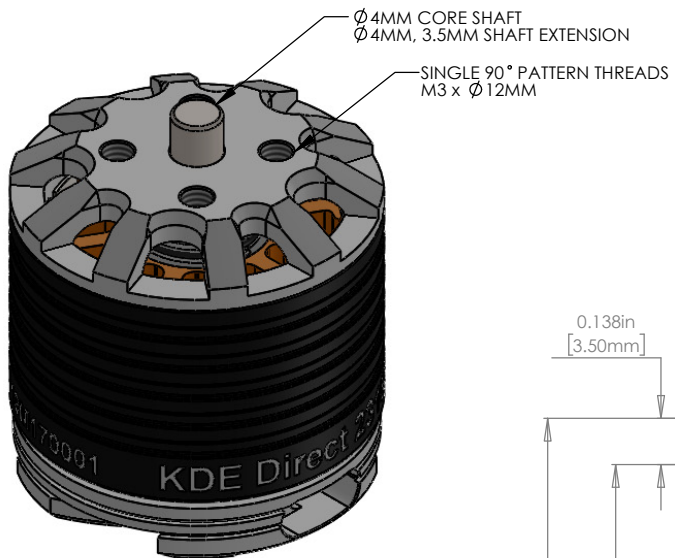

KDE DIRECT UAS BRUSHLESS MOTOR SPECS.

ϕ 4mm Core Shaft
 ϕ 4mm, 3.5mm Extended Length
 - Shaft Flush with Retaining Collar

MR84ZZ Upper Bearing (ϕ 4mm x ϕ 8mm x 3mm)
 - Double Upper Bearings
 MR104ZZ Lower Bearing (ϕ 4mm x ϕ 10mm x 4mm)

Single 90° Pattern Threads:
 M3 Threads x ϕ 12mm Spacing

Dual 90° Pattern Threads:
 M3 Threads x ϕ 19mm Spacing
 M2.5 Threads x ϕ 16mm Spacing

Dual 180° Pattern Threads:
 M3 Threads x ϕ 19mm Spacing
 M3 Threads x ϕ 16mm Spacing

10" Exit Lead Extensions (18 AWG)
 ϕ 3.5mm 24k Bullets, Pre-Soldered and Shrink Wrap

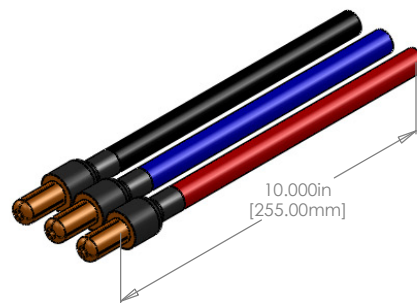

10.0" EXIT LEAD EXTENSIONS (18 AWG)
 ϕ 3.5MM BULLETS PRE-SOLDERED

BLACK/BLUE/RED LEADS
 ROTATION-DIRECTION MATCHED (CW)



www.KDEDirect.com
KDE2315XF-2050