

**KDE2306XF-2050 KDE DIRECT UAS BRUSHLESS MOTOR
PRODUCTION RELEASE**

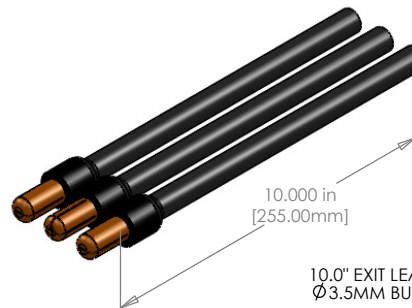
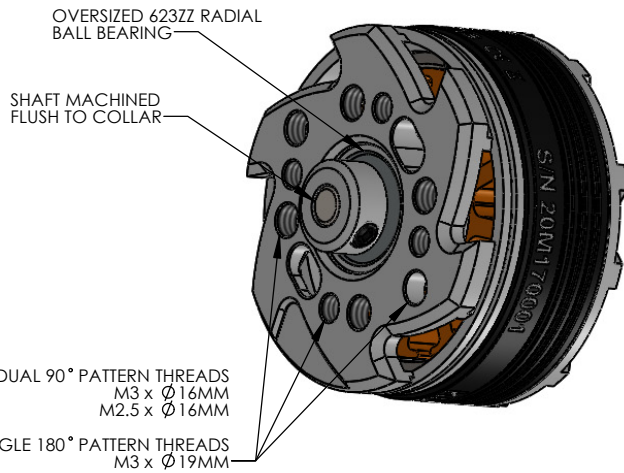
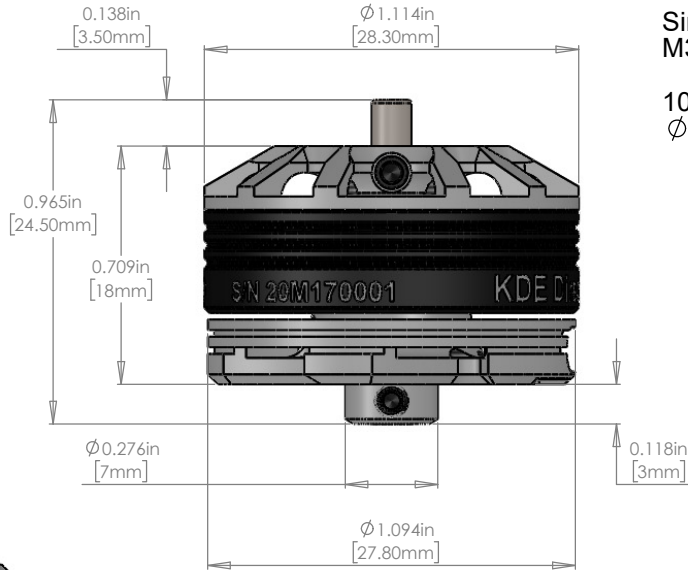
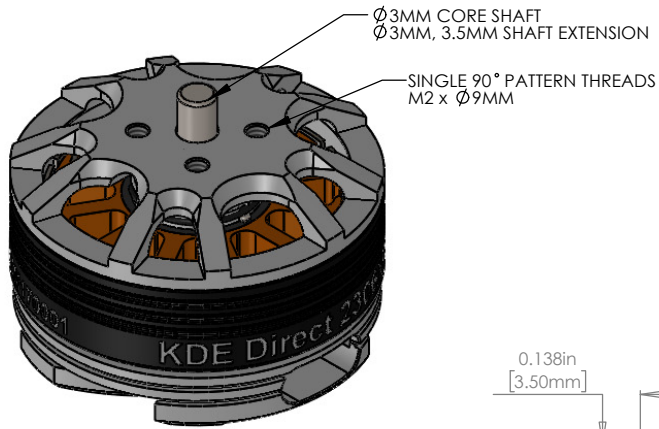

KDE DIRECT UAS BRUSHLESS MOTOR SPECS.

Ø3mm Core Shaft
Ø3mm, 3.5mm Extended Length
- Shaft Flush with Retaining Collar

693ZZ Upper Bearing (Ø3mm x Ø8mm x 4mm)
623ZZ Lower Bearing (Ø3mm x Ø10mm x 4mm)

Single 90° Pattern Threads:
M2 Threads x Ø9mm Spacing

Dual 90° Pattern Threads:
M3 Threads x Ø16mm Spacing
M2.5 Threads x Ø16mm Spacing

Single 180° Pattern Threads:
M3 Threads x Ø19mm Spacing

10" Exit Lead Extensions (19 AWG)
Ø3.5mm 24k Bullets, Pre-Soldered and Shrink Wrap

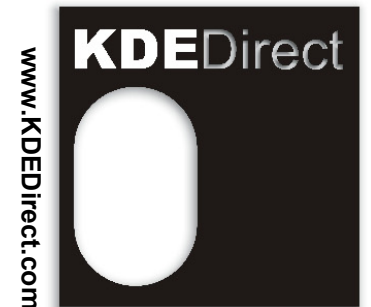

www.KDEDirect.com

www.KDEDirect.com
KDE2306XF-2050