

# Oliveri

VITREOUS CHINA

Wall Faced Toilet Suite

Installation instructions for Wall Faced Toilet Suite

THIS TOILET MUST BE INSTALLED BY A LICENSED PLUMBER IN ACCORDANCE WITH LOCAL REGULATIONS

This Oliveri toilet suite is manufactured to Australian standard AS 1172.1 & AS 1172.2

### Remove all products from packaging:

Check the product for damage, if the product is damaged return to store of purchase. Check the product is complete with all components required to install. This product is to only be installed by a licensed plumber, failing to do so will void warranty. This product is to be installed as per Australian Standard and local authority requirements.

**WARNING: DO NOT BED THE PAN IN PLACE USING CEMENT, CONCRETE OR SIMILAR MATERIAL, DOING SO WILL VOID THE PRODUCT WARRANTY.**

**N.B Refer to Geberit Sigma 8 in-wall cistern installation instruction sheets when using this installation document to ensure the Wall Faced toilet suite is installed correctly.**

### Cistern Installation:

Refer Geberit Sigma 8 installation instruction sheet in conjunction with the dimensional pan drawings on this document for correct installation.

1. Mark the centre line of the Pan connector on the floor for "S" trap installation or on the wall for "P" trap installation.
2. Place the pan into position centralising the pan on your centre line, draw around the pan base and mark the entry points on the floor to where the floor fixing holes are on the side of the pan.
3. Remove the pan and drill and screw into place the floor fixing brackets, set the floor fixing brackets 15mm inside the line drawn around the base of the pan. Use suitable floor fixing screws and toggles to suit the floor material.
4. **Critical:** The pan must be on a level surface square to the wall, if the floor slopes away the pan will need to be levelled using suitable floor chocks around the pan to support and stabilise the pan.
5. The standard variance bend (ZH6200) supplied has a set out of 55mm to 110mm, the optional Variance bend (VT103) has a set out of 150mm to 180mm and is purchased as optional extra.

# Oliveri

## Oslo



Product code: OS127BTW  
VI1273ST

### "S" trap installation

6. Place the variance bend into the floor outlet, from the finished floor to the centre of the pan outlet is 125 mm, ensure the variance bend is straight and square to the wall and centralised to the pan outlet height, assemble the variance bend wall brace and fix to the finished wall. Measure the distance from the back edge of the pan to the "P" trap edge and add on sufficient length for the Variance bend collar to fully engage the "P" trap. Remove the locking ring and rubber boot from the Variance bend. The distance between each ridge on the Variance bend is 10mm. Once the excess has been cut off the variance bend reassemble the rubber boot and locking ring.
7. Slide the pan into place being careful that full engagement of the pan variance bend and cistern flush pipe has been achieved.
  - N.B** pre-soaping the rubber boot on the Variance bend and key seal on the flush pipe will assist with easier engagement.
8. Once the pan is in place and connected to the Variance bend and Flush pipe screw the pan in place using the supplied fixing screws and cover.
9. Assemble the seat using the seat assembly instructions supplied in the seat box.

**DO NOT OVER TIGHTEN SCREWS AS THIS MAY CAUSE THE PAN TO CRACK**

**DO NOT USE OFFSET PAN COLLARS ON S OR P TRAP INSTALLATIONS AS THIS WILL COMPROMISE WASTE DISCHARGE. DOING SO WILL VOID THE PRODUCT WARRANTY.**

**IMPORTANT:**

Sand and debris move through water pipes. Always Flush the line prior to connecting Toilet Suite inlet pipe to Water Control valve.

**CARE & MAINTENANCE**

Avoid using abrasive or acid based cleaning products.

**WARRANTY:**

This Toilet Suite is warranted to be free from manufacturing defects for a period of:

10 Years vitreous china

2 Years, seat.

1 Year, seals and labour.

Geberit In-Wall cisterns are covered by Geberit's warranty

This warranty does not cover against normal wear and will be voided if the product is misused or not installed in accordance with these instructions.

In the event this product is rendered obsolete and a replacement product is required.

Oliveri Solutions Pty Ltd reserves the right to supply a product of equal substitution at their discretion.

Our goods come with guarantees that cannot be excluded under the Australian Consumer Law. You are entitled to a replacement or refund for a major failure and for compensation for any other reasonably foreseeable loss or damage. You are also entitled to have the goods repaired or replaced if the goods fail to be acceptable quality and the failure does not amount to a major failure.

**SERVICE**

If the problem represents a danger, or damage to property may occur, immediately shut off the water supply.

If the toilet requires servicing, please contact your installer (preferably the one who installed it).

If the installer is satisfied that the problem is not due to poor installation, contact T2 Services Pty Ltd for assistances on:

**Ph :( 07) 55960738**

**Fax :( 07) 55273353**

**Email:oliveri@t2services.com.au**

**https://oliveri.com.au/service-and-warranty**

If the warranty service agent finds that the toilet is not faulty, T2 Services Pty Ltd reserves right to pass on any callout fee to the householder.

**SET OUT DRAWING**

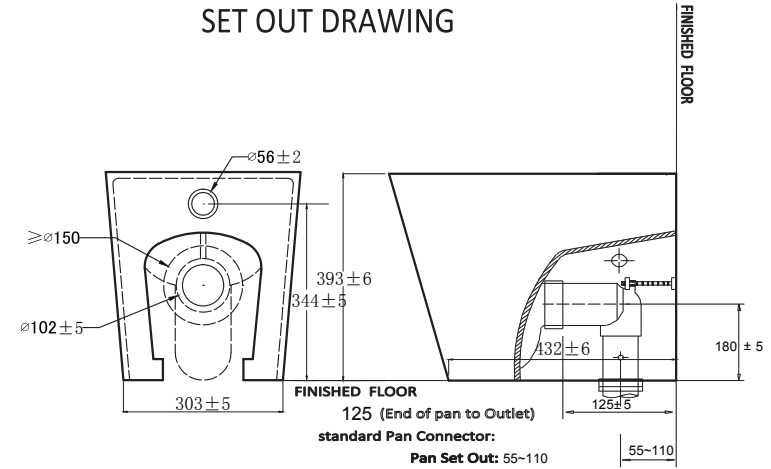

**OPTIONAL SET OUT**

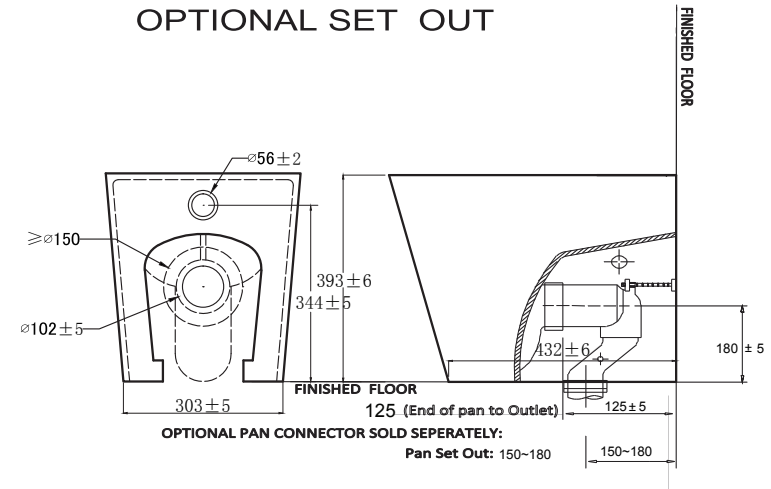

UNIT:MM