

VERTEX PRO DIAMOND/4

PRODUCT ASSEMBLY INSTRUCTIONS

DESKHAUS//



⚠ WARNING

Read all instructions and review all illustrations before installing. Failure to observe these warnings could result in a fire or electrical shock. Use two or more people when moving products or personal injury may result. Ensure there are no obstacles in unit's path and that it is clear of walls during movement. Cords must be appropriate length to accommodate change in height. Keep children away from height adjustable base. Keep electrical components away from liquids. Do not sit or stand on base or work surface. Do not open any components. Designed for a 10% duty cycle, two minutes on and eighteen minutes off. In the event of a power outage, or if the power cord is unplugged, a reset is required.

NOTES

VERTEX PRO DIAMOND/4

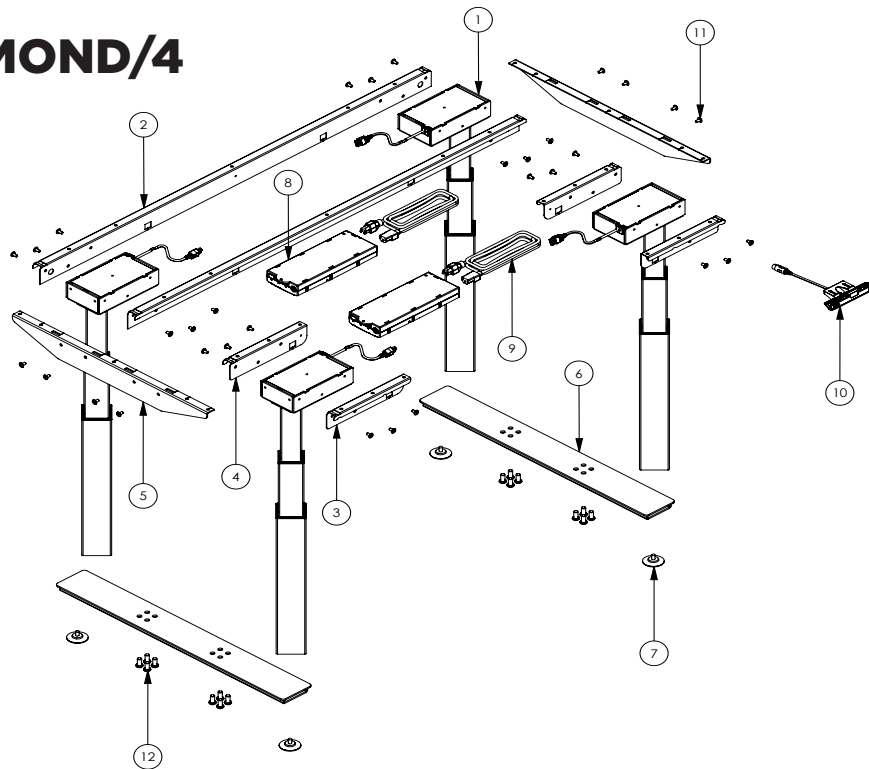

PARTS

PARTS	QTY
1. Column	4
2. J-Rail	2
3-4. Mini-J-Rail	4
5. Top Support	2
6. Foot	2
7. Feet pads	4
8. Control box	2
9. Power Cord	2
10. Hand switch	1
11. M6x1.0 12mm Screw	32
12. M10x1.5 20 mm Screw	16

FASTENERS INCLUDED:



TOOLS NEEDED:

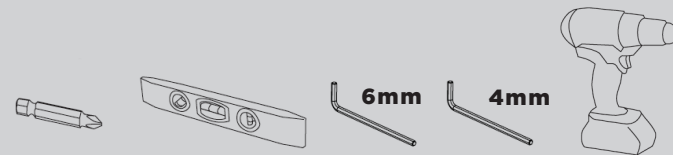

1

ASSEMBLE COLUMNS TO J-RAILS

Assemble using the M6x1.0 12mm length screws. These are the **shorter screws** that are included. (6 per column)

PARTS

Column
J-Rail
Mini-J-Rail
M6x1.0 12mm Screw

QTY

4
2
4
24

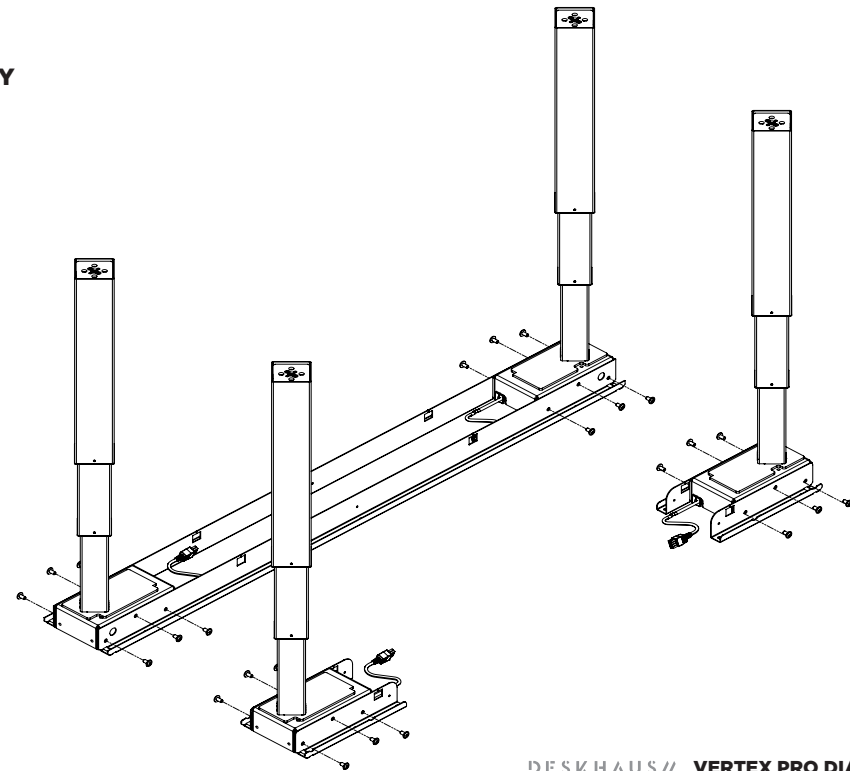

2

ASSEMBLE TOP SUPPORTS TO COLUMNS

Assemble using the M6x1.0 12mm length screws.
These are the **shorter screws** that are included.
(4 per top support)

PARTS

Top Supports
M6x1.0 12mm Screw

QTY

2
8

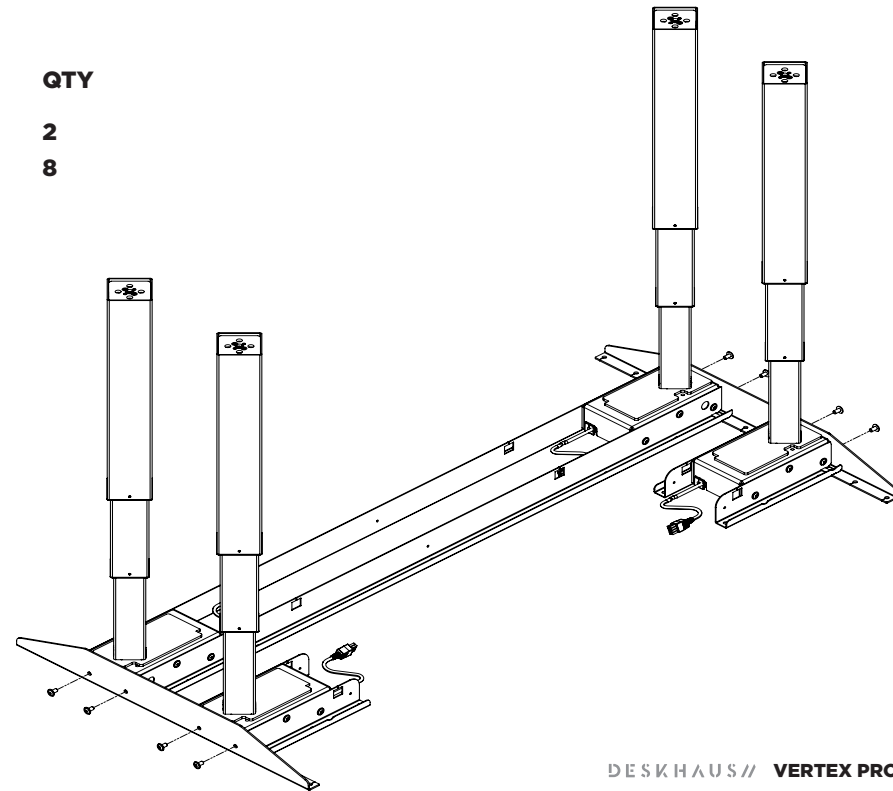

3

ASSEMBLE FEET TO COLUMNS

Assemble using the M10x1.5 20mm length screws.
These are the **longer screws** that are included.
(4 per column)

PARTS	QTY
Foot	2
M10x1.5 20mm Screw	16

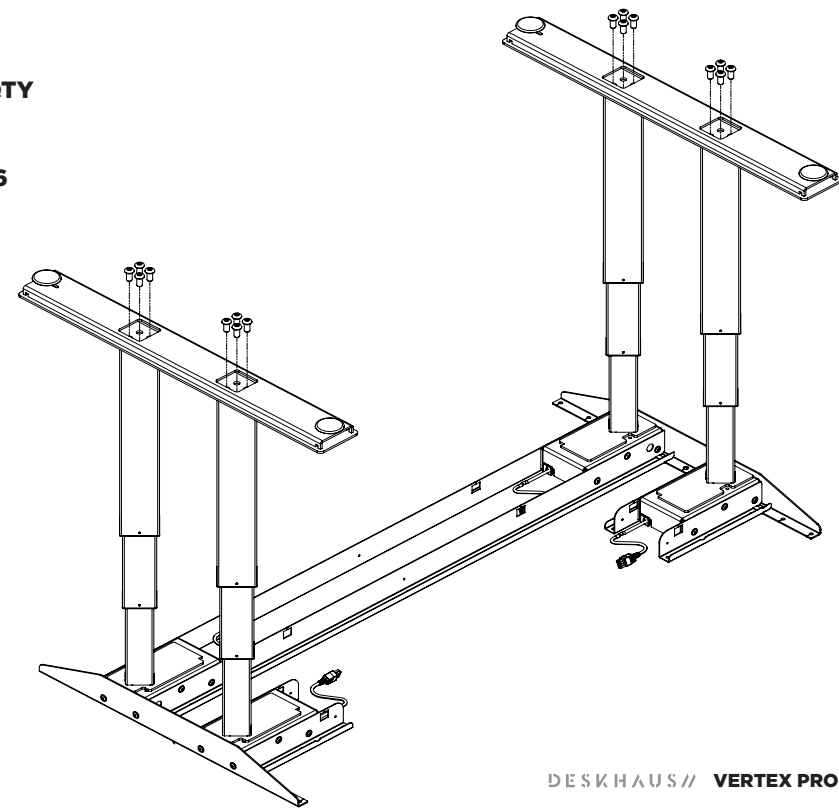

4

FASTEN FRAME TO DESK SURFACE

Assemble using the 7/8" length wood screws.
(30 per frame)

PARTS

#10 7/8" Wood Screw

QTY

30

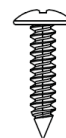

X30

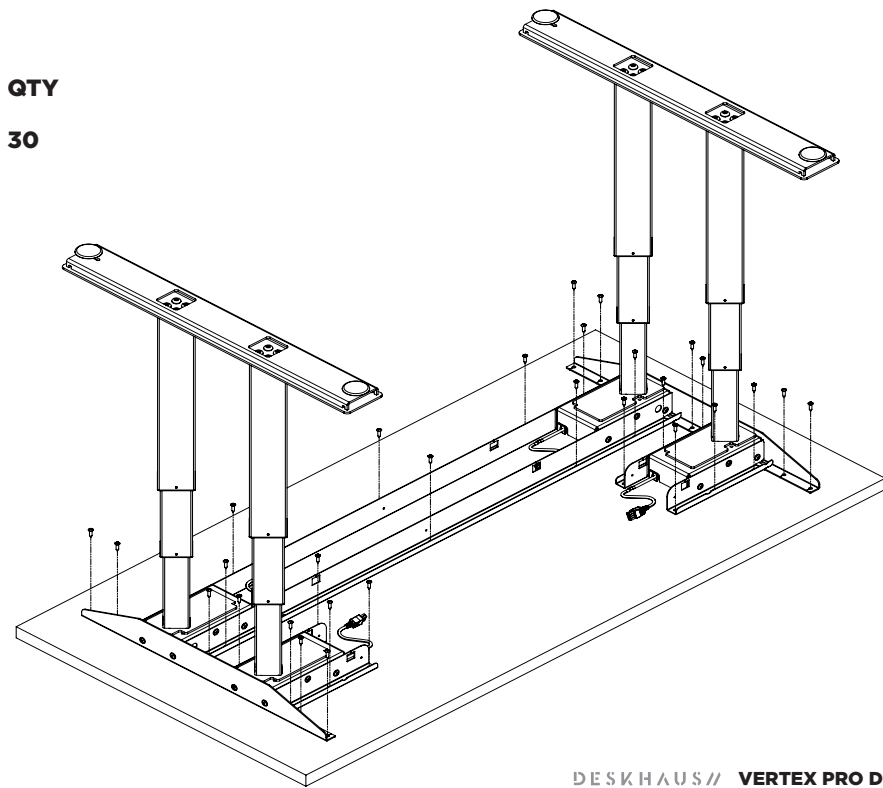

5

FASTEN CONTROL BOX AND HAND SWITCH TO DESK SURFACE

Assemble using the 7/8" length wood screws.

Make sure the control box and hand switch are fastened in a location where all the cables will connect without being in tension.

PARTS

Control Box

QTY

2

Hand switch

1

#10 7/8" Wood Screw

6

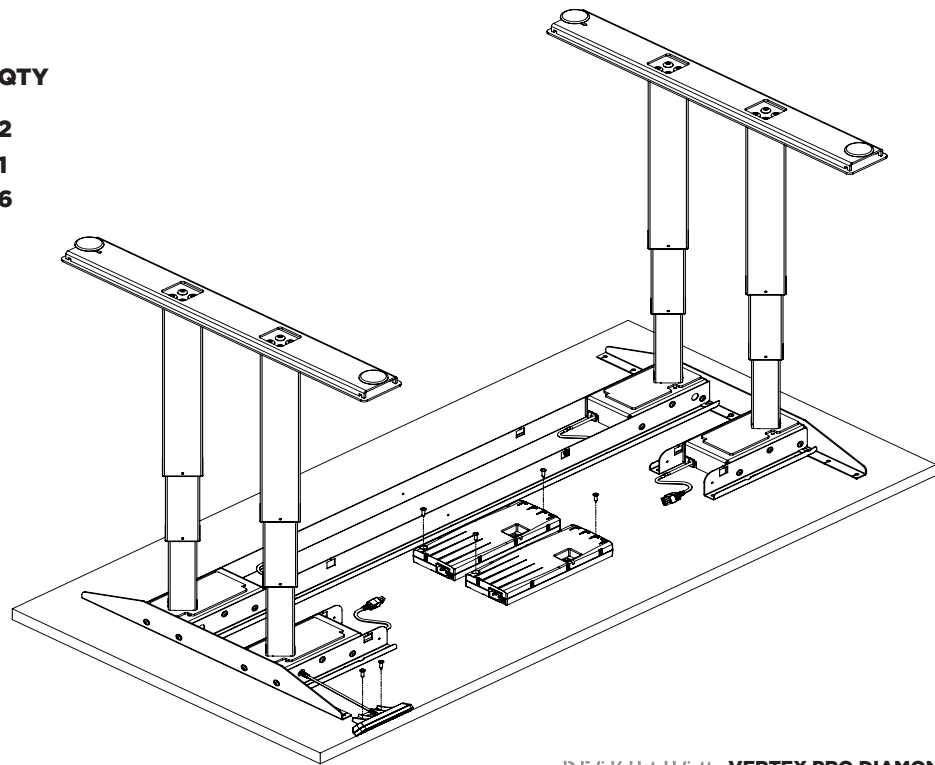



**STOP.
VERY IMPORTANT.**

**PAY CLOSE ATTENTION
TO THIS NEXT STEP.
SERIOUSLY.**

CASCADING CONTROL BOXES



ATTENTION!!

Do **NOT** plug the power cords into the control boxes until you read these important instructions.

1. Plug in everything **EXCEPT** the power cords into the control boxes or the outlet.
 - a. This includes the columns to the control boxes, the jumper cable to connect the two control boxes, and the hand switch into one of the control boxes.
2. After this is done you **MUST** plug the power cord into the control box that has the hand switch plugged into it first, and then plug the other end of this same power cord into the outlet. (You will hear a clicking sound from the control box.)
3. Next, plug the power cord for the other control box into the control box and then into the outlet. (You will hear a clicking sound from this control box)
4. At this point all of the columns should have power to them. Press and hold **DOWN** on the hand switch to initialize the columns as a group. (You should see the columns move slightly.)
5. Your columns are now ready for normal operation.

6

CONNECT CABLES TO CONTROL BOX

Make sure the control box and hand switch are fastened in a location where all the cables will connect without being in tension.

- Plug in power cord last.

NOTE: SECURE ALL CABLES TO TABLE FRAME OR UNDERSIDE OF SURFACE TO AVOID DAMAGE DURING OPERATION.

CASCADING CONTROL BOXES



PAY CLOSE ATTENTION

THESE STEPS NEED TO HAPPEN IN THIS SPECIFIC ORDER.
WE CAN NOT BE RESPONSIBLE FOR CONTROL BOX DAMAGE
IF USER MAKES IMPROPER CONNECTIONS.

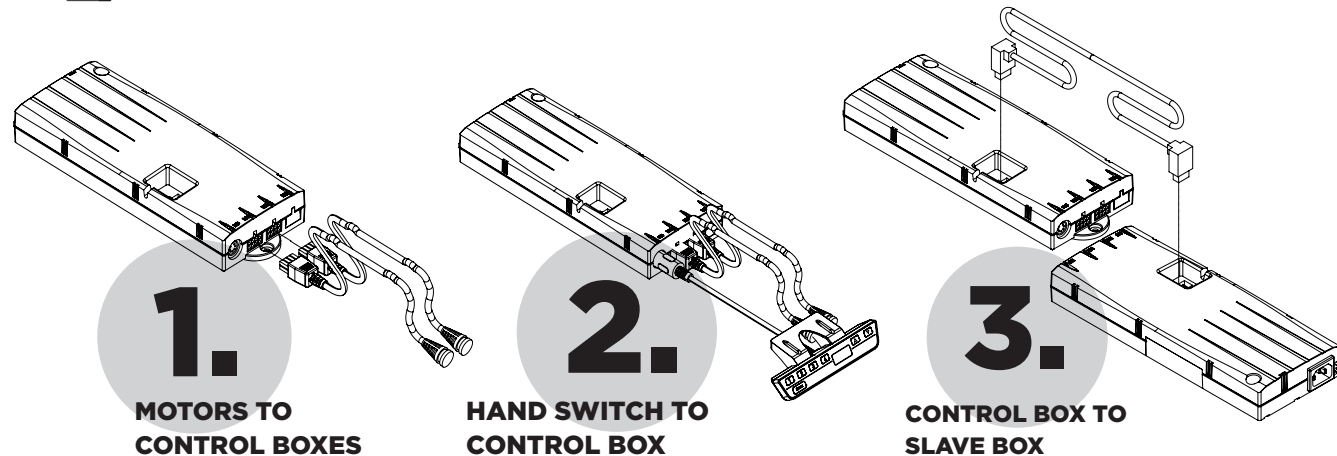

CASCADING CONTROL BOXES CONTINUED



PAY CLOSE ATTENTION

THESE STEPS NEED TO HAPPEN IN THIS SPECIFIC ORDER.
WE CAN NOT BE RESPONSIBLE FOR CONTROL BOX DAMAGE
IF USER MAKES IMPROPER CONNECTIONS.

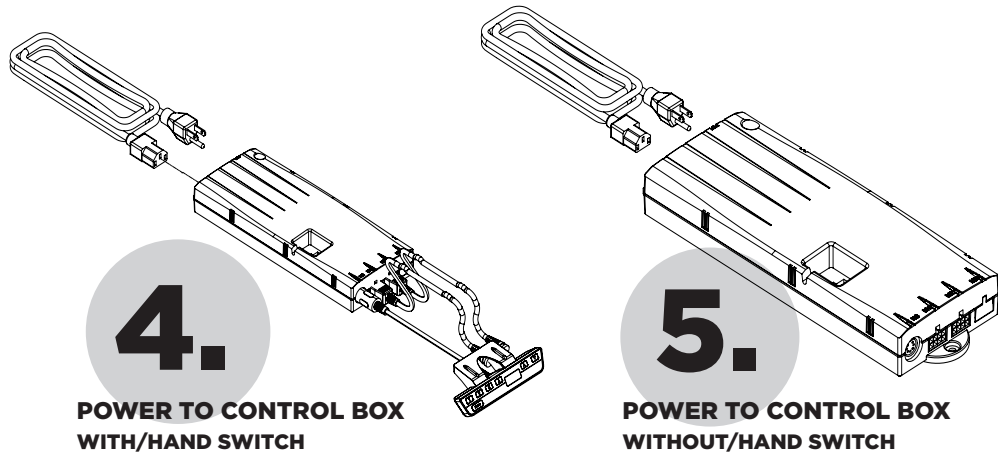

Troubleshooting

If you are having trouble please try the following steps.

1. Unplug **EVERYTHING** except the power cable from one outlet to the control box with the hand switch plugged into it as well.
2. Press and hold the 1 & 2 Buttons as well as the Up Arrow. Hold these three buttons until the display reads Once you see this on the display, press the Up Arrow until the display reads Then press the green "S" button. After hearing clicking from the control box unplug **EVERYTHING** from the control box.
 - a. Remove the Hand Switch and repeat the previous steps for the 2nd Control Box.
3. After both columns are reset, you can follow the original steps 1-5.

OPERATION INFORMATION

INITIALIZATION/RESET

The desk must be initialized/reset after any of the following:

- After assembly
- After disconnection from the power supply
- After any impact on the table top.

To initialize/reset, move the table to the lowest position by pressing the DOWN button on the hand switch until the columns reach the lowest position. Press the DOWN button again until the table moves slightly down to the machine zero point and back up to the operation zero point. Release the DOWN button. If the button is released too soon, the table legs will not move up. Repeat the reset process.

The control box is programmed with a parameter file which controls the table legs' lower and upper travel limits. **Under no circumstance should a control box from one table be moved to another.**

NORMAL HAND SWITCH OPERATION (for all hand switch types)

By pressing the UP or DOWN buttons, the table will move up or down to the desired position. Once the desired position is reached, let go of the UP or DOWN button. The table legs will stop once they reach the lower or upper height limits.

PROGRAMMABLE HAND SWITCH OPERATION (optional)

This programmable hand switch is equipped with a display for showing the current table height in centimeters or inches.

The hand switch also will display an error code if an error is detected by the control box. When an error is detected, the display will show an error code "EXX," instead of the current table height. To resolve the error, see the Troubleshooting Section (p. 16-17 of this guide).

The programmable hand switch also has the ability to save up to four different height positions.

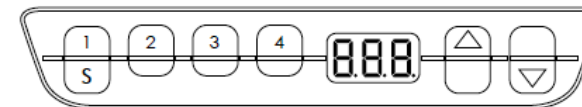

PROGRAMMABLE HAND SWITCH OPERATION (continued)

CHANGE THE HEIGHT UNIT (inches or centimeters)

The hand switch can display the table height in either centimeters or inches. With the help of the S5-menus, the unit of measure can be changed.

To change the unit of measure, follow these steps:

- 1.** Press and hold the 1, 2, and UP buttons until the display shows “S 5”.
- 2.** Confirm by pressing the “S” button. Now the display will have changed.

To exit the menu without making a selection, wait until the height display appears again.

CHANGE THE HEIGHT DISPLAY

If the displayed value does not match the actual height of the table top, the display can be corrected as follows:

- 1.** Press and release the “S” button.
- 2.** Press and hold the DOWN button until the display starts to flash.
- 3.** Change the height shown on the hand switch by pressing the UP or DOWN button to the desired height.

Confirm by pressing the “S” button.

To exit the menu without making a selection, wait until the height display appears again.

SAVE MEMORY POSITION

- 1.** Move the table up or down to the desired height.
- 2.** Press the “S” button (in the display “S -” is shown.)
- 3.** Select a position by pressing one of the four number buttons, 1-4, (if 1 is selected, the display will show the setting as “S1”).
- 4.** The saved position is confirmed by a double click sound from the control box. The display shows the current table height. Repeat steps to save a maximum of four different positions.

RECALL MEMORY POSITION

Press and hold the desired memory button (1, 2, 3 or 4) the table moves from the current position into the saved position. The button must be pressed until the position is reached. If the button is released, the table will stop short of the desired height.

TROUBLESHOOTING

PROBLEM	SOURCE	SOLUTION
Table does not move	No power supply	Plug in the power cord or check the connection on the control box
	No connection or a loose connection to the drives	Verify the plug connections of the motor cable to the control box
	No connection or a loose connection to the hand switch	Verify the plug connections of the motor cable to the control box
	Max lifting capacity is exceeded	Reduce the weight or load on the desktop
	Max time limit is exceeded	Control is activated automatically after approx. 9 minutes
	Defective drive	Contact customer service

PROBLEM	SOURCE	SOLUTION
Table does not move	Defective control box	Contact customer service
	Defective hand switch	Replace hand switch
Table moves down at a slow rate	Control box expects new reset	Reset control box
During operation, table moves at a slow rate	Max lifting capacity is exceeded	Reduce weight
Table moves on one side only briefly and then stops	No connection or a loose connection to the drives	Verify the plug connections of the motor cable to the control box and reset the control box
	Defective drive	Contact customer service

TROUBLESHOOTING CONTINUED

ERROR CODE	SOURCE	SOLUTION
HOT	The control box monitors the duty cycle (time-controlled) and its max temp. A value has been exceeded	Wait until the "HOT" display goes out - the table is working properly again
E00	M1-Internal Fault	Unplug and contact customer service
E01	M2-Internal Fault	
E02	M3-Internal Fault	
E12	M1-Defect	Unplug. Correct the external short circuit and/or verify the cable to the drives. Plug cables into the control box and re-run table.
E13	M2-Defect	
E14	M3-Defect	
E24	M1-Over-current	Collision —————> resolve if necessary
E25	M2-Over-current	Max load exceeded —> remove excess load from the table
E26	M3-Over-current	If the problem persists, contact customer service

ERROR CODE	SOURCE	SOLUTION
E36	M1-Not connected	Motor not connected. Check cable / connector to the drive. Reset the table
E37	M2-Not connected	
E38	M3-Not connected	
E48	Over-current drive 1	Collision —————> resolve if necessary
E49	Over-current drive 2	Max load exceeded —> remove excess load from the table
E55	Drive 1 - Synchronization is lost	If necessary, reduce the load on the table
E56	Drive 2 - Synchronization is lost	Reset the table
E60	Collision identified	Option ISP function. Remove source.
E61	Drive replaced	The connection to the drive is interrupted or a new drive is connected. Reset the table.

NOTES

NOTES

DESKHAUS //

WWW.DESK.HAUS