

# Pro-Drive<sup>®</sup> **FASTENERS**

Pro-Driven Industrial Products and Solutions™

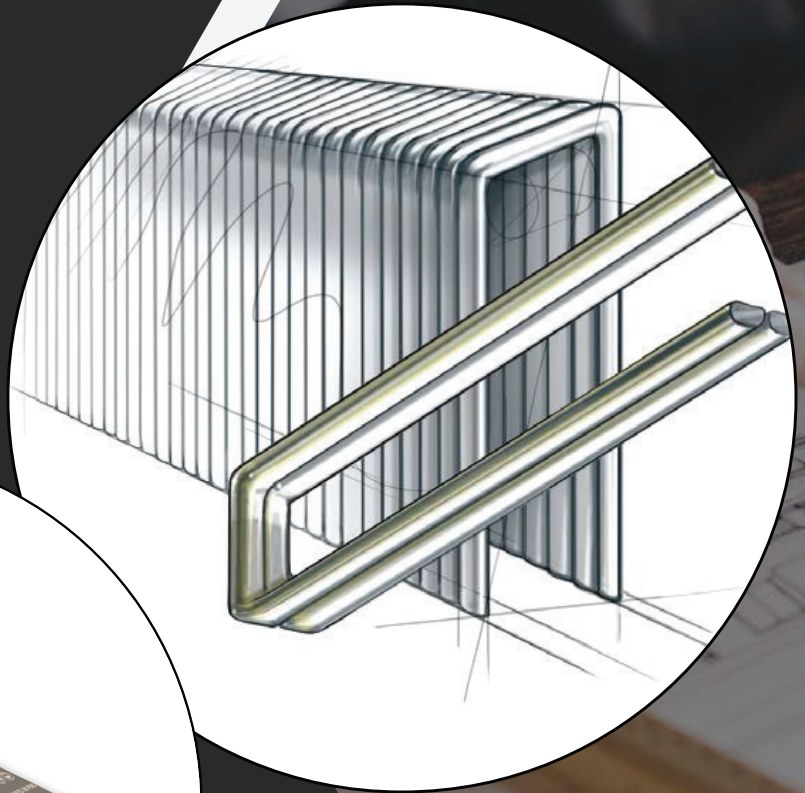

SUPERIOR  
QUALITY  
AT THE  
**RIGHT**  
PRICE



Pro-Driven  
Industrial Products  
and Solutions

**Pro-DriveFasteners.com**





SUPERIOR QUALITY AT THE RIGHT PRICE

## About Pro-Drive Fasteners:

Pro-Drive Fasteners is a premier provider of top-quality products for the flooring industry.

From a one stop line of staples and nails and ever-expanding line of pneumatic tools to our new line of Orbital and Jitterbug sanders. Pro-Drive Fasteners™ is a premier provider of top-quality products for the Wholesale wood distribution channels as well as meeting the requirements with the OEM cabinet/furniture industries.

Product development is a company specialty, as is exceptional quality. In providing products to meet the demands of the industrial environment, Team Pro-Drive Fasteners traces the origins of each process--all the way back to the steel.

Just as we are involved with all aspects of our product, we're similarly committed to all aspects of the customer experience. This includes shipping policies to meet your professional needs. Pro-Drive Fasteners™ offers same-day shipping for orders received by 11am, as well as bulk or full truckload and private label pricing options.

At Pro-Drive Fasteners™, we continue to innovate the fastening market so we can be your one-stop vendor for premium fasteners and assembly solutions!



Learn more at  
[Pro-DriveFasteners.com](http://Pro-DriveFasteners.com)

# TABLE OF CONTENTS

STAPLES Medium Crown	pg. 4-6
15 GA 1/2" Crown Flooring Staples	pg. 4
15 GA (Q Wire) 7/16" Crown Staples	pg. 5
16 GA (GS Wire) "Paslode" 1/2" Crown Wire Staples	pg. 6
16 GA (N Wire) 1/2" Crown Staples	pg. 6
STAPLES Wide Crown	pg. 7
16 GA 16 GAUGE (S2 SERIES) Bostitch" 1" Wide Crown Staples	pg. 7
16 GA (P Wire) 1" Crown Wire Staples	pg. 7
STAPLES 18 GA	pg. 8
18 GA (M Wire) 3/8" Crown Staples	
18 GA (L Wire) Duo-Fast 1800 series	
BRADS-FINISH-MICRO Pins	pg. 9-14
15 GA FN 25° Angle Collated strip FINISH Nails	pg. 10
15 GA DA 34° Angle Collated strip FINISH Nails	pg. 11
16 GA 0° No Angle Collated strip BRAD Nails	pg. 12
16 GA 20° Paslode Angle Collated strip BRAD Nails	pg. 12
18 GA 0° Angle Collated strip BRAD nails "Medium HEAD"	pg. 13
23 GA Micro Pins	pg. 14
DIVERGENT STAPLES Manual & Electric	pg. 15
20 GA "PAD/Carpet Staples	pg. 15
19 GA "PAD" Staples	pg. 15
20 GA Stair Tread Carpet Staples	pg. 15
UPHOLSTER- ASSEMBLY Staples	pg. 16
20 GA Staples (80/10 C & 80/12 C)	pg. 16
20 GA Fine Wire Staples (BEA-97/12 & BEA-97/16)	pg. 16
22 GA Staples (BEA7106 & BEA7110)	pg. 17
PNEUMATIC STAPLERS - FINISH TOOLS	pg. 18-19
Brad-Finish - Micro Pin Nailers	pg. 18
Fine Wire - Narrow Crown - Medium Crown - Wide Crown Staplers	pg. 19
MALLETS AND CAPS	pg. 25-32
Urethane Striking Faces	pg. 25
Poly Dead Blow Hammer	pg. 26
Mallet Caps	pg. 27
Mallets	pg. 28
Split Head Hammer Faces	pg. 29
VCAP™ Rubber Mallet Tips	pg. 30
EZ-Connect™ Tapping Block	pg. 31
Hammer Tackers	pg. 32
Tipper-De-Tipper™	pg. 33



# 15.5 GA HARDWOOD FLOORING STAPLES

## FLOORING STAPLES

Guaranteed to fit all standard 15.5 gauge flooring tools.



- DESCRIPTION:**
- Sold in Contractor Bulk Packs and 1,000 count Project Packs.
  - Packed in heavy-duty, FOUR-way, reinforced, resealable boxes.
  - Chisel point staple angle reduces splitting during installation.
  - Excellent for all types of hardwood flooring installations.



LENGTH: **2"** (50mm)

FS-200-5000	2"	E-G Galvanized	Chisel Point	5,000	23.8 lbs
FS-200-6000	2"	E-G Galvanized	Chisel Point	1,000 x 6	28.1 lbs
FS-200-7200	2"	E-G Galvanized	Chisel Point	7,720	35.1 lbs

LENGTH: **1-3/4"** (44mm)

FS-175-5000	1-3/4"	E-G Galvanized	Chisel Point	5,000	20.4 lbs
FS-175-9000	1 3/4"	E-G Galvanized	Chisel Point	9,000	36.9 lbs

LENGTH: **1-1/2"** (38mm)

FS-150-5000	1-1/2"	E-G Galvanized	Chisel Point	5,000	18.2 lbs
FS-10300-150	1 1/2"	E-G Galvanized	Chisel Point	10,300	36.9 lbs



Learn more at  
[Pro-DriveFasteners.com](http://Pro-DriveFasteners.com)

Electro Galvanized steel provides a very thin layer of coating with a measure of protection against the elements. Over time these nails may corrode. Not recommended for exterior application or ACO Treated Lumber. WARNING: This product can expose you to chemicals including Nickel and Lead which are known to the State of California to cause cancer. For more information visit: [www.P65Warnings.ca.gov](http://www.P65Warnings.ca.gov)





# 15 GA STAPLES

## 7/16" CROWN (Q WIRE) STAPLES

### Senco Style Staples



- DESCRIPTION:**
- Collation: Straight Strip
  - Crown: 7/16"
  - Gauge: 15
  - Meets or Exceeds ASTM A641

Verify Compatibility by Consulting Owner Manual

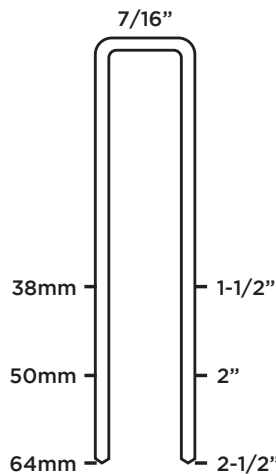

Q17	1 1/2"	E-G Galvanized	Chisel Point	5,000	18.7 lbs
Q21	2"	E-G Galvanized	Chisel Point	5,000	23.1 lbs
Q25	2 1/2"	E-G Galvanized	Chisel Point	5,000	29.7 lbs

#### Guaranteed to work with:

Senco SQS55, FASCO F45C SQ-55 SS(CT), F5 SQ-65 CT, SQS55XP; Spotnails: MS6564; Duo-Fast: MS-1580D

#### Precision engineered to interchange:

BeA 180, Duo Fast 1500, Senco Q Wire, Spotnail

This product is made and sold by Pro-Drive Fasteners® and has no relationship with any of the other companies whose trademarks or item numbers are mentioned above.



Learn more at  
[Pro-DriveFasteners.com](http://Pro-DriveFasteners.com)

Electro Galvanized steel provides a very thin layer of coating with a measure of protection against the elements. Over time these nails may corrode.

Not recommended for exterior application or ACO Treated Lumber.

⚠ WARNING: This product can expose you to chemicals including Nickel and Lead which are known to the State of California to cause cancer.

For more information visit: [www.P65Warnings.ca.gov](http://www.P65Warnings.ca.gov)



# 16 GA STAPLES

1/2" CROWN GS (PASLODE WIRE)

7/16" CROWN SENCO STAPLE (N WIRE) STAPLES



- DESCRIPTION:**
- Furniture Frames
  - Cabinet Sub-Assembly
  - Millwork - Door Jambs etc.
  - Heavy Duty Pallet Manufacturing and Repair
  - Heavy Duty Crate Framing
  - Meets or Exceeds ASTM A641

Verify Compatibility by Consulting Owner Manual

## 16 GA 1/2" CROWN GS (PASLODE WIRE) STAPLES

GS16112	1 1/2"	E-G Galvanized	Chisel Point	10,000	26.2 lbs
---------	--------	----------------	--------------	--------	----------



## 16 GA 7/16" CROWN SENCO STAPLE (N WIRE) STAPLES

MC750-N11	3/4"	E-G Galvanized	Chisel Point	15,000	21.0 lbs
MC875-N12	7/8"	E-G Galvanized	Chisel Point	15,000	21.5 lbs
MC100-N13	1"	E-G Galvanized	Chisel Point	12,000	21.3 lbs
MC125-N15	1 1/4"	E-G Galvanized	Chisel Point	10,000	22.0 lbs
MC150-N17	1 1/2"	E-G Galvanized	Chisel Point	10,000	25.3 lbs
MC200-N21	2"	E-G Galvanized	Chisel Point	10,000	34.0 lbs

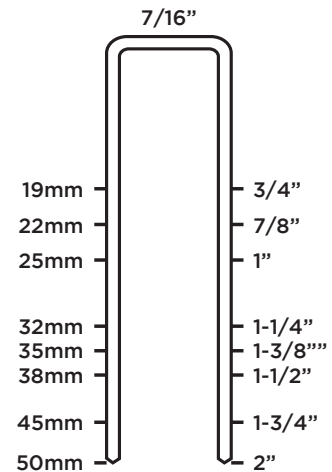

### Guaranteed to work with:

DeWalt D51431; Fasco R3C HD-40 VIL-SID, F45C GC/16-SS  
 Paslode IM200-S16, S200-S16, MA-S16L, 3200-S16, 3200-S16P, 3150-S16, PA-200; Spot-nails X1S1640, MS76-8650i

### Precision engineered to interchange:

Paslode GS-16, and Prebena GX series staples.

This product is made and sold by Pro-Drive Fasteners® and has no relationship with any of the other companies whose trademarks or item numbers are mentioned above.



Learn more at  
[Pro-DriveFasteners.com](http://Pro-DriveFasteners.com)

Electro Galvanized steel provides a very thin layer of coating with a measure of protection against the elements. Over time these nails may corrode.

Not recommended for exterior application or ACO Treated Lumber.

⚠️ WARNING: This product can expose you to chemicals including Nickel and Lead which are known to the State of California to cause cancer.

For more information visit: [www.P65Warnings.ca.gov](http://www.P65Warnings.ca.gov)



# WIDE CROWN STAPLES

16 GA S2 SERIES "BOSTITCH" WIDE CROWN

16 GA 1" CROWN (P WIRE DURO-FAST 1700 SERIES)



- DESCRIPTION:**
- Excellent For Lathing, Sheathing, Foam Insulation Board, Attaching Corrugated to Skids, Furniture and Cabinet Frames, and Butt Joints.
  - Steel Chisel

Verify Compatibility by Consulting Owner Manual

## 16 GA S2 SERIES BOSTITCH" WIDE CROWN

P-16S2-16G	5/8"	E-G Galvanized	Chisel Point	10,000	23.3 lbs
------------	------	----------------	--------------	--------	----------

**Guaranteed to work with:**

Bostitch: T40S2-CT, T50S2-1, T35-8, T35-32, 438S2, 438S2R, 450S2R; Fasco: F3C ATW-38 ROOF, F3C ATW-38 ;Omer: WS.38; :Spotnails: X1S1640 1-1/2", X1S1640RFH, X1S1650 2", X1S1664 2- 1/2"

## 16 GA 1" CROWN (P WIRE DURO-FAST 1700 SERIES)

P08	1/2"	E-G Galvanized	Chisel Point	10,000	17.0 lbs
P10	3/4"	E-G Galvanized	Chisel Point	10,000	20.3 lbs
P11	5/8"	E-G Galvanized	Chisel Point	10,000	17.6 lbs
P13	1"	E-G Galvanized	Chisel Point	10,000	24.0 lbs

**Guaranteed to work with:**

BeA 145, Duo-Fast 1700, Fasco ES6, Senco P, Hitachi N3824A, Prebena WS & W, Spot-nails 3600 series staples.

**Precision engineered to interchange:**

Craftsman®: 18307, 18307; Duo-Fast®: RS-1748, KW-1748, SW-1748, RNS-1748I; Fasco®: R3C SNW 38TL, F3C SNW-38R; Grex®: 2638; Hitachi®: N5024A, N3824A; Grip-Rite®: GRTS1200; Makita®: AT2550A; Omer®: WP.38; Prebena WS & W ;:Spot-nails®: X1S3640(LM) 1-1/2", X1S3650 2", X1S3640RFH; Senco®: MW, MWXP-1, PW, PW-2", PW-R, PW200, SPS, SPS-RFR, PW150/R; WC150XP, WC200XP



This product is made and sold by Pro-Drive Fasteners® and has no relationship with any of the other companies whose trademarks or item numbers are mentioned above.



Learn more at  
[Pro-DriveFasteners.com](http://Pro-DriveFasteners.com)

Electro Galvanized steel provides a very thin layer of coating with a measure of protection against the elements. Over time these nails may corrode.

Not recommended for exterior application or ACO Treated Lumber.

WARNING: This product can expose you to chemicals including Nickel and Lead which are known to the State of California to cause cancer.



For more information visit: [www.P65Warnings.ca.gov](http://www.P65Warnings.ca.gov)



# 18 GA STAPLES

## 3/8" CROWN (M WIRE)

### DUO-FAST 1800 SERIES



- DESCRIPTION:**
- Made from Extra Hard Wire
  - Meets or Exceeds ASTM A641

Verify Compatibility by Consulting Owner Manual

### 18 GA 3/8" CROWN (M WIRE & DUO-FAST 1700 SERIES)

M10BAB58	5/8"	E-G Galvanized	Chisel Point	5,000 x 10 50,000	36.5 lbs
M11BAB34	3/4"	E-G Galvanized	Chisel Point	5,000 x 10 50,000	43.7 lbs
M12BAB78	7/8"	E-G Galvanized	Chisel Point	5,000 x 10 50,000	23.1 lbs
M13BAB100	1"	E-G Galvanized	Chisel Point	5,000 x 10 50,000	56.4 lbs
M15BAB125	1 1/4"	E-G Galvanized	Chisel Point	5,000 x 8 40,000	55.3 lbs

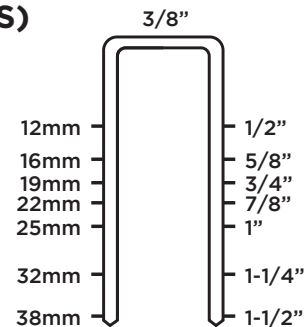

**Applications:**

Cabinet assembly insulation, plastic sheeting, Tyvek, roofing paper, house wrap and more

**Precision engineered to interchange:**

DUO-FAST®W-1800, , JOSEF KIHLEBERG® G4450 , PREBENA® G , SENCO® M, SPOTNAILS® 6800, AND OTHER 3/8" CROWN M WIRE TOOLS. *Not compatible with Arrow T50 series 3/8" crown staplers. May not operate in an automated setup.*

### 18 GA 1/4" CROWN (L WIRE - DUO-FAST 1800 SERIES)

1824-L11	3/4"	E-G Galvanized	Chisel Point	5,000 x 8 40,000	37.8 lbs
1828-L12	7/8"	E-G Galvanized	Chisel Point	5,000 x 8 40,000	42.0 lbs
1832-L13	1"	E-G Galvanized	Chisel Point	5,000 x 8 40,000	46.8 lbs
1836-L14	1 1/8"	E-G Galvanized	Chisel Point	5,000 x 8 40,000	46.8 lbs
1840-L15	1 1/4"	E-G Galvanized	Chisel Point	5,000 x 8 40,000	53.2 lbs
1848-L17	1-1/2"	E-G Galvanized	Chisel Point	5,000 x 8 40,000	62.7 lbs

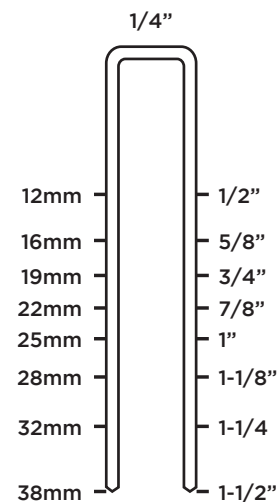

**Applications:**

Finish and trim staples are ideal for cabinets, drawers, case backs, upholstery, soffits, underlayment, lattice, insulation sheathing, Engineering flooring and much more

**Precision engineered to interchange:**

ATRO 90, BeA 90, DUO-FAST 1800, PREBENA EB, HAUBOLD KL 6000 ,HITACHI N3804, PORTER CABLE NS 100 & NS150A , SENCO L, SPOTNAILS 4800, JK 781

This product is made and sold by Pro-Drive Fasteners® and has no relationship with any of the other companies whose trademarks or item numbers are mentioned above.

Electro Galvanized steel provides a very thin layer of coating with a measure of protection against the elements. Over time these nails may corrode.

Not recommended for exterior application or ACO Treated Lumber.

To ensure maximum protection, use Stainless Steel type 316 staples.

**⚠ WARNING:** This product can expose you to chemicals including Nickel and Lead which are known to the State of California to cause cancer.

For more information visit: [www.P65Warnings.ca.gov](http://www.P65Warnings.ca.gov)



Learn more at  
[Pro-DriveFasteners.com](http://Pro-DriveFasteners.com)



# WE HAVE THE RIGHT BRAD/FINISH NAIL FOR ANY JOB!



## 15 GAUGE FINISH NAILS

Commonly used for all types of trim.

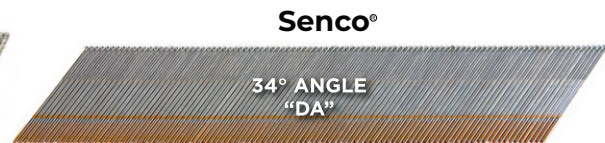

## 16 GAUGE FINISH NAILS

Commonly used for all types of trim.  
Fits all brands.



## 18 GAUGE FINISH NAILS

Used for finer, thinner wood trim. Less putty needed.  
Fits all brands.



## 23 GAUGE FINISH NAILS

Micro Pins fasten with a nearly invisible hole.  
Excellent for face nailing wide plank engineered flooring.



This product is made and sold by Pro-Drive Fasteners® and has no relationship with any of the other companies whose trademarks or item numbers are mentioned above.

Electro Galvanized steel provides a very thin layer of coating with a measure of protection against the elements. Over time these nails may corrode.

Not recommended for exterior application or ACO Treated Lumber.

⚠️ **WARNING:** This product can expose you to chemicals including Nickel and Lead which are known to the State of California to cause cancer.

For more information visit: [www.P65Warnings.ca.gov](http://www.P65Warnings.ca.gov)



Learn more at  
[Pro-DriveFasteners.com](http://Pro-DriveFasteners.com)





# 15 GA "FN" FINISH NAILS

## 25° ANGLE BRAD

Our brad finish nails are professional grade quality, contractor-tested and approved.

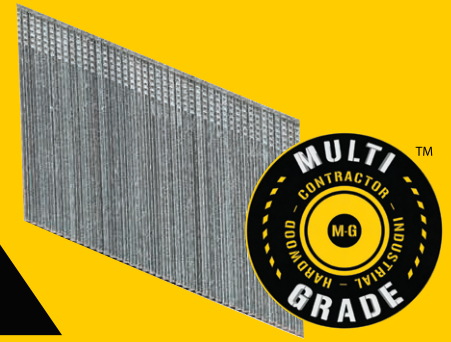

- DESCRIPTION:**
- Chisel Point - Smooth Shank.
  - Electro Galvanized Steel - Meets ASTM F1667.
  - Contractor Packed - 3,655 per box.
  - Made with Premium Grade Steel to Provide Exceptional Performance.
  - Guaranteed to Deliver Worry-free Performance.
  - Excellent for Interior Finish, Trim Work, Hardwood Flooring, Baseboards, and More!

Verify Compatibility by Consulting Owner Manual



1 1/4" (32mm)	Galvanized	4 x 3,655 Count	ITEM# FN1520-125
1 1/2" (38mm)	Galvanized	4 x 3,655 Count	ITEM# FN1524-150
2" (50mm)	Galvanized	4 x 3,655 Count	ITEM# FN1532-200



Learn more at  
[Pro-DriveFasteners.com](http://Pro-DriveFasteners.com)

Electro Galvanized steel provides a very thin layer of coating with a measure of protection against the elements. Over time these nails may corrode. Not recommended for exterior application or ACO Treated Lumber.

**⚠️ WARNING:** This product can expose you to chemicals including Nickel and Lead which are known to the State of California to cause cancer. For more information visit: [www.P65Warnings.ca.gov](http://www.P65Warnings.ca.gov)



# 15 GA "DA" FINISH NAILS

## 34° ANGLE BRAD

Our brad finish nails are professional grade quality, contractor-tested and approved.

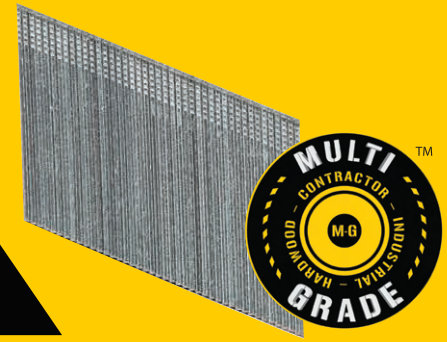

- DESCRIPTION:**
- Chisel Point - Smooth Shank.
  - Electro Galvanized Steel - Meets ASTM F1667.
  - Available in Stainless Steel.
  - Contractor Packed - 4,000 per Box.
  - Made with Premium Grade Steel to Provide Exceptional Performance.
  - Guaranteed to Deliver Worry-free Performance.
  - Excellent for Interior Finish, Trim Work, Hardwood Flooring, Baseboards, and More!

Verify Compatibility by Consulting Owner Manual

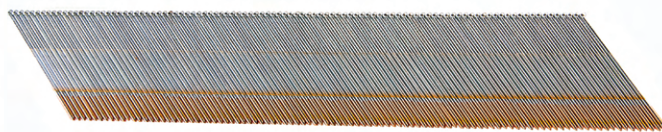

DA13-100	1" (25mm)	E-G Galvanized	Chisel Point	4,000 x 4 16,000	24.2 lbs
DA15-125	1 1/4" (32mm)	E-G Galvanized	Chisel Point	4,000 x 4 16,000	23.7 lbs
DA17-150	1 1/2" (38mm)	E-G Galvanized	Chisel Point	4,000 x 4 16,000	24.4 lbs
DA19-175	1 3/4" (45mm)	E-G Galvanized	Chisel Point	4,000 x 4 16,000	33.0 lbs
DA21-200	2" (50mm)	E-G Galvanized	Chisel Point	4,000 x 4 16,000	36.7 lbs
DA21-200SS	2" (50mm)	<b>Stainless Steel</b>	Chisel Point	4,000 x 4 16,000	36.7 lbs
DA25-250	2 1/2" (64mm)	E-G Galvanized	Chisel Point	4,000 x 4 16,000	45.8 lbs
DA25-250SS	2 1/2" (64mm)	<b>Stainless Steel</b>	Chisel Point	4,000 x 4 16,000	45.3 lbs



Learn more at  
[Pro-DriveFasteners.com](http://Pro-DriveFasteners.com)

Electro Galvanized steel provides a very thin layer of coating with a measure of protection against the elements. Over time these nails may corrode.

Not recommended for exterior application or ACO Treated Lumber.

**⚠️ WARNING:** This product can expose you to chemicals including Nickel and Lead which are known to the State of California to cause cancer.

For more information visit: [www.P65Warnings.ca.gov](http://www.P65Warnings.ca.gov)



# 16 GA FINISH NAILS

0° ANGLE "STRAIGHT" COLLATED STRIP  
20° ANGLE COLLATED STRIP

Fits most straight, no angle 16-gauge finish tools.



## DESCRIPTION:

- Blunt Chisel Point - Smooth Shank.
- Electro Galvanized Steel - Available in **Stainless Steel**
- Contractor Packed - 2,500 per box.
- Meets ASTM F1667
- Made with Premium Steel Guaranteed not to Jam Your Tool
- Excellent for Interior finish, Trim Work, Hardwood Flooring, Baseboards, and More!

Verify Compatibility by Consulting Owner Manual

## 16GA 0° ANGLE "STRAIGHT" COLLATED STRIP FINISH NAILS

C25-100	1" (25 mm)	E-G Galvanized	Chisel Point	2,500 x 10 25,000	21.8 lbs
C32-125	1 1/4" (32mm)	E-G Galvanized	Chisel Point	2,500 x 12 30,000	32.8 lbs
C38-150	1 1/2" (38mm)	E-G Galvanized	Chisel Point	2,500 x 12 30,000	38.4 lbs
C45-175	1 3/4" (44mm)	E-G Galvanized	Chisel Point	2,500 x 12 30,000	45.1 lbs
C50-200	2" (50mm)	E-G Galvanized	Chisel Point	2,500 x 12 30,000	49.8 lbs
C50-200SS	2" (50mm)	<b>Stainless Steel</b>	Chisel Point	2,500 x 12 30,000	49.8 lbs
C64-250	2 1/2" (64mm)	E-G Galvanized	Chisel Point	2,500 x 8 20,000	42.2 lbs
C64-250SS	2 1/2" (64mm)	<b>Stainless Steel</b>	Chisel Point	2,500 x 12 30,000	42.2 lbs

## 16GA 20° PASLODE® ANGLE COLLATED STRIP FINISH NAILS

AFN50-200	2" (50mm)	E-G Galvanized	Chisel Point	2,000 x 10 20,000	43 lbs
-----------	-----------	----------------	--------------	----------------------	--------

### Precision engineered to interchange:

Dewalt DCN660D1, Metabo HPT NT65M2SM, MAX NF565A/16, Omer 14.50, Paslode IM250S-Li, T250S-F16, Senco 16XP, Stanley Bostitch FN1664K. Designed to be Universal fit for most straight no angle 16 gauge finish nailers.



Learn more at  
[Pro-DriveFasteners.com](http://Pro-DriveFasteners.com)

Electro Galvanized steel provides a very thin layer of coating with a measure of protection against the elements. Over time these nails may corrode.

Not recommended for exterior application or ACO Treated Lumber.

To ensure maximum protection, use Stainless Steel type 316 staples.

**⚠️ WARNING:** This product can expose you to chemicals including Nickel and Lead which are known to the State of California to cause cancer.

For more information visit: [www.P65Warnings.ca.gov](http://www.P65Warnings.ca.gov)



# 18 GA FINISH NAILS

0° ANGLE "STRAIGHT" COLLATED STRIP

Our brad finish nails are professional grade quality, contractor-tested and approved.

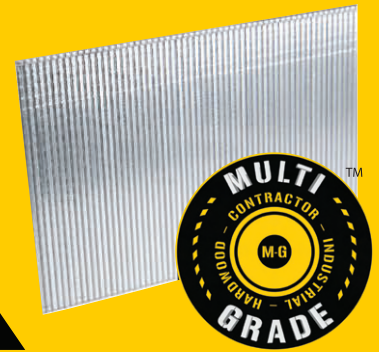

- DESCRIPTION:**
- Chisel Point - Smooth shank.
  - Electro Galvanized Steel - Meets ASTM F1667.
  - Contractor Packed - 5,000 per box.
  - Made with Premium Grade Steel to Provide Exceptional Performance.
  - Guaranteed to Deliver Worry-free Performance.
  - Excellent for Interior Finish, Trim Work, Hardwood Flooring, Baseboards, and More!

Verify Compatibility by Consulting Owner Manual

## 18GA 0° ANGLE "STRAIGHT" COLLATED STRIP BRAD NAILS "SLIGHT HEAD"



AXX08EAA-500	1/2"	E-G Galvanized	Chisel Point	5,000 x 12 60,000	10 lbs
AXX10EAA-625	5/8"	E-G Galvanized	Chisel Point	5,000 x 12 60,000	10 lbs
AXX11EAA-750	3/4"	E-G Galvanized	Chisel Point	5,000 x 12 60,000	10 lbs
AXX13EAA-100	1"	E-G Galvanized	Chisel Point	5,000 x 12 60,000	12 lbs
AXX15EAA-125	1-1/4"	E-G Galvanized	Chisel Point	5,000 x 12 60,000	12 lbs
AXX17EAA-150	1-1/2"	E-G Galvanized	Chisel Point	5,000 x 12 60,000	12 lbs
AXX21EAA-200	2"	E-G Galvanized	Chisel Point	5,000 x 12 60,000	12 lbs
AXX11EAA-750SS	3/4"	<b>Stainless Steel</b>	Chisel Point	1,000 x 8 8,000	8 lbs

### Precision engineered to interchange:

Duo-Fast 4450, 4450ST, Dewalt DC608K, DCN680D1, DCN680B, DWFP12233, Grip-Rite GRTBN200, Grex 1850GB, Paslode T200 F18, IM200-Li, Senco Finish-Pro FP25XP, FinishPro 18MG, SLP20XP, FinishPro 2N1, FP18MG, FN55AX, Metabo HPT NT50AE2M, Stanley Bostitch BT1855K, SB-2IN1, and designed to be Universal fit for most straight no angle 18ga "Medium HEAD" finish nailers.

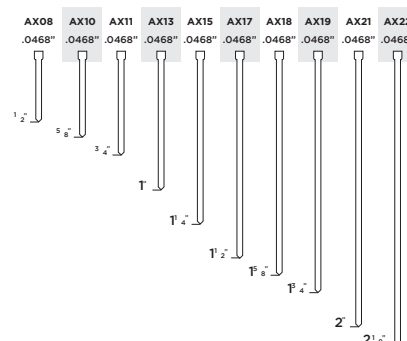

Learn more at  
[Pro-DriveFasteners.com](http://Pro-DriveFasteners.com)

Electro Galvanized steel provides a very thin layer of coating with a measure of protection against the elements. Over time these nails may corrode.

Not recommended for exterior application or ACO Treated Lumber.

**⚠ WARNING:** This product can expose you to chemicals including Nickel and Lead which are known to the State of California to cause cancer.

For more information visit: [www.P65Warnings.ca.gov](http://www.P65Warnings.ca.gov)





# 23 GA HEADLESS PIN NAILS

## MICRO PINS



Micro Pins fasten the smallest of trim securely, leaving a nearly invisible hole.

- DESCRIPTION:**
- Chisel point • Smooth shank - Electro Galvanized Steel
  - Convenient 4,500 ct Project Pack and 10,000 ct Job Pack
  - Directional Arrows are Painted on Strips to Eliminate Loading Error.
  - Micro Pins Fasten with a Nearly Invisible Hole
  - Our Brad Finish Nails are Contractor Tested and Proven
  - Meets ASTM F1667

Verify Compatibility by Consulting Owner Manual

### 23GA PINS NAILS

CZ10-58	5/8" (16mm)	E-G Galvanized	Chisel Point	4,500 x 24 108,000	10.1 lbs
CZ11-34	3/4" (19mm)	E-G Galvanized	Chisel Point	4,500 x 24 108,000	11.3 lbs
CZ13-100	1" (25mm)	E-G Galvanized	Chisel Point	4,500 x 24 108,000	16.0 lbs
CZ16-138	1 3/8" (35mm)	E-G Galvanized	Chisel Point	4,500 x 24 108,000	20.8 lbs

CZ08-500-10	1/2" (13mm)	E-G Galvanized	Chisel Point	10,000 x 48 480,000	35.0 lbs
CZ10-58-10	5/8" (16mm)	E-G Galvanized	Chisel Point	10,000 x 48 480,000	43.0 lbs
CZ-11-34-10	3/4" (19mm)	E-G Galvanized	Chisel Point	10,000 x 48 480,000	48.1 lbs
CZ13-100-10	1" (25mm)	E-G Galvanized	Chisel Point	10,000 x 48 480,000	69.0 lbs
CZ16-138-10	1 3/8" (35mm)	E-G Galvanized	Chisel Point	10,000 x 24 240,000	45.5 lbs



Eliminate loading errors with direction arrows

#### Precision engineered to interchange:

Cadex 23/15-10M, Duo-Fast 2320, Fasco ES2316P, Grex P6/15L, Grip-Rite GR58PIN, Grizzly H5044, Hitachi 23000, Interchange MP23-58-I (23225), Metabo HPT (23000), Porter-Cable PPN23063, Prebena AL16CRF, Senco A100629 (CZ10EAAN), Spotnails 23010, Unicatch CZ16 (87946) and many other 23ga Mirco Pin capable tools

#### Application Including and Not Limited To:

- Interior finish and trim
- Carving and ornamentals
- Rattan furniture production, picture and mirror frames, window beading
- Molding
- Decorative trim
- Cabinets
- Picture and mirror frames
- Ornamentals
- And many more applications requiring Headless pin nail

#### Compatible Tools:

Cadex 23/15-10M, Duo-Fast 2320, Fasco ES2316P, Grex P6/15L, Grip-Rite GR58PIN, Grizzly H5044, Hitachi 23000, Interchange MP23-58-I (23225), Metabo HPT (23000), Porter-Cable PPN23063, Prebena AL16CRF, Senco A100629 (CZ10EAAN), Spotnails 23010, Unicatch CZ16 (87946), and many other 23ga Mirco Pin capable tools

This product is made and sold by Pro-Drive Fasteners® and has no relationship with any of the other companies whose trademarks or item numbers are mentioned above.



Learn more at  
[Pro-DriveFasteners.com](http://Pro-DriveFasteners.com)

Electro Galvanized steel provides a very thin layer of coating with a measure of protection against the elements. Over time these nails may corrode.

Not recommended for exterior application or ACO Treated Lumber.

**⚠️ WARNING:** This product can expose you to chemicals including Nickel and Lead which are known to the State of California to cause cancer.

For more information visit: [www.P65Warnings.ca.gov](http://www.P65Warnings.ca.gov)





# 20 GA STAPLES

20GA "PAD" STAPLES

20GA "STAIR TREAD PAD" STAPLES TAN CROWN

Similar to Rapid 19 Arrow T-50



- DESCRIPTION:**
- Made from Extra Hard Wire
  - Resin Coated and Galvanized

Verify Compatibility by Consulting Owner Manual

## DIVERGENT STAPLES

**Applications:** Bedding Carpet Pad, Insulation, Roofing, House Wrap, light wood assembly, Poly Sheeting, roof paper, upholstery



### 20GA "PAD" STAPLES

<b>A11-10D</b>	3/8" Leg	13/32" Crown	20 GA	E-G Galvanized	Chisel Point	5,000 x 20 100,000
----------------	----------	--------------	-------	----------------	--------------	-----------------------

Arrow T50, Duo-Fast A-11, Arrow T-55, Senco H, Senco A-11, Rapid 11, JK671 staples, and other A11-10- series staplers

<b>5010-D</b>	3/8" Leg	1/2" Crown	20 GA	E-G Galvanized	Chisel Point	5,000 x 20 100,000
---------------	----------	------------	-------	----------------	--------------	-----------------------

Compatible Fasteners: BeA 95, Haubold 900, JK64, Prebena AD, Spotnails 35, Fasco ED-50. and other 5000 series staples

<b>7512D</b>	3/8" Leg	15/32" Crown	19 GA	E-G Galvanized	Chisel Point	5,000 x 20 100,000
--------------	----------	--------------	-------	----------------	--------------	-----------------------

Carpet pad staples for use in in hammer tackers using 7500 series staples (Duo-Fast HT-755, HT-755M & others).

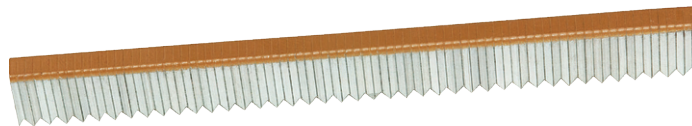

### 20GA "STAIR TREAD PAD" STAPLES TAN CROWN

<b>5418D</b>	9/16" Leg	3/16" Crown	19 GA	E-G Galvanized	Chisel Point	5,000 x 20 100,000
--------------	-----------	-------------	-------	----------------	--------------	-----------------------

**Applications:** For use with electric tacker staples are used to fasten carpet treads on stairs, upholstery, bedding.

**Compatible Tools:** For use in electric and pneumatic tools-Bostitch: CR1000E; , Cran 625 Pro Stapler , Duo-Fast DNS-5424, ENC-5418A, BN-5424, SShot 5424;Duo-Fast DNS-5424, ENC-5418A, BN-5424, SShot 5424; Fasco: F1A 54DF-18, F1B 54DF-18

This product is made and sold by Pro-Drive Fasteners® and has no relationship with any of the other companies whose trademarks or item numbers are mentioned above.



Learn more at  
[Pro-DriveFasteners.com](http://Pro-DriveFasteners.com)

Electro Galvanized steel provides a very thin layer of coating with a measure of protection against the elements. Over time these nails may corrode.

Not recommended for exterior application or ACO Treated Lumber.

⚠️ **WARNING:** This product can expose you to chemicals including Nickel and Lead which are known to the State of California to cause cancer.

For more information visit: [www.P65Warnings.ca.gov](http://www.P65Warnings.ca.gov)



# 20 & 22 GA STAPLES

1/2" CROWN X 20 GA STAPLES

3/16" CROWN X 20 GA STAPLES

Designed for high-speed Air Powered (Pneumatic) Staple Guns



- DESCRIPTION:**
- Made from Extra Hard Wire
  - Highest Quality for Industrial and Commercial use
  - Meets or Exceeds ASTM A641
  - Guarantee performance will no jamming
- Verify Compatibility by Consulting Owner Manual

## 1/2" CROWN X 20 GA STAPLES

<b>80/10 C</b>	3/8" Leg x 1/2" Crown	E-G Galvanized	Chisel Point	10,000 x 10 100,000	29.2 lbs
<b>80/12 C</b>	1/2" Leg x 1/2" Crown	E-G Galvanized	Chisel Point	10,000 x 10 100,000	42.6 lbs

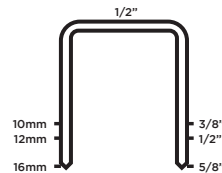

### Applications:

Upholstery staple, bedding, dust covers, arts and crafts, picture framing, corner blocks, packaging, carpeting and many more light assembly applications.

### Precision engineered to interchange:

BEA 80/380, Bostitch AZ33, Atro 8, JK680, Spotnails 80, Haubold 800, Empire 8, Rainco 8, Fasco EB80XX.

### Guaranteed to work with:

BeA: 80, 380/16; ,Fasco F1B 80-16, S80-16, F1A 80-16, F1B 80-16 LN 50MM, F1A 80-16 LN50MM, F1A 80-16 AUTO LM, F1B 80-16 AUTO LM; Bostitch: 21680B, 21680BLN, 21680B-ALM, BA-T400; Josef Kihlberg JK20-680, JK20A-680 Auto, JK20A-680L Auto Long magazine , Haubold: N814; Spotnails BS8016AF, JS8016(LN), PS8016, BS8016AF, DS8016, TES8118;

## 3/16" CROWN X 20 GA STAPLES

<b>BEA-97/12</b>	1/2" Leg x 3/16" Crown	E-G Galvanized	Chisel Point	20,800 x 6 124,800	31.6 lbs
<b>BEA-97/16</b>	5/8" Leg x 3/16" Crown	E-G Galvanized	Chisel Point	10,000 x 10 100,000	30.2 lbs

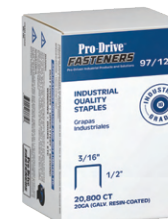
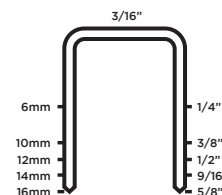

### Applications:

Auto Industry, Case Backs, Cabinetry, Chairs, Drawer Runners, Picture Framing, Lattice Panels, TV and Stereo Cabinets, Upholstered Furniture , Wicker and Rattan Furniture

### Precision engineered to interchange:

Spotnails 97, BeA 97, Atro 97, Prebena O, JK 690 staples.

### Guaranteed to work with:

S3297-LHF-2, LHF97125, Duo-Fast ENC-5418A, Fasco F1A 97B-25, F1B 97B-25, F21P 97B-25, F21P 97B-25A staplers.

This product is made and sold by Pro-Drive Fasteners® and has no relationship with any of the other companies whose trademarks or item numbers are mentioned above.



Learn more at  
[Pro-DriveFasteners.com](http://Pro-DriveFasteners.com)

Electro Galvanized steel provides a very thin layer of coating with a measure of protection against the elements. Over time these nails may corrode. Not recommended for exterior application or ACO Treated Lumber. To ensure maximum protection, use Stainless Steel type 316 staples.

**⚠ WARNING:** This product can expose you to chemicals including Nickel and Lead which are known to the State of California to cause cancer.

For more information visit: [www.P65Warnings.ca.gov](http://www.P65Warnings.ca.gov)



# 22 GA STAPLES

## 3/8" CROWN X 22GA STAPLES (BEA 71 SERIES & SENCO C SERIES)



Designed for high-speed Air Powered (Pneumatic) Staple Guns

- DESCRIPTION:**
- Made from Extra Hard Wire
  - Highest Quality for Industrial and Commercial use
  - Meets or Exceeds ASTM A641
  - Guaranteed performance– will not jam

Verify Compatibility by Consulting Owner Manual

### 3/8" CROWN X 22GA STAPLES (BEA 71 SERIES & SENCO C SERIES)

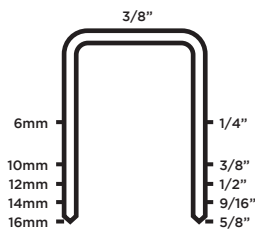

BA7106	1/4" Leg x 3/8" Crown	E-G Galvanized	Chisel Point	20,000 x 10 200,000	26.1 lbs
BA7110	3/8" Leg x 3/8" Crown	E-G Galvanized	Chisel Point	20,000 x 10 200,000	34.53 lbs
BA71-12	1/2" Leg x 3/8" Crown	E-G Galvanized	Chisel Point	20,000 x 10 200,000	???
BA71-14	9/16" Leg x 3/8" Crown	E-G Galvanized	Chisel Point	20,000 x 10 200,000	???
BA7106SS	1/4" Leg x 3/8" Crown	<b>Stainless Steel</b>	Chisel Point	20,000 x 10 200,000	24.2 lbs
BA7110SS	3/8" Leg x 3/8" Crown	<b>Stainless Steel</b>	Chisel Point	20,000 x 10 200,000	28.3 lbs
BA7112SS	1/2" Leg x 3/8" Crown	<b>Stainless Steel</b>	Chisel Point	20,000 x 10 200,000	???



#### Applications:

Upholstery staple, bedding, dust covers, arts and crafts, picture framing, corner blocks, packaging, carpeting, molding and many more light assembly applications.

#### Precision engineered to interchange:

ATRO 90, BEA 90, DUO FAST 1800, PREBENA EB, HAUBOLD KL 6000, HITACHI N3804, PORTER CABLE NS 100 & NS150A, SENCO L, SPOTNAILS 4800, JK 781

#### Guaranteed to work with:

BeA:71/15-421, FASCO: F1A 7C-16, FIA S3G-16, FIB 7C-16, F1B S3G-16, F1B SR3-16, Porter Cable US58; Spotnails JS7116, JS7116LN, IS7116, BS7116AF, PS7116, Senco STF10-C, SFW09-C, SFW10XP-C, SFW08C, SFT10-C, SJ10-C, Fasco F1A 7C-16, F1B 7C-16, F1B 7C-16 AUTO, F1B 7C-16 LN50, F1B 7C-16 ALM air staple guns; Fasco Maestri ME-3G electric staple guns

This product is made and sold by Pro-Drive Fasteners® and has no relationship with any of the other companies whose trademarks or item numbers are mentioned above.



Learn more at  
[Pro-DriveFasteners.com](http://Pro-DriveFasteners.com)

Electro Galvanized steel provides a very thin layer of coating with a measure of protection against the elements. Over time these nails may corrode. Not recommended for exterior application or ACO Treated Lumber. To ensure maximum protection, use Stainless Steel type 316 staples.

**⚠ WARNING:** This product can expose you to chemicals including Nickel and Lead which are known to the State of California to cause cancer.

For more information visit: [www.P65Warnings.ca.gov](http://www.P65Warnings.ca.gov)



# AIR TOOLS

18GA BRAD NAILER  
16GA BRAD NAILER  
23 GA MICRO PINNER



## AIR TOOLS

<b>BRAD18</b>	18 GA Brad Nailer
<b>BRAD16</b>	16 GA Brad Nailer
<b>MICRO-23</b>	23 GA Micro Pin Nailer

### BRAD18



360° exhaust deflector  
E-Z tool-free depth-adjustment device  
EZ front access for removing jam  
Easy open magazine latch No-mar pad

Weight	Dimensions (L*W*H)	Operated Pressure	Load Capacity	Range
3.06 lbs	9.7"x2.4"x9.9"	70 - 110 psi	110 Brads	5/8" - 2"

Precision engineered to work with most straight (no angle) 18-gauge finish nails

### BRAD16



Accept 15 / 16GA Finish Nails  
360° Adjustable Air Deflector  
Quick Release Nose Cover  
Well Balanced

Weight	Dimensions (L*W*H)	Operated Pressure	Load Capacity	Range
4.19 lbs	10.7" x 2.8" x 11.1"	70 - 110 psi	100 Nails	5/8" - 2 1/2"

Precision engineered to work with most straight no angle 16-gauge finish nails  
No-Mar Rubber Pad Available (#21903602)

### MICRO23



Can be used with Both Headless and Mini Head Pins  
Belt hook  
Rear Exhaust to Avoid Oil Stains on working surface  
One hand Side Loading Magazine  
Removable No-Mar Rubber Pad  
Nail Lockout to Avoid Empty Shots  
User friendly full Wrap-Around Rubber Grip  
Slim Tapered Nose for Precise Nail Placement

Weight	Dimensions (L*W*H)	Operated Pressure	Load Capacity	Range
2.01 lbs	8.07 x 1.69" x 6.85"	70 - 100 psi	120 Pins	1/2" - 1 3/8"

**Precision engineered to work with:** Cadex 23/15-10M, Duo-Fast 2320, Fasco ES2316P, Grex P6/15L, Grip-Rite GR58PIN, Grizzly H5044, Hitachi 23000, Interchange MP23-58-I (23225), Metabo HPT (23000), Porter-Cable PPN23063, Prebena AL16CRF, Senco A100629 (CZ10EAAAN), Spotnails 23010, Unicatch CZ16 (87946), and many other 23ga Mirco Pin capable tools

This product is made and sold by Pro-Drive Fasteners® and has no relationship with any of the other companies whose trademarks or item numbers are mentioned above.



Learn more at  
[Pro-DriveFasteners.com](http://Pro-DriveFasteners.com)

Electro Galvanized steel provides a very thin layer of coating with a measure of protection against the elements. Over time these nails may corrode. Not recommended for exterior application or ACO Treated Lumber. **To ensure maximum protection, use Stainless Steel type 316 staples.**

**⚠ WARNING:** This product can expose you to chemicals including Nickel and Lead which are known to the State of California to cause cancer.

For more information visit: [www.P65Warnings.ca.gov](http://www.P65Warnings.ca.gov)



# AIR TOOLS

16 GA WIDE CROWN STAPLER  
16 GA MEDIUM CROWN STAPLER  
97 SERIES FINE WIRE STAPLER



## L WIRE STAPLER #L18-NC



18 Ga. 1/4" Narrow Staples

360° exhaust deflector  
Switchable trigger  
E-Z tool free depth-adjustment  
EZ front de-jamming

Narrow nose piece  
No-mar pad  
Capacity: 110pcs  
TOP LOADING

Weight	Dimensions (L*W*H)	Operated Pressure	Load Capacity	Range
2.97 lbs	10.9"x2.4"x10"	70 - 110 psi	110 Staples	3/4" - 1 5/8"

Precision engineered to work with most 1/4" narrow crown 18-gauge staples

## N WIRE STAPLER #M18-38



Quick-Release Nose Jam Clearance feature no tool required  
High-speed firing up to 13 staples second  
Dedicated Bump Fire (Orange) or Full Sequential Trigger (Black) Available  
Quick Loading Open Magazine  
Magazine has E-Z viewing fastener capacity

Weight	Dimensions (L*W*H)	Operated Pressure	Load Capacity	Range
4.8 lbs	14 7/8" x 2 7/8" x 10 7/8"	70 - 110 psi	140 staples	1" - 2"

**Precision engineered to work with:** BeA16® (155 ), Duo-Fast® 7600 ,  
Haubold ®KG 700, Senco® N, and many more standard 7/16" crown staples  
17 GA-Compatible with Senco® O Series

## M WIRE STAPLER #9716-22



360° exhaust deflector  
Switchable trigger  
E-Z tool free depth-adjustment  
EZ front de-jamming

Narrow nose piece  
No-mar pad  
Capacity: 110pcs  
TOP LOADING

Weight	Dimensions (L*W*H)	Operated Pressure	Load Capacity	Range
4.6 lbs	11.9"x3.2"x10.4"	70 - 110 psi	130 Staples	3/4" - 1 5/8"

Precision engineered to work with most 3/8" crown 18-gauge staples

## L WIRE STAPLER #78150L



8GA Underlayment Stapler  
Extra Long Magazine  
Crown: 1/4" L WIRE  
Designed for 3/8" to 5/8" (10 mm to 16 mm) engineered flooring

Weight	Dimensions (L*W*H)	Operated Pressure	Load Capacity	Range
???????	14" x 2.5" x 9.5"	75 - 100 psi	???????	7/8" - 1-9/16"

Precision engineered to work with most 3/8" crown 18-gauge staples

This product is made and sold by Pro-Drive Fasteners® and has no relationship with any of the other companies whose trademarks or item numbers are mentioned above.



Learn more at  
[Pro-DriveFasteners.com](http://Pro-DriveFasteners.com)

Electro Galvanized steel provides a very thin layer of coating with a measure of protection against the elements. Over time these nails may corrode. Not recommended for exterior application or ACO Treated Lumber. To ensure maximum protection, use Stainless Steel type 316 staples.

⚠️ WARNING: This product can expose you to chemicals including Nickel and Lead which are known to the State of California to cause cancer.

For more information visit: [www.P65Warnings.ca.gov](http://www.P65Warnings.ca.gov)





# AIR TOOLS

P WIRE STAPLER  
M WIRE STAPLER



## W AND 97 SERIES STAPLER 22 GA #N16-MC



Standard Double trigger for increased safety  
Bottom Load, Jam Free Magazine  
Rear Exhaust to Avoid Oil Stains on working surface  
Slim Long Nose for Easy, Precise Staple Placement  
Extended Trigger design for Rapid Stapling  
User friendly full Wrap-Around Rubber Grip

Weight	Dimensions (L*W*H)	Operated Pressure	Load Capacity	Range
1.95 lbs	8.6" x 1.7" x 5.7"	60 - 100 psi	125 Staples	1/4" - 5/8"

**Precision engineered to work with:** BeA®97, Haubold® 4000 Omer® 4097, Senco® W Series and many more standard 97 (3/16" Crown) series staples

## P WIRE STAPLER #P16-WC



E-Z Quick Release Nose Cover  
360° Adjustable Air Deflector  
Heavy Duty, Well Balanced  
Sequential Fire Trigger Available

Weight	Dimensions (L*W*H)	Operated Pressure	Load Capacity	Range
5.6lbs	14.7" x 2.75" x 10.23"	85 - 110 psi	160 Staples	3/4 - 1 1/2"

**Precision engineered to work with:** BeA® 145 ,Duo-Fast ®1700, Fasco® ES6 ,Hitachi® N3824A, Senco® P, , Spotnails® 3600, Prebena® WS & W, series staples.and many more standard 1" crown staples

This product is made and sold by Pro-Drive Fasteners® and has no relationship with any of the other companies whose trademarks or item numbers are mentioned above.



Learn more at  
[Pro-DriveFasteners.com](http://Pro-DriveFasteners.com)

Electro Galvanized steel provides a very thin layer of coating with a measure of protection against the elements. Over time these nails may corrode. Not recommended for exterior application or ACO Treated Lumber. **To ensure maximum protection, use Stainless Steel type 316 staples.**

**⚠ WARNING:** This product can expose you to chemicals including Nickel and Lead which are known to the State of California to cause cancer.

For more information visit: [www.P65Warnings.ca.gov](http://www.P65Warnings.ca.gov)



# AIR SANDERS

JB-3-4



## 3" X 4" Jitterbug Air Sander with Square pad

### JB-3-4

PAD SIZE:	3" x 4"
ORBIT DIAMETER OFFERED:	1/8"
FREE SPEED:	12,000 RPM
AVG. AIR CONS:	10.5 CFM
AIR PRESSURE:	90 PSI (6.2 bar)
NET WEIGHT:	1.63 Lbs/0.74 kgs
AIR INLET:	1/4"
AIR HOSE I.D. :	2.5 m/52
SOUND PRESSURE:	79 dB/AJ
PACKING:	10pvs/ctn GW" 16.30Lbs/7.4kgs



### PADS

AS-3-4 PAD-HL <> 3" X 4" SANDING PAD (HOOK & LOOP)



### AAS-JB 3-4 REPAIR KIT

#### MAINTANCE REPAIR KIT INCLUDES ALL OF THE BELOW ITEMS

Ball Bearing # 2 (2314) • Rotor #6 (309N-14F) • Rotor Blade #7 (305N-13) has 5 rotors • Ball Bearing #10 (00-2314) • Rotor Key #8 (3701A) Silencer • Assembly #48 (A3090N-37) • Valve Washer #49 2080N-49 • Valve #50 (2080N-50) • Valve Spring #51 92080N-51

This product is made and sold by Pro-Drive Fasteners® and has no relationship with any of the other companies whose trademarks or item numbers are mentioned above.



Learn more at  
[Pro-DriveFasteners.com](http://Pro-DriveFasteners.com)

Electro Galvanized steel provides a very thin layer of coating with a measure of protection against the elements. Over time these nails may corrode. Not recommended for exterior application or ACO Treated Lumber. To ensure maximum protection, use Stainless Steel type 316 staples.

⚠ WARNING: This product can expose you to chemicals including Nickel and Lead which are known to the State of California to cause cancer.

For more information visit: [www.P65Warnings.ca.gov](http://www.P65Warnings.ca.gov)



# AIR SANDERS

AS-500

5" Orbital Industrial Level Dual Action Sander with Hook & Loop pad



## AS-500

PAD SIZE:	5"
ORBIT DIAMETER OFFERED:	3/16" or 3/32"
FREE SPEED:	12,000 RPM
AVG. AIR CONS:	1.6 CFM
AIR PRESSURE:	90 PSI (6.2 bar)
NET WEIGHT:	1.98 Lbs/0.9 kgs
AIR INLET:	1/4"
AIR HOSE I.D. :	3/8' (10mm)
SOUND PRESSURE:	80 dB(A)
PACKING:	10pvs/ctn GW" 26.5Lbs/12kgs



## PADS

AS-500V <> 5" PAD (VINYL, 5/16"

AS-500HL <> 5" PAD (HOOK & LOOP, 5/16")



## AS-500 REPAIR KIT

MAINTANCE REPAIR KIT INCLUDES ALL OF THE BELOW ITEMS

Sleeve Set #7 A11XAS • Valve set #5 OBS08AS • Bearing #12 70048A • Rotor #15 ST0B-21 • Rotor Blade #14 OB-20-3 (has 5 STEEL rotors)  
Ball Bearing #19 OB-26A • Rotor Key #22 ST70407

This product is made and sold by Pro-Drive Fasteners® and has no relationship with any of the other companies whose trademarks or item numbers are mentioned above.



Learn more at  
[Pro-DriveFasteners.com](http://Pro-DriveFasteners.com)

Electro Galvanized steel provides a very thin layer of coating with a measure of protection against the elements. Over time these nails may corrode. Not recommended for exterior application or ACO Treated Lumber. To ensure maximum protection, use Stainless Steel type 316 staples.

⚠ WARNING: This product can expose you to chemicals including Nickel and Lead which are known to the State of California to cause cancer.

For more information visit: [www.P65Warnings.ca.gov](http://www.P65Warnings.ca.gov)



# E-Z CONNECT™ BRAIDED AIR HOSE

E-Z CONNECT air hoses eliminate the need for whip hoses with straight sections.



- DESCRIPTION:**
- Maximum Working Pressure: 200psi.
  - Wall Thickness: .075 +/- .005.
  - Hose Inner Diameter: 1/4" Hose Outer Diameter: 3/8".
  - Field Repairable - All Units have Reusable Fittings that Allow In-field Repairs if Necessary.
  - Industrial Grade 6 Ball Couplers - Reusable Fitting.
  - Excellent Cold Weather Flexibility, Temp 40°f to 140°f (-40°c to 60°c).
  - High Abrasion-resistance - Smooth Finish will not Mar Surfaces .
  - Extremely Kink-resistant - Oil Resistant.
  - 40% To 50% Lighter than Traditional Air Hoses.



BLUE-AIR250-100	PU BRAID TU 1/4"0.375*100FT	12 per ctn	42.3 lbs
BLUE-AIR250-50	PU BRAID TU 1/4"0.375*50FT	20 per ctn	???
RED-AIR250-50R	PU BRAID TU 1/4"0.375*50FT	20 per ctn	3.7 lbs?



## E-Z CONNECT™ FITTINGS, COUPLERS & SPLICERS

AIR-MP20M	INDUSTRIAL SIX BALL 1/4"NPT MALE	10 per bag	0.43 lbs
AIR-MIC20F	MIC series Quick Coupler INDUSTRIAL NIPPLE,BRASS,1/4" NPT FEMALE	10 per bag	2.36 lbs
AIR-UCB1414	BRASS FITTING, REUSABLE SPLICER FOR 3/8"1/4 HOSE	10 per bag	1.6 lbs
AIR-SW-MP20M	360 degree MP Swivel nipple x 1/4" NPT male	10 per bag	1.9 lbs



AIR-SW-MP20M

- 360° swivel connector
- Eliminates air hose tangles
- Improves workflow with more effective tool placement



AIR-MP20F

- Male connector
- Professional grade nipple
- Brass plated steel



AIR-UCB1414

- Splicer for 3/8" Hose
- Requires minimal tools
- Reuseable and durable
- Quick & easy field repair
- Quality brass hex stock



AIR-MIC20F

- Quick coupler
- Knurled Body enhances grip
- Industrial 6 ball design



Learn more at  
[Pro-DriveFasteners.com](http://Pro-DriveFasteners.com)

Electro Galvanized steel provides a very thin layer of coating with a measure of protection against the elements. Over time these nails may corrode. Not recommended for exterior application or ACO Treated Lumber.

⚠ WARNING: This product can expose you to chemicals including Nickel and Lead which are known to the State of California to cause cancer.

For more information visit: [www.P65Warnings.ca.gov](http://www.P65Warnings.ca.gov)



# SUPERFLEX HYBRID REINFORCED PVC HOSE

Premium version of our EASY-CONNECT™ air hoses



- DESCRIPTION:**
- 1/4" x 0.375" X 50' NPT Male Brass Fitting, and Quick Coupler
  - Includes Plastic Guard



AIR PVC-YELLOW-50	FLEXIBLE PVC BRAID HOSE	12	39.1 lbs
YELLOW-CH1414	1/4" NPT HOSE BARB FITTING	10 per bag	12.4 lbs
YELLOW-FE14	1/4" FERRULE	10 per bag	7.2 lbs

Maximum Working Pressure 300 psi • Industrial Grade 6 Ball Couplers  
 High Abrasion-resistance - Smooth Finish will not Mar Surfaces  
 Extremely Kink-resistant • Oil Resistant • UV Resistant  
 35% Lighter than Traditional Rubber Hose • Temp -25°C +60°C  
 ROHS Compliant

All our fittings and couplers are industrial grade for heavy duty use.

Designed for use in the DIY market as well meeting the demands of the professional tradesman.

You can count on our E-Z Connect line to provide reliable performance for many tool applications and uses.



Learn more at  
[Pro-DriveFasteners.com](http://Pro-DriveFasteners.com)

Electro Galvanized steel provides a very thin layer of coating with a measure of protection against the elements. Over time these nails may corrode. Not recommended for exterior application or ACO Treated Lumber. To ensure maximum protection, use Stainless Steel type 316 staples. WARNING: This product can expose you to chemicals including Nickel and Lead which are known to the State of California to cause cancer. For more information visit: [www.P65Warnings.ca.gov](http://www.P65Warnings.ca.gov)





# URETHANE STRIKING FACES

Guaranteed to fit leading brands of flooring urethane cap mallets or your money back.



- DESCRIPTION:**
- Guaranteed to all fit the major brands with 3/8" x 16 standard thread.
  - Ideal replacement for 2" Poly Faces.
  - Five different colors denoting hardness and densities.
  - Unaffected by liquids, solvents and lubricants.
  - Will not damage, mar, dent, or deface, while providing a solid, high-impact and resilient striking face.
  - Free counter display with purchase of 16 Poly Striking Faces.



2" Poly Cap - SOFT ITEM# POLY01-ORG	16 per case
2" Poly Cap - SOFT/Med ITEM# POLY01-BRO	16 per case
2" Poly Cap - MEDIUM ITEM# POLY01-GRE	16 per case
2" Poly Cap - TOUGH ITEM# POLY01-RED	16 per case
2" Poly Cap - HARD ITEM# POLY01-BLK	16 per case



Learn more at  
[Pro-DriveFasteners.com](http://Pro-DriveFasteners.com)

Electro Galvanized steel provides a very thin layer of coating with a measure of protection against the elements. Over time these nails may corrode. Not recommended for exterior application or ACO Treated Lumber. To ensure maximum protection, use Stainless Steel type 316 staples. WARNING: This product can expose you to chemicals including Nickel and Lead which are known to the State of California to cause cancer. For more information visit: [www.P65Warnings.ca.gov](http://www.P65Warnings.ca.gov)



# POLY DEAD BLOW HAMMER



Head Design Provides Greater Service Life (Patent Pending)

100% Premium Hickory Handle

## ITEM #'S:

**200L-OB**

with Orange & Brown Poly caps

**200L-OG**

with Orange & Green Poly caps

**200L-POLY-O-BL**

with Orange & Black Poly caps

**200L-POLY-BR-BR**

with Brown & Brown Poly caps

## KEY FEATURES:

- Head cavity partially filled with iron shot, to provide greater striking force
- Face absorbs portion of blow's energy.
- Force of blow transmitted solidly to strike surface.

POLY Dead Blow Hammer - 2" Poly Face*	ITEM# 200L-POLY	2.4 lbs
---------------------------------------	-----------------	---------



**200L-2000** -  
Replace Inserts



**200L-1000** - Steel  
Replacement Shot



# MALLET CAPS (Rubber)

Guaranteed to fit leading brands of flooring rubber cap mallets or your money back



- DESCRIPTION:**
- Easy to Install.
  - Heavy-duty chrome-plated retention ring.



Ideal Replacement for Black Caps

**GREY MALLET CAP ITEM# CAP602G** 24 Per Case

- Great for Pre-Finished and Unfinished wood!



**WHITE MALLET CAP ITEM# CAP600W** 24 Per Case

- Great for Pre-Finished and Unfinished wood!



NEW!

**NEW! PRO-ANGLE<sup>®</sup> MALLET CAP ITEM# CAP600PA** 24 Per Case

- This Cap offers an improved edge clearance for racking flooring strips.
- Great for Pre-Finished and Unfinished wood!



**BLACK MALLET CAP ITEM# CAP600B** 24 Per Case

- Great for Unfinished wood!



**VCAP RUBBER MALLET CAP ITEM# 23004-200** 24 Per Case

- 2" Diameter Soft White
- Compatible with Grainger Part Number 1TMB9
- Compatible with MSC Part Number 01893767

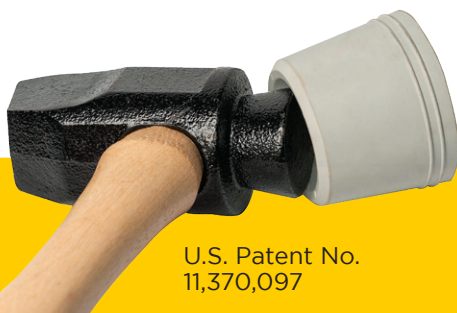

U.S. Patent No. 11,370,097

- Patented E-Z 2CAP™ design allows for easier and faster cap installation.
- Pro-Drive Fasteners™ caps will fit all major brands, *guaranteed*.

## E-Z 2CAP™



Learn more at [Pro-DriveFasteners.com](http://Pro-DriveFasteners.com)

Electro Galvanized steel provides a very thin layer of coating with a measure of protection against the elements. Over time these nails may corrode. Not recommended for exterior application or ACO Treated Lumber. To ensure maximum protection, use Stainless Steel type 316 staples. WARNING: This product can expose you to chemicals including Nickel and Lead which are known to the State of California to cause cancer. For more information visit: [www.P65Warnings.ca.gov](http://www.P65Warnings.ca.gov)



# MALLETS

Six-ring, easy-grip pattern along with flared handle provides slip resistance and ensures firm grip.



## DESCRIPTION:

- Available with white or black mallet caps
- Made in the USA and crafted from 100% premium hickory
- Comfortable, easy-to-grip 6-ring wood handle
- Made for use on use with pneumatic staplers or nailers
- Contractor proven and tested
- Epoxy-filled handle, attached with steel safety wedge
- PATENT PENDING SURE 2 LOCK™ head design will virtually eliminate loosening of handle - even after years of use

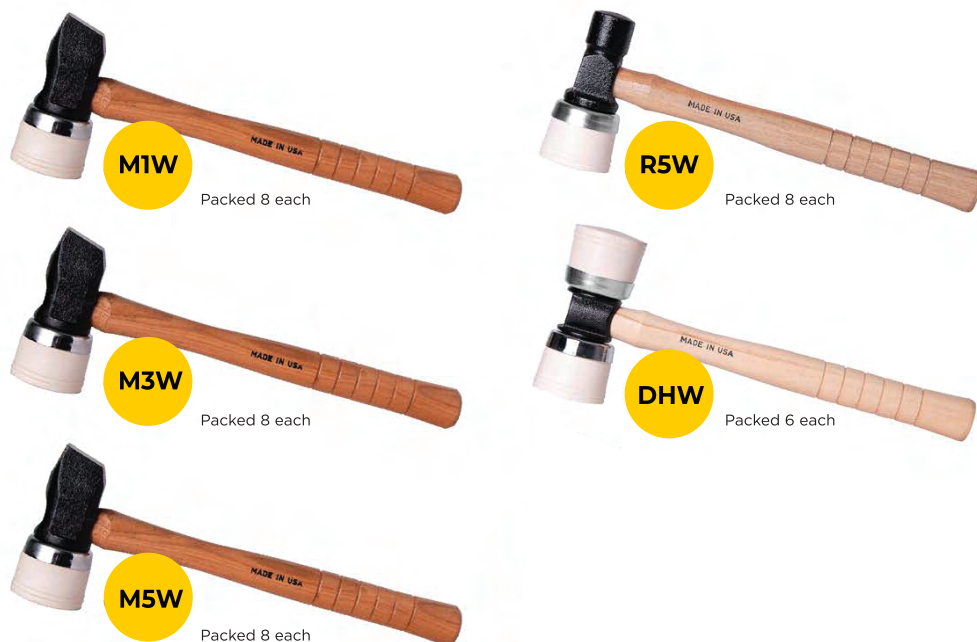

Steel Head/White Cap ITEM# M1W	15"	3.2 LBS.
Steel Head/White Cap ITEM# M3W	15"	3.6 LBS.
Steel Head/White Cap ITEM# M5W	15"	3.7 LBS.
Round Head/White Cap ITEM# R5W	15"	2.2 LBS.
Double Headed/White Cap ITEM# DHW	15"	3.4 LBS.



Learn more at  
[Pro-DriveFasteners.com](http://Pro-DriveFasteners.com)

WARNING: This product can expose you to chemicals including Nickel and Lead which are known to the State of California to cause cancer. For more information visit: [www.P65Warnings.ca.gov](http://www.P65Warnings.ca.gov)



# SPLIT HEAD HAMMER FACES (Rubber)

Our split-head, rubber, hammer faces are designed for the professional flooring installer.



- DESCRIPTION:**
- Easy to install.
  - Durable for pre-finished and unfinished wood.
  - Packed 12 to a case.
  - **NON-MARRING.**



Premium Mallet caps fit Garland® split head mallets



1 1/2"



2"

1 1/2" White Hammer Face ITEM# 23002-150	12 per case
2" White Hammer Face ITEM# 23004-200	12 per case



Learn more at  
[Pro-DriveFasteners.com](http://Pro-DriveFasteners.com)

Electro Galvanized steel provides a very thin layer of coating with a measure of protection against the elements. Over time these nails may corrode. Not recommended for exterior application or ACO Treated Lumber. To ensure maximum protection, use Stainless Steel type 316 staples. WARNING: This product can expose you to chemicals including Nickel and Lead which are known to the State of California to cause cancer. For more information visit: [www.P65Warnings.ca.gov](http://www.P65Warnings.ca.gov)





**VCAP™ RUBBER MALLET TIP 2" DIAMETER WHITE**  
**NON MARRING VCAP™ 2" HAMMER FACES (Rubber)**  
 Designed for the professional flooring installer.



- DESCRIPTION:**
- Easy to install.
  - Durable for engineering flooring and vinyl installation.
  - Packed 120 to a case.
  - **NON-MARRING.**

US PATENT # 11-759-941

**VCAP™ RUBBER MALLET TIP 2" DIAMETER WHITE**

ITEM # 100-V-CAP  
 NON-MARRING  
 Shipping Weight: 0.27 lbs  
 Compatible with Grainger Part Number 1TMB9  
 Compatible with MSC Part Number 01893767



1 1/2"



2"

Premium Mallet caps fit  
 Garland® split head mallets

Split-head mallets are NOT available  
 from Pro-Drive Fasteners

1 1/2" White Hammer Face ITEM# 23002-150	12 per case
2" White Hammer Face ITEM# 23004-200	12 per case



Learn more at  
[Pro-DriveFasteners.com](http://Pro-DriveFasteners.com)

WARNING: This product can expose you to chemicals including Nickel and Lead which are known to the State of California to cause cancer.  
 For more information visit: [www.P65Warnings.ca.gov](http://www.P65Warnings.ca.gov)



# E-Z CONNECT™

## XTRA LARGE PRO-TAPPING BLOCK

Durable, plastic tapping block - made from 1" solid, high-quality material.



- DESCRIPTION:**
- Ideal tapping block for Vinyl Plank, Engineered or Solid Hardwood Flooring.
  - Designed to eliminate use of a mallet. Use only one hand along with the E-Z CONNECT™ Pro-Tapping Block to set your flooring.
  - Makes for faster board placements - Ideal for longer planks.
  - Extra-long wooden D-Grip will virtually eliminate crushed fingers.
  - Balanced 46oz weight will provide enough heft to set planks with one or two strikes.
  - Both faces are smooth, providing excellent wear capability.
  - Measures 15 1/2" x 3 1/8".



E-Z CONNECT™ Extra Large Pro-Tapping Block 6 CT

ITEM# TB-PRO-312



Learn more at  
[Pro-DriveFasteners.com](http://Pro-DriveFasteners.com)

Electro Galvanized steel provides a very thin layer of coating with a measure of protection against the elements. Over time these nails may corrode. Not recommended for exterior application or ACO Treated Lumber. To ensure maximum protection, use Stainless Steel type 316 staples. WARNING: This product can expose you to chemicals including Nickel and Lead which are known to the State of California to cause cancer. For more information visit: [www.P65Warnings.ca.gov](http://www.P65Warnings.ca.gov)



# HAMMER TACKERS



<p><b>Hammer Tacker for A-11 or T-50</b></p>	<p>Staples 1/4" - 3/8" (6-10mm) Capacity 168 pcs, (2 STRIPS)</p>	<p><b>ITEM# HT A-11-10</b> Blue handle</p>
<p><b>Hammer Tacker for DUO-FAST 5000 series</b></p>	<p>Staples 1/4" - 3/8" (6-10mm) Capacity 168 pcs, (2 STRIPS)</p>	<p><b>ITEM# HT-5010</b> Blue handle</p>



Learn more at  
[Pro-DriveFasteners.com](http://Pro-DriveFasteners.com)

Electro Galvanized steel provides a very thin layer of coating with a measure of protection against the elements. Over time these nails may corrode. Not recommended for exterior application or ACO Treated Lumber. To ensure maximum protection, use Stainless Steel type 316 staples. WARNING: This product can expose you to chemicals including Nickel and Lead which are known to the State of California to cause cancer. For more information visit: [www.P65Warnings.ca.gov](http://www.P65Warnings.ca.gov)



# TIPPER-DE-TIPPER™

NEW DEVICE - Patent pending

The safest & fastest method to replace mallet caps!



- DESCRIPTION:**
- ELIMINATES RISK OF INJURY.
  - Replaces mallet caps in 30 seconds.
  - Robust construction - virtually no maintenance.
  - 5 STATION DESIGN fits all major brands of Round or Angle rubber caps.

PATENT # xxxxxxxxxxxxxx

Scan the QR code to see how easy this works



## TIPPING



## DE-TIPPING



Learn more at [Pro-DriveFasteners.com](http://Pro-DriveFasteners.com)

Electro Galvanized steel provides a very thin layer of coating with a measure of protection against the elements. Over time these nails may corrode. Not recommended for exterior application or ACO Treated Lumber. To ensure maximum protection, use Stainless Steel type 316 staples.

WARNING: This product can expose you to chemicals including Nickel and Lead which are known to the State of California to cause cancer.

For more information visit: [www.P65Warnings.ca.gov](http://www.P65Warnings.ca.gov)



# Pro-Drive<sup>®</sup> **FASTENERS**

Pro-Driven Industrial Products and Solutions™

Pro-Drive Fasteners is your one stop source of top-quality products for your fastening requirements.

With our extensive knowledge and experience, you can count on Pro-Drive Fasteners to be your one stop source for top-quality products. We don't follow trends or settle for second best. We strive to be innovative, industry leaders constantly looking to set the bar higher than ever before!

We have the products to meet all types of applications.



Pro-Driven  
Industrial Products  
and Solutions

**Pro-DriveFasteners.com**