

INAPOD

Office Pod Series

ASSEMBLY DIAGRAM



M-POD

MEETING POD
1-8 PEOPLE

INSTALLATION MANUAL

PHONE BOOTH SERIES
M POD

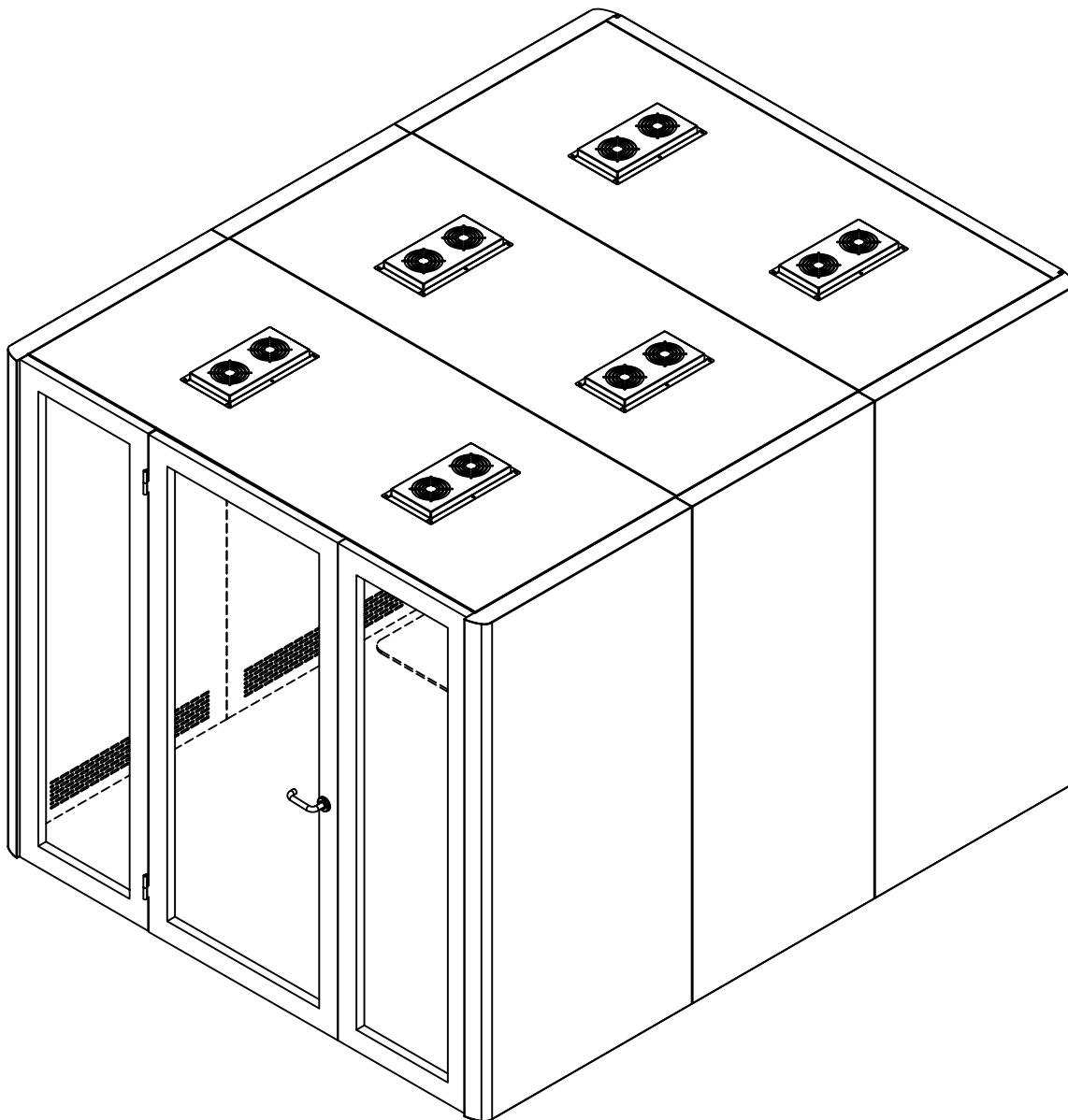

ATTENTION

Please read installation manual carefully before assemble.

First remove the accesory box. Carton number (20)

Follow the carton number when unboxing.

Complete assemble each according to the carton number and proceed to the next.

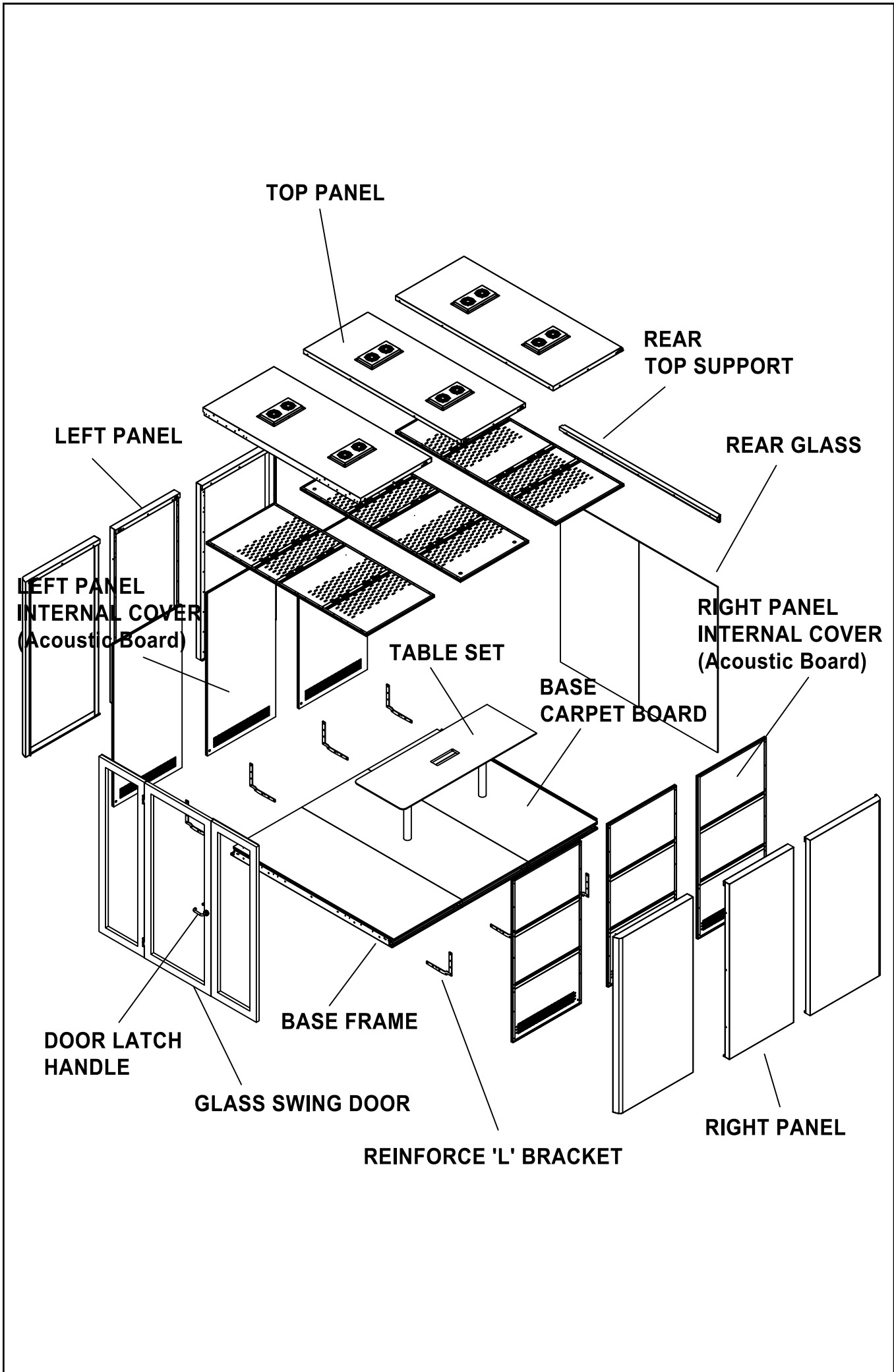

1

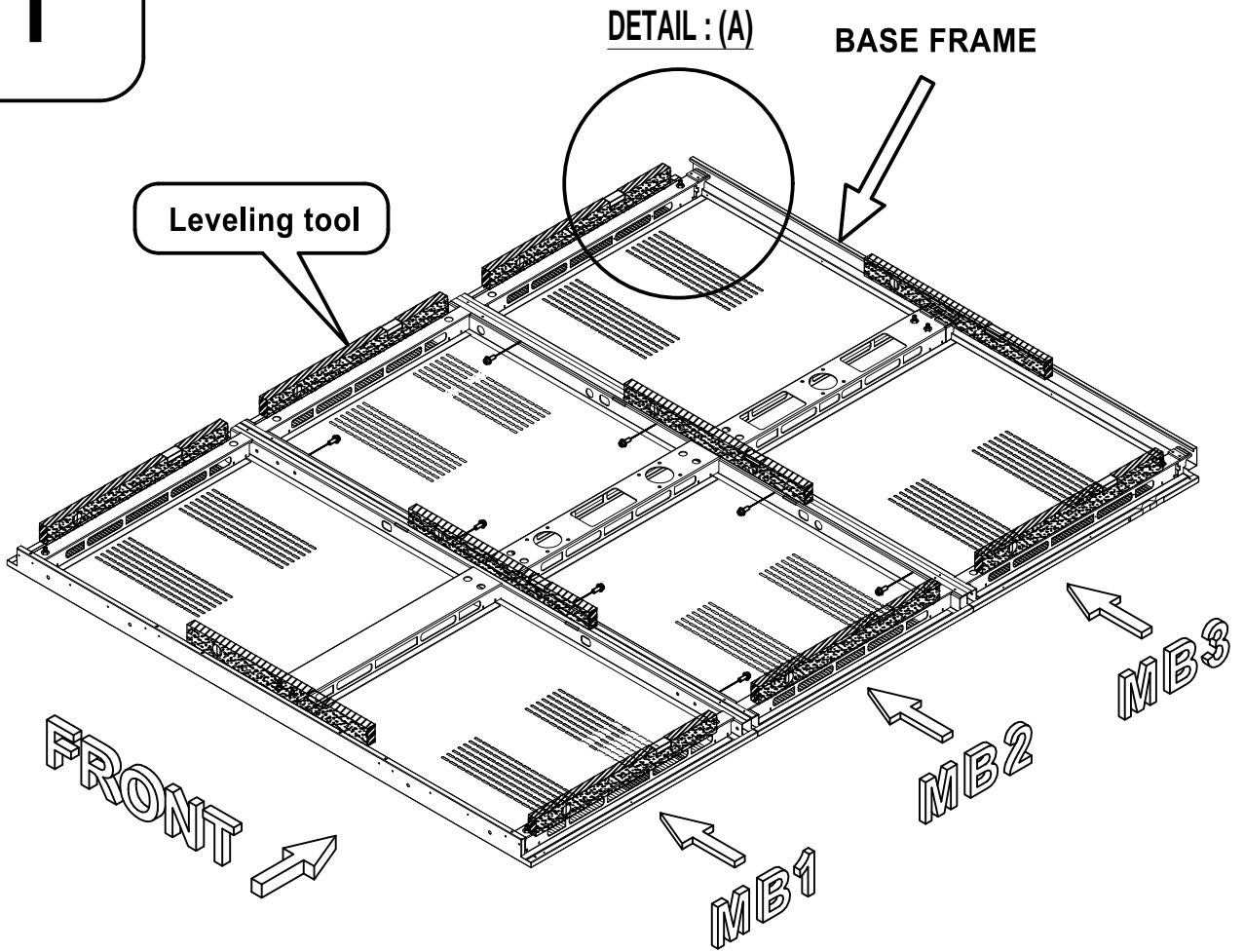

DETAIL : (A)

- Step 1 - Push to final position before setting up the booth
- Step 2 - Adjustable foot cap for leveling
- Step 3 - Level the base before installation

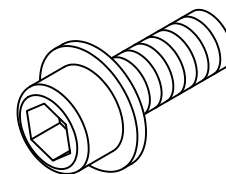
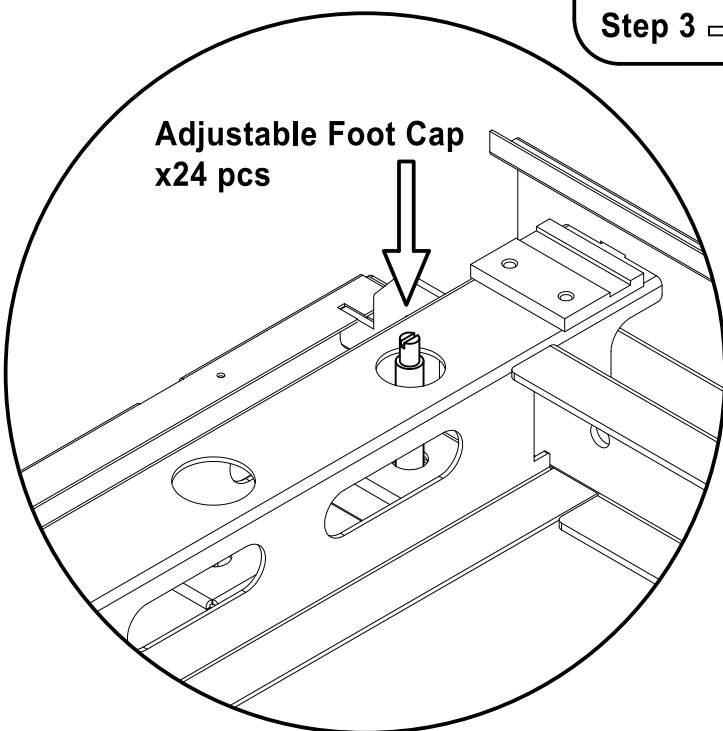

Cap screw with flat washer
(m8 x 20zp)

2

REINFORCE 'L' BRACKET

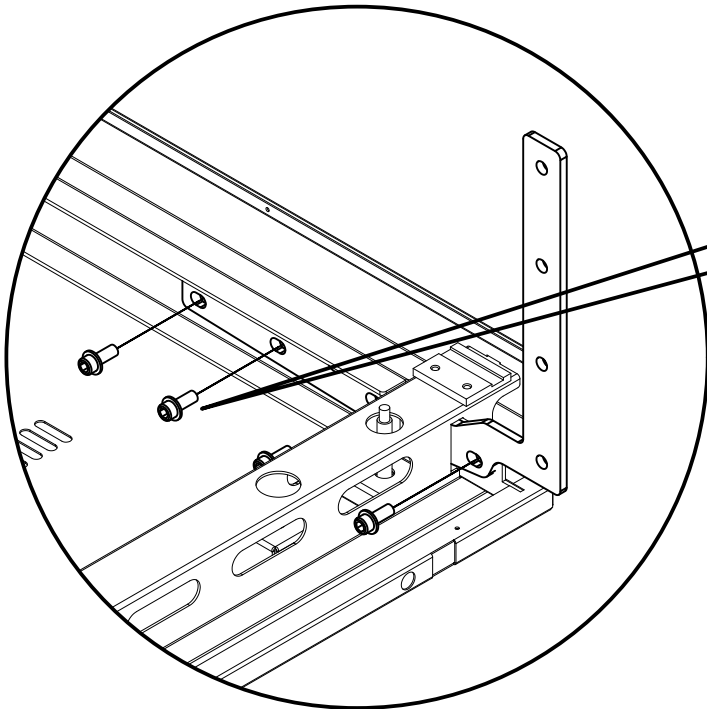
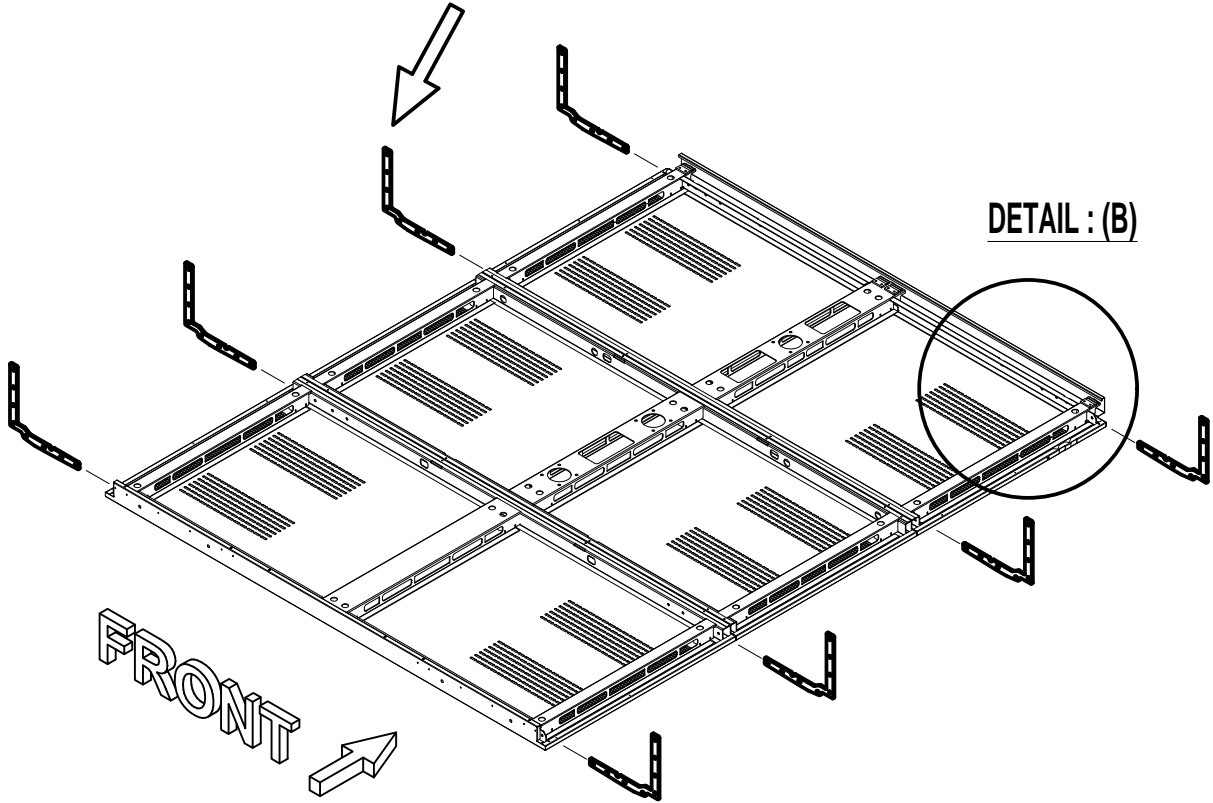

 Do not tighten

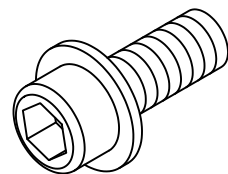

Cap screw with flat washer
(m8 x 20zp)

DETAIL : (B)

3

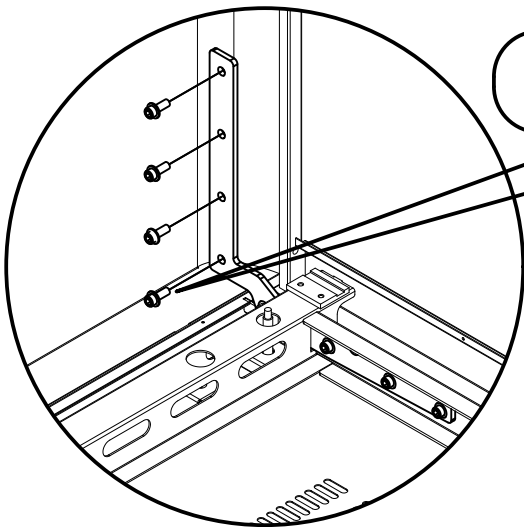
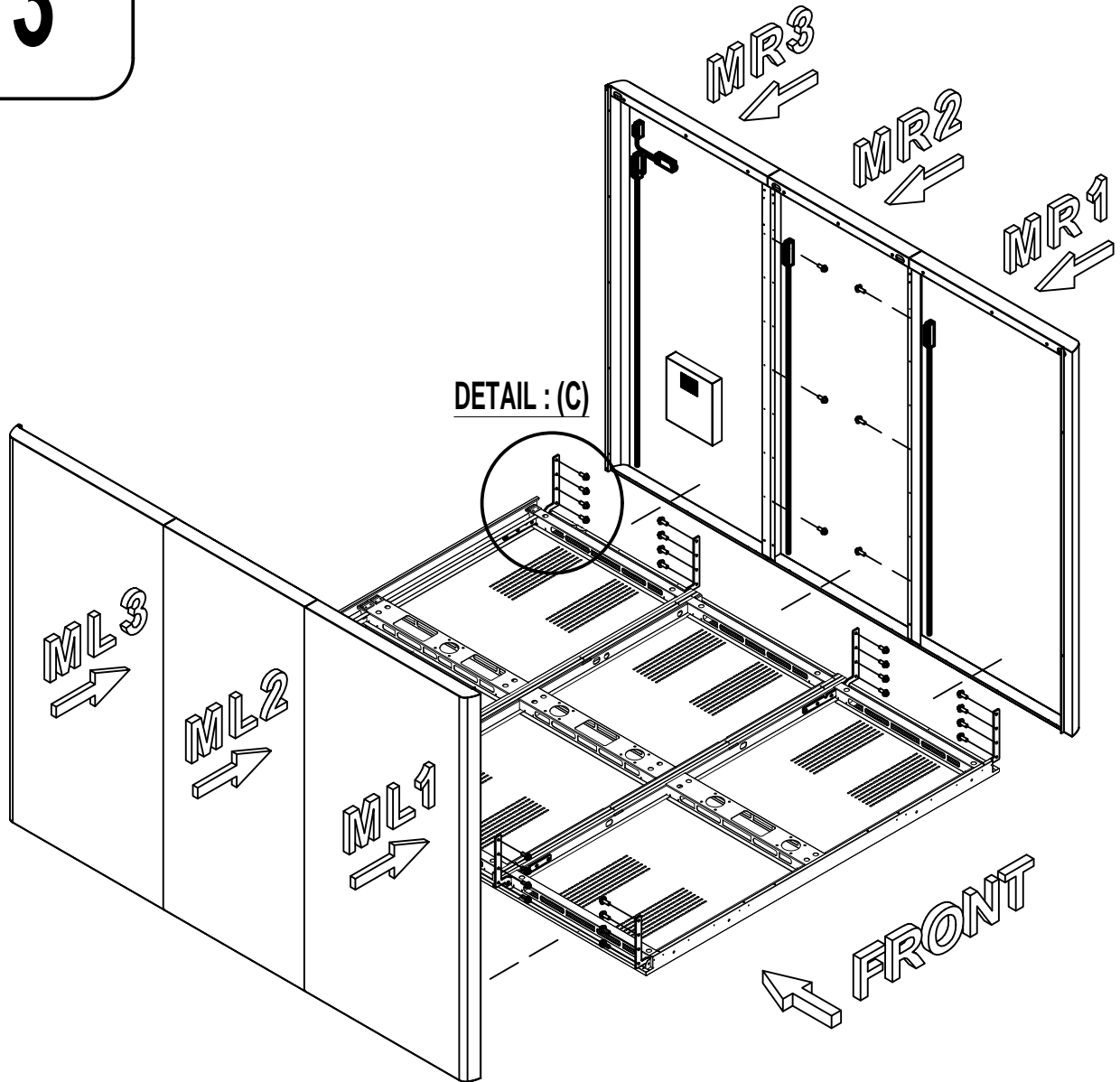

Do not tighten

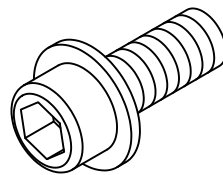

Cap screw with flat washer
(m8 x 20zp)

DETAIL : (C)

4

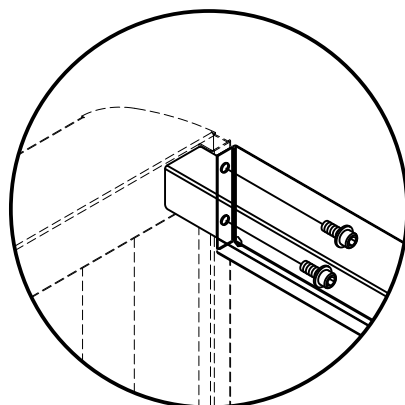
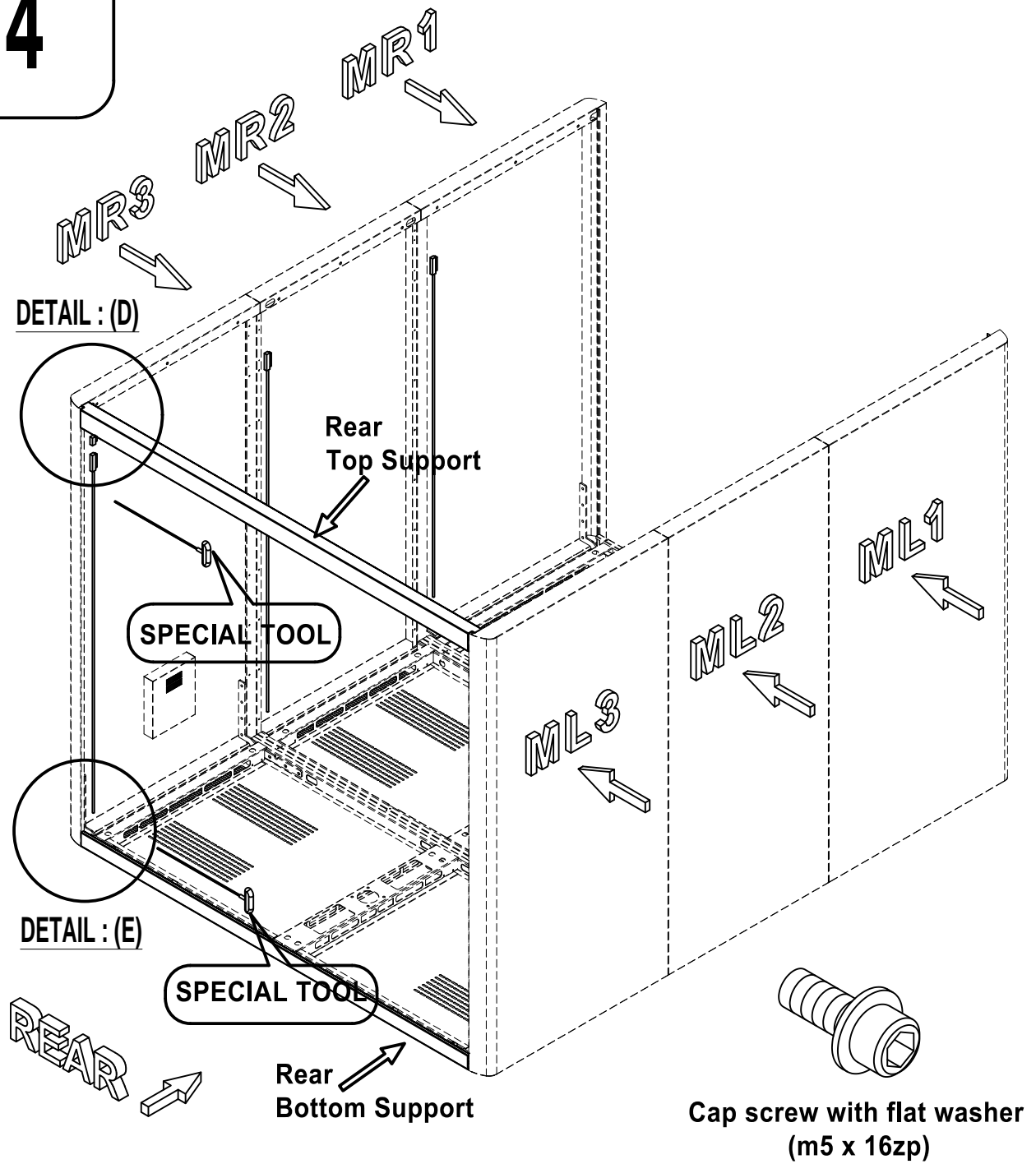

DETAIL : (D)

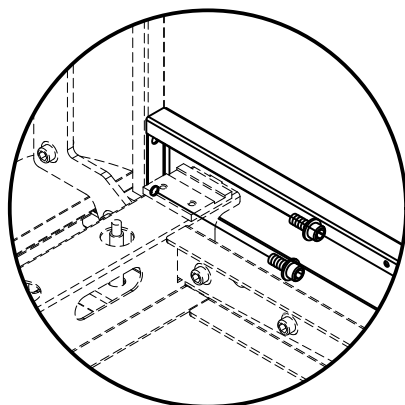

DETAIL : (E)

5

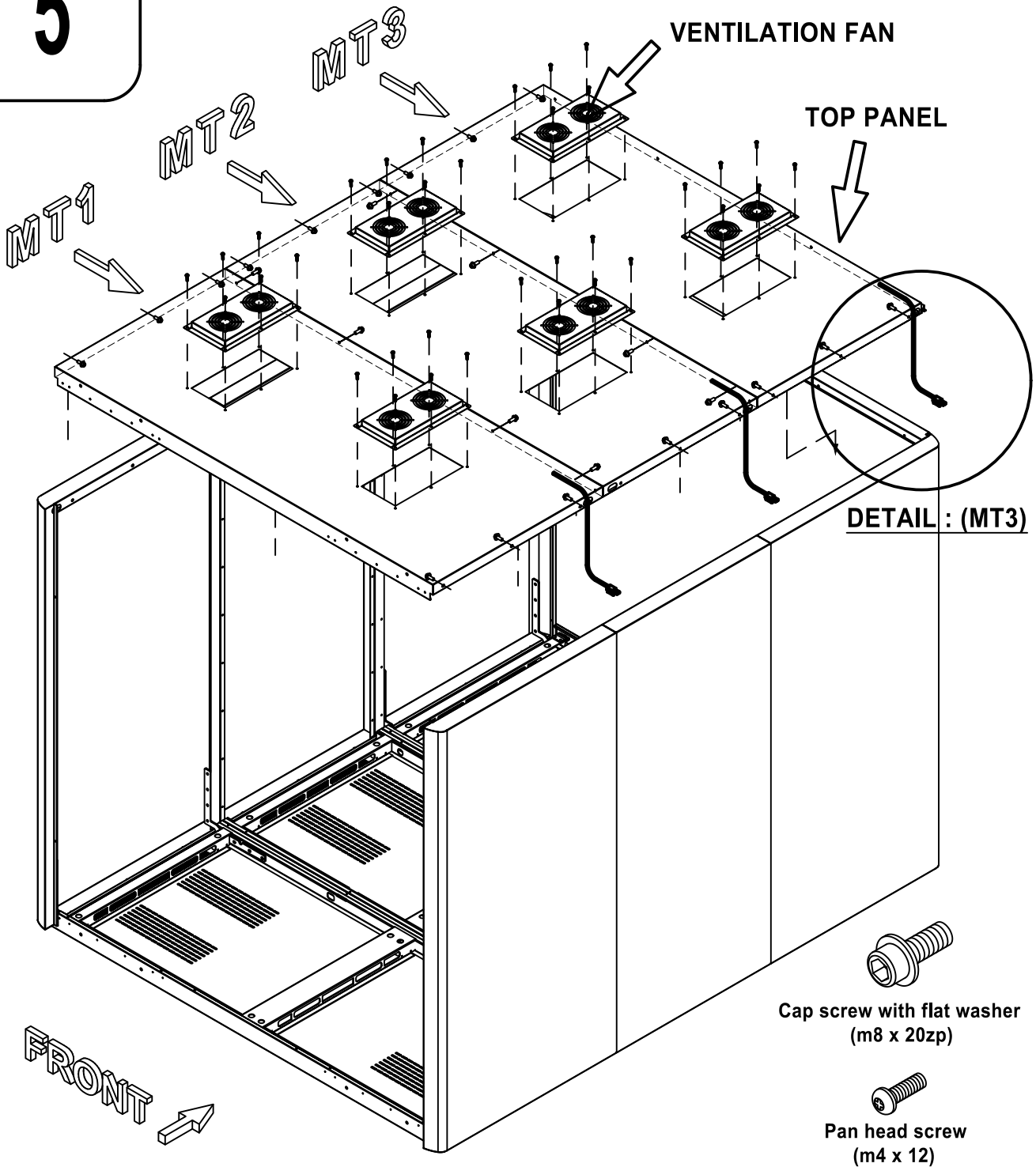

DETAIL: (MT3)

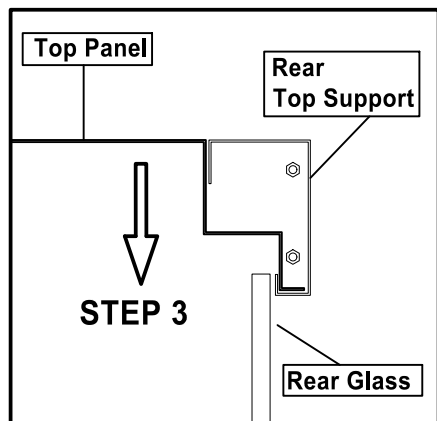
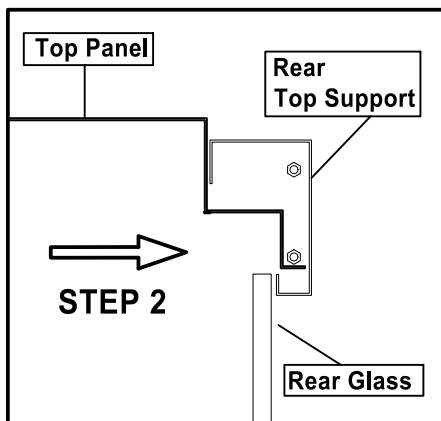
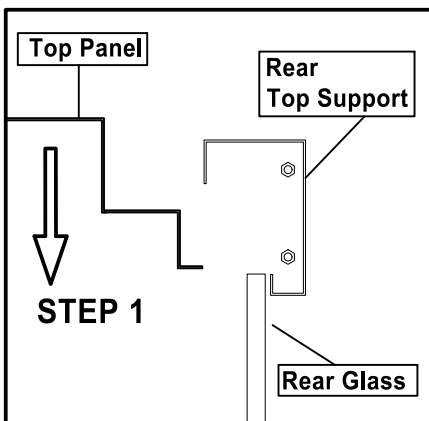

6

**REAR GLASS RUBBER SEAL
(1110mm x 2pcs)**

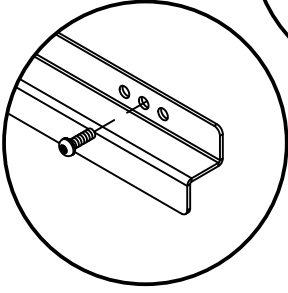
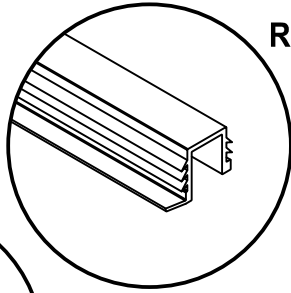

**GLASS HOLDER BRACKET
(395mm x 15pcs)**

**REAR GLASS
(x2pcs)**

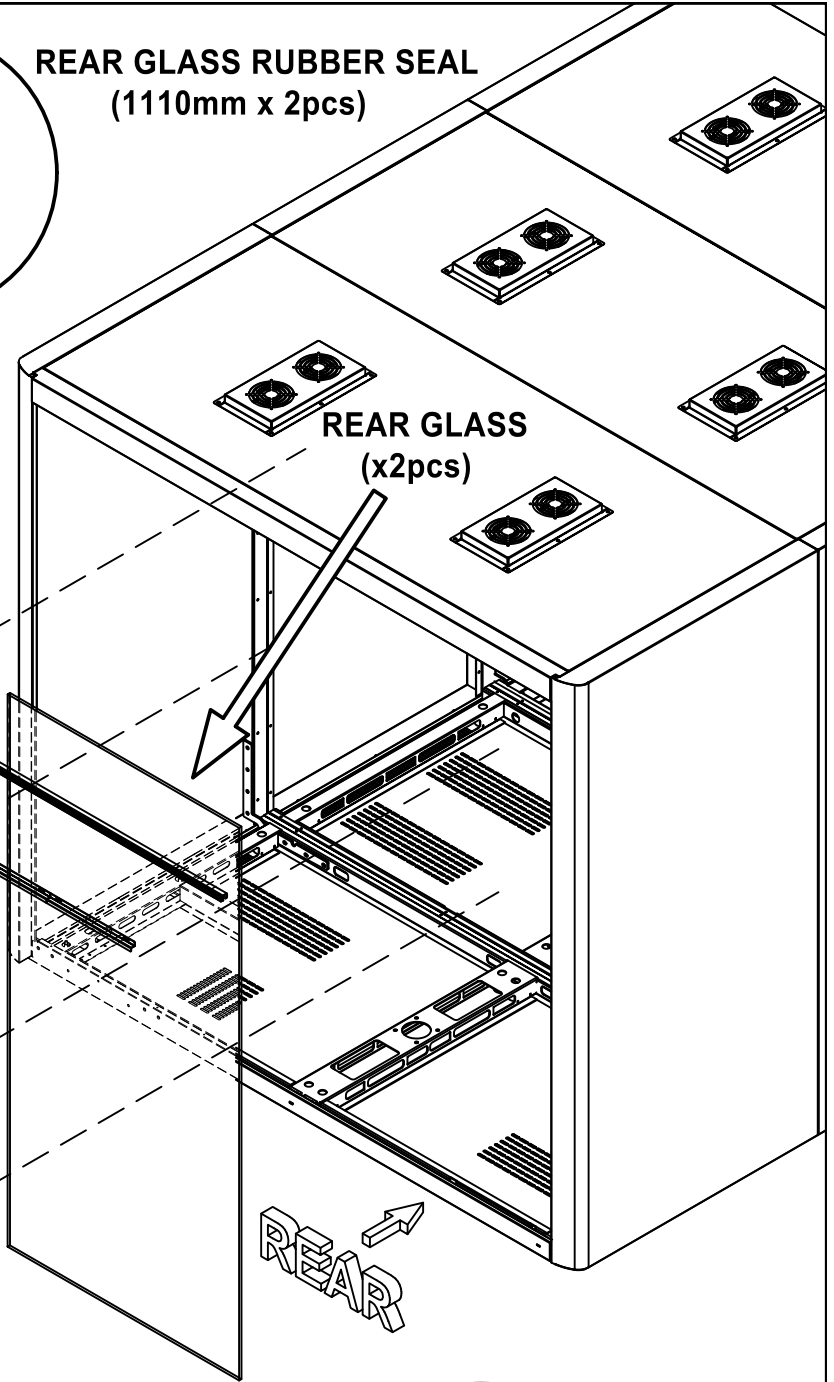

REAR →

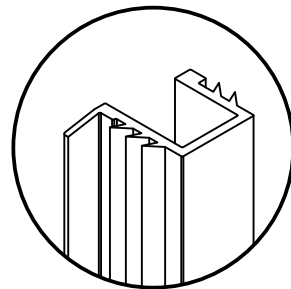

**REAR GLASS RUBBER SEAL
(1990mm x 2pcs)**

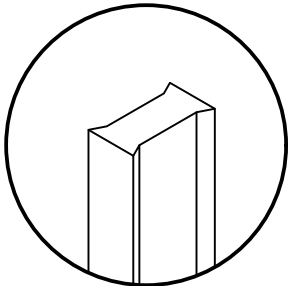

**REAR GLASS 'I' JOINT
(2025mm x 1pc)**

7

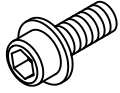

Cap screw
with flat washer
(m8 x 20zp)



Pan head screw
(m4 x 12)

DETAIL : (F)

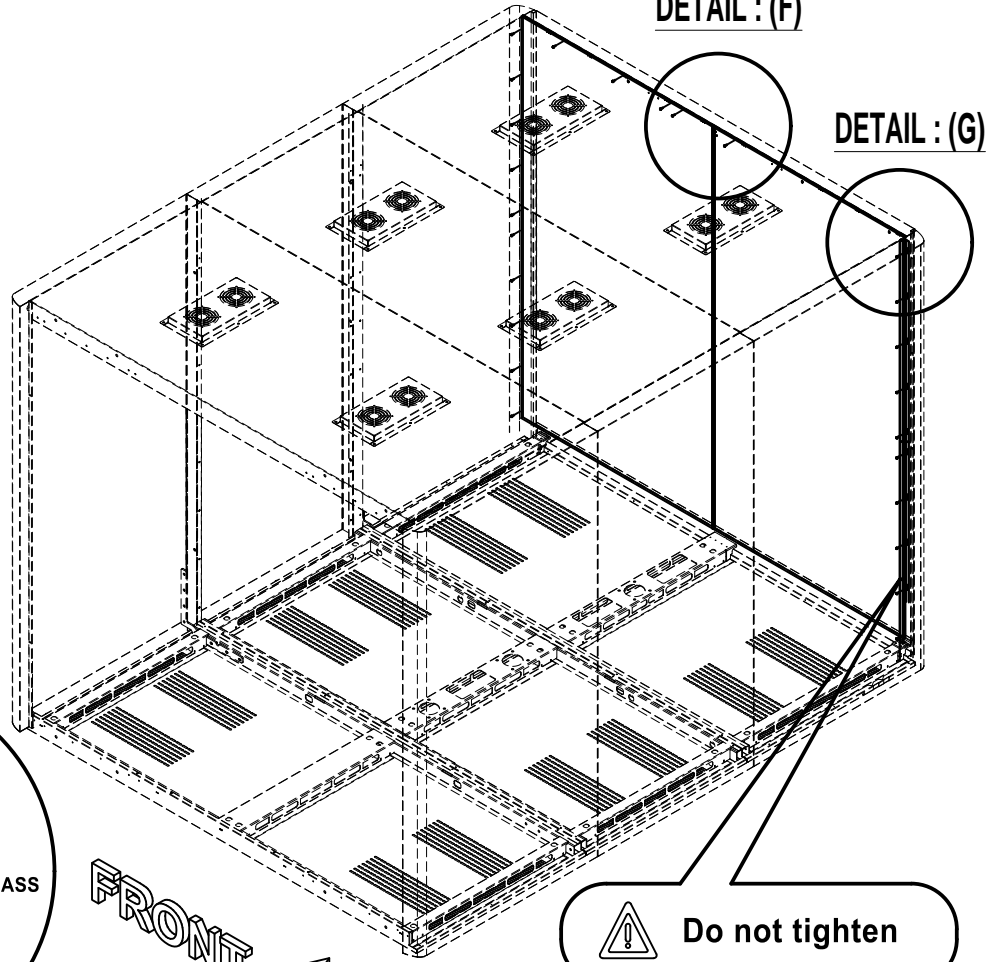
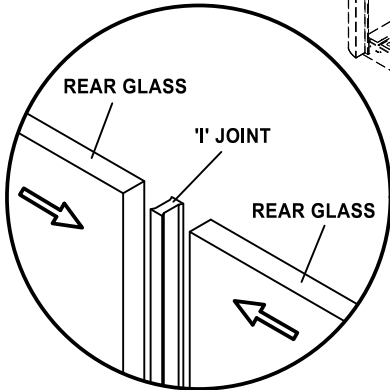

DETAIL : (G)

STEP 1

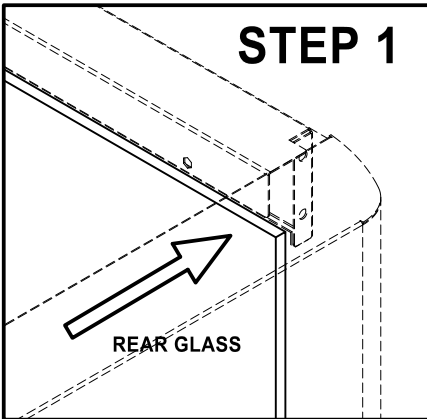

STEP 2

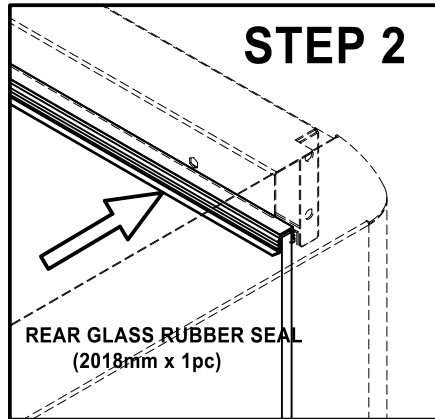

STEP 3

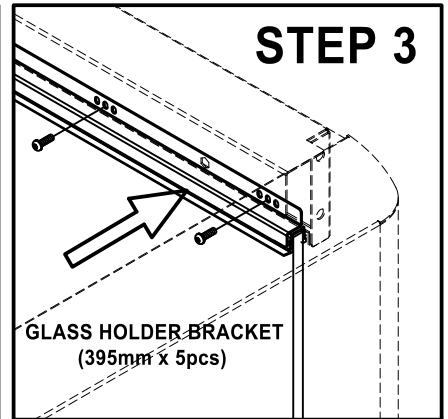

STEP 4

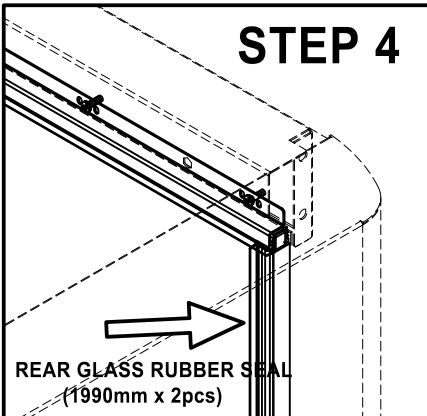

STEP 5

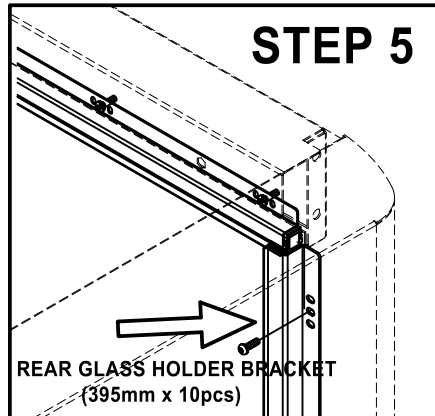

Do not tighten

8

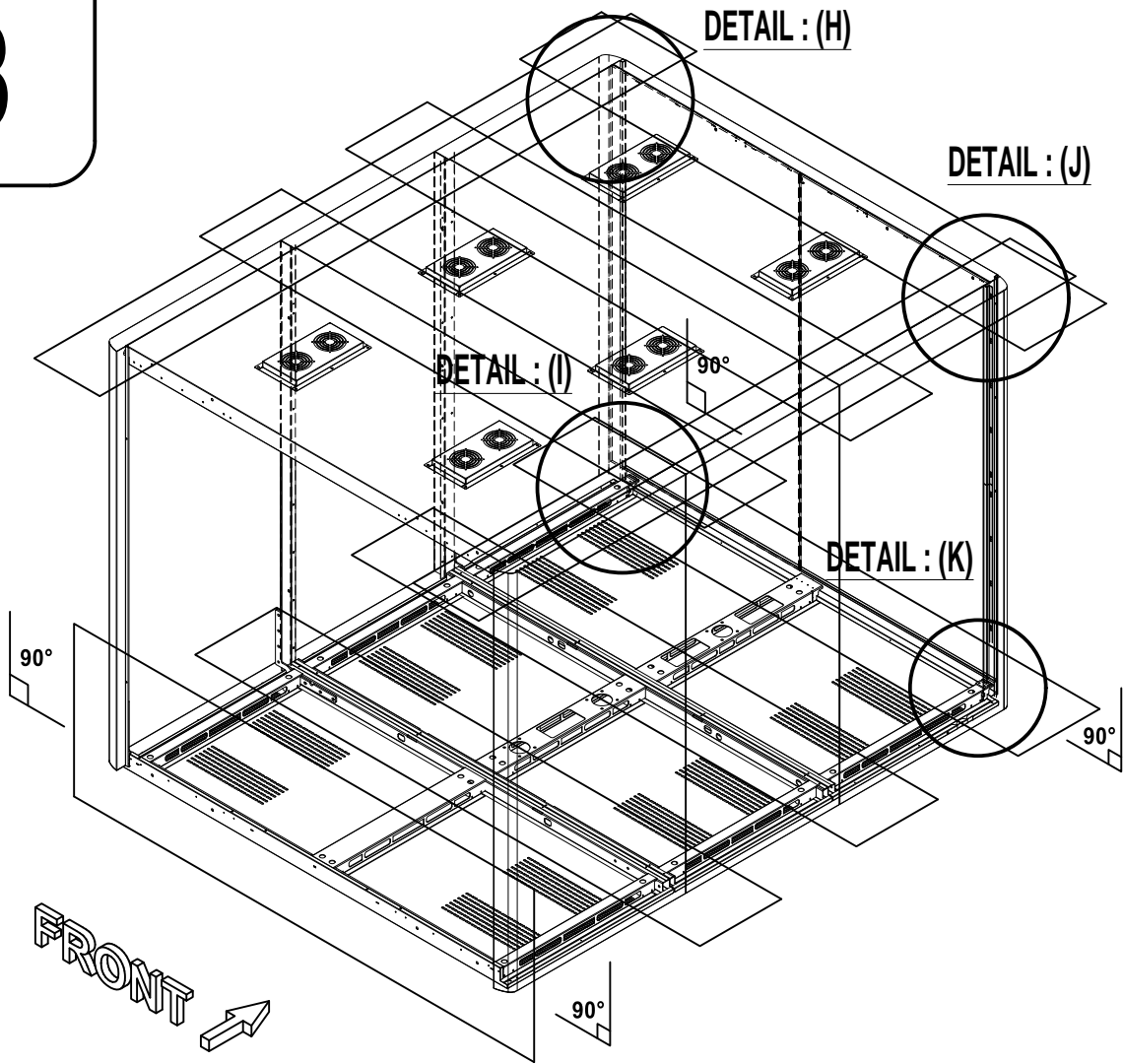

DETAIL : (H, I, J & K)

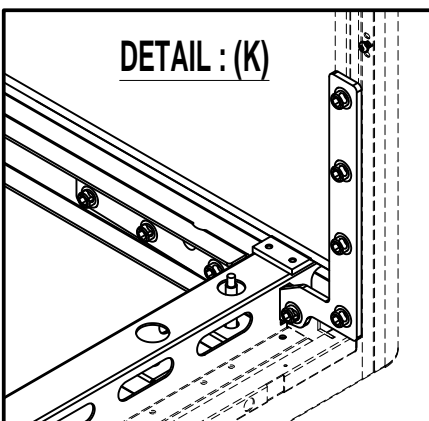
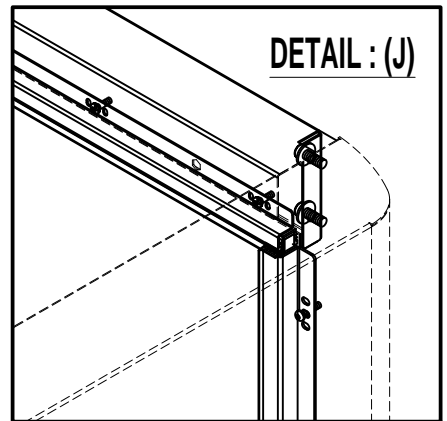
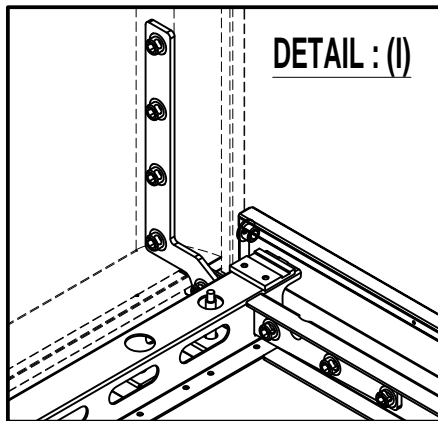
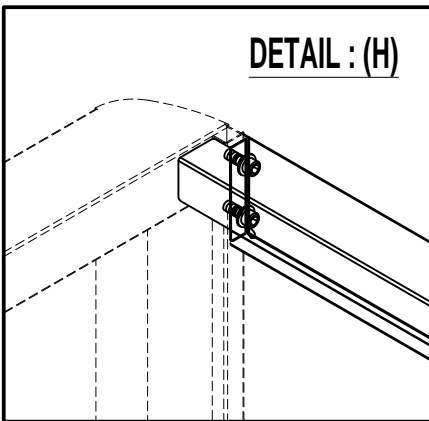

STEP 1 □ Check Leveling

STEP 2 □ Tighten all screw to ensure steady structure

9

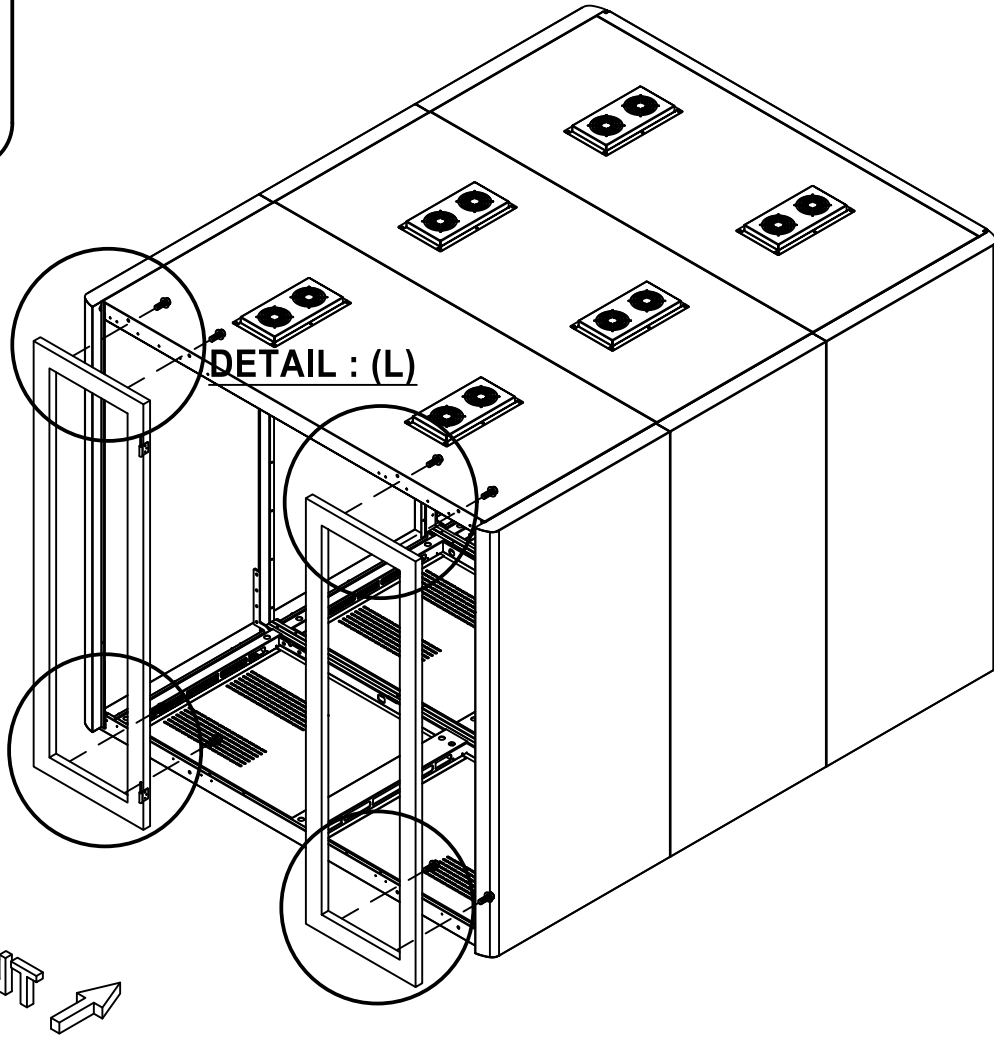

DETAIL : (L)

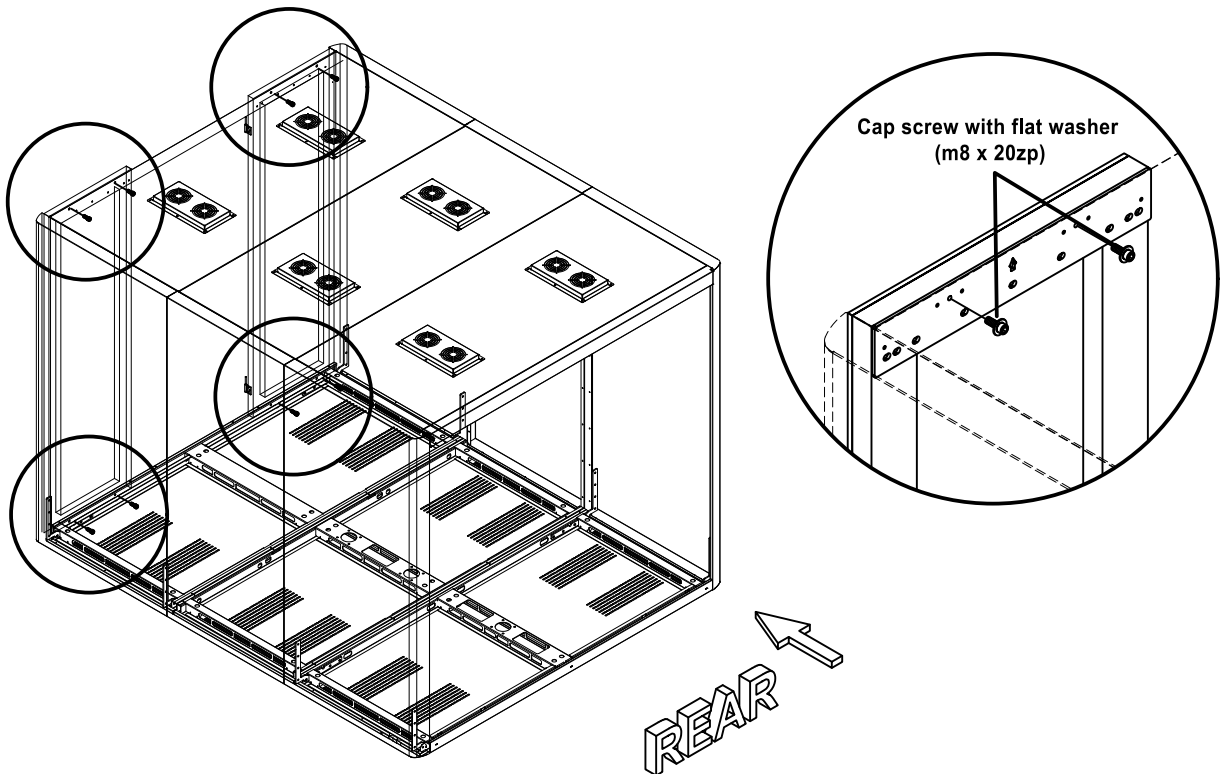

10

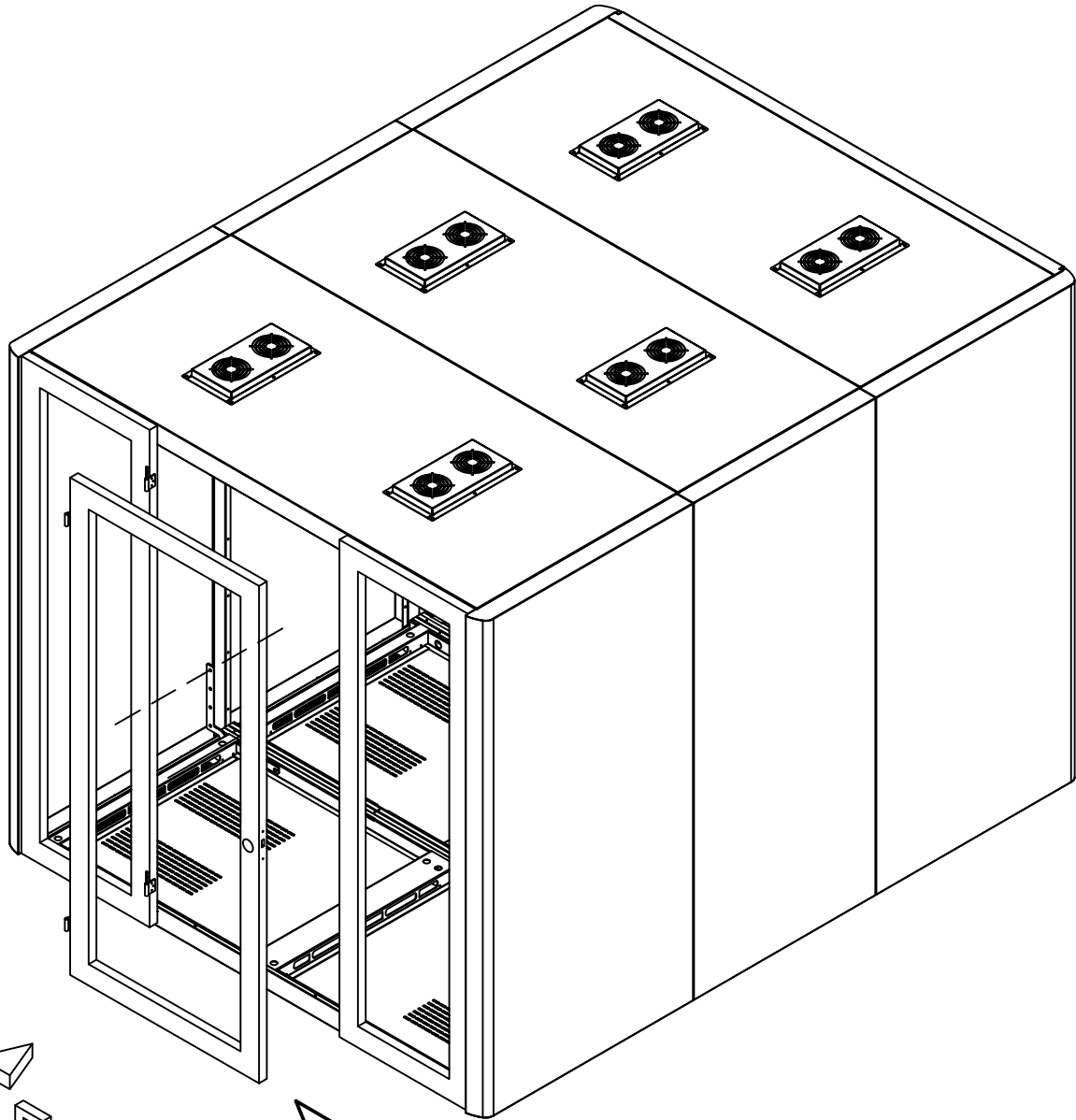

↑
FRONT

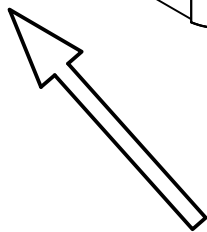

GLASS SWING DOOR

11

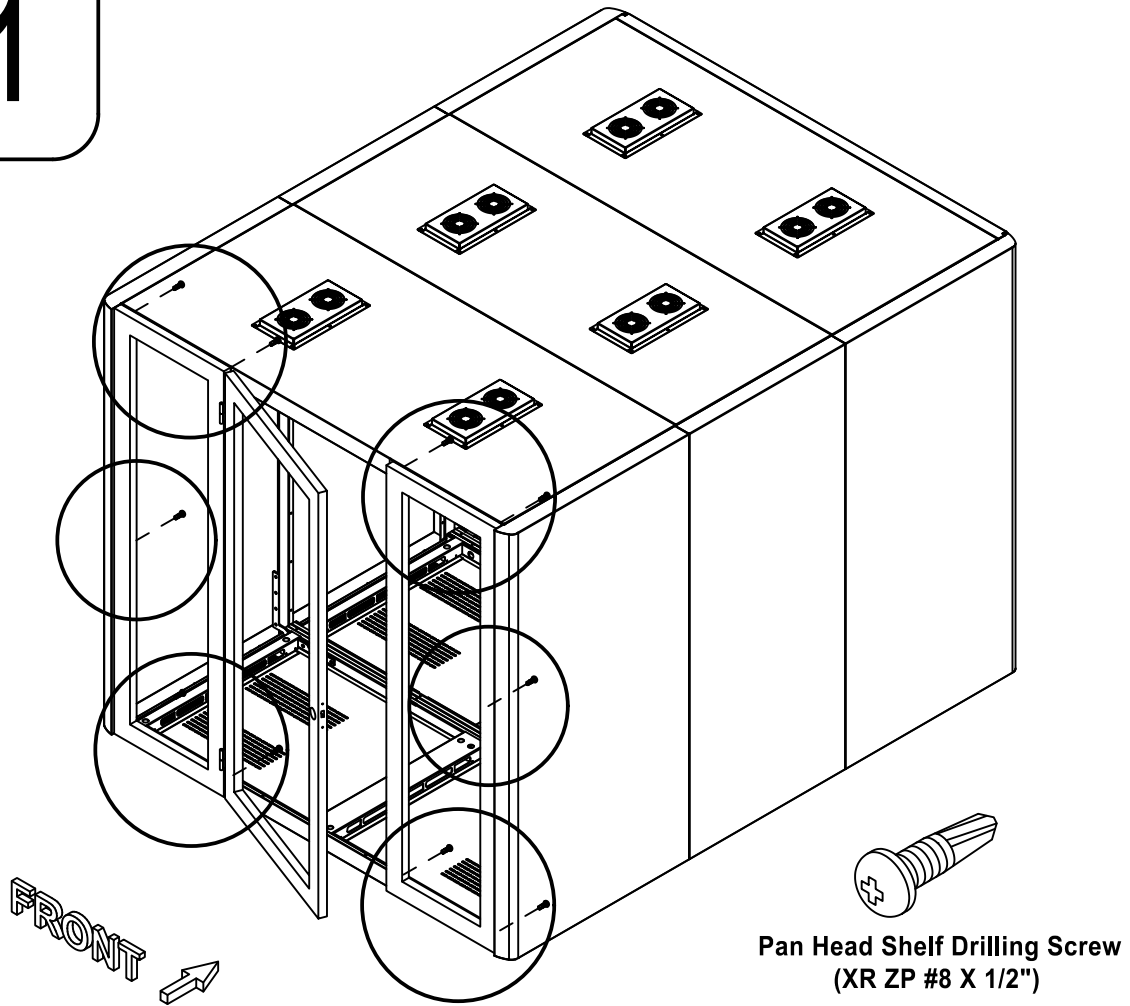

DETAIL : (M)

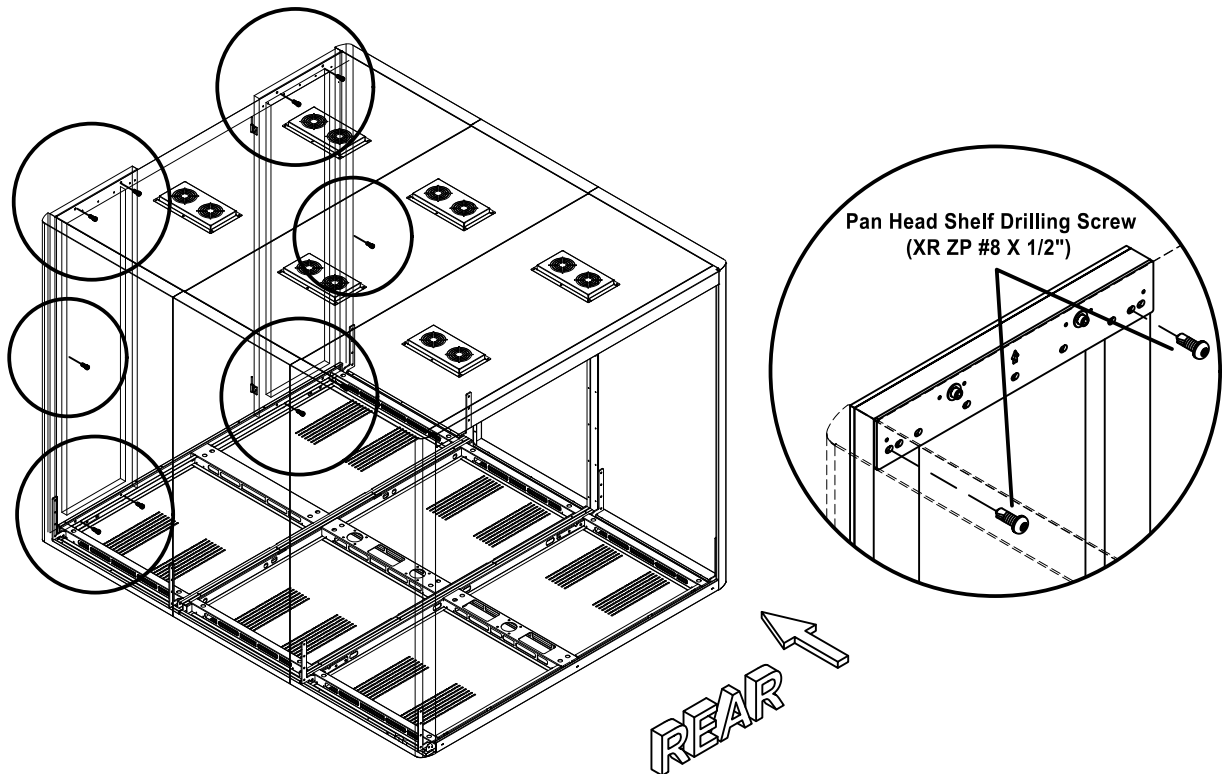

12

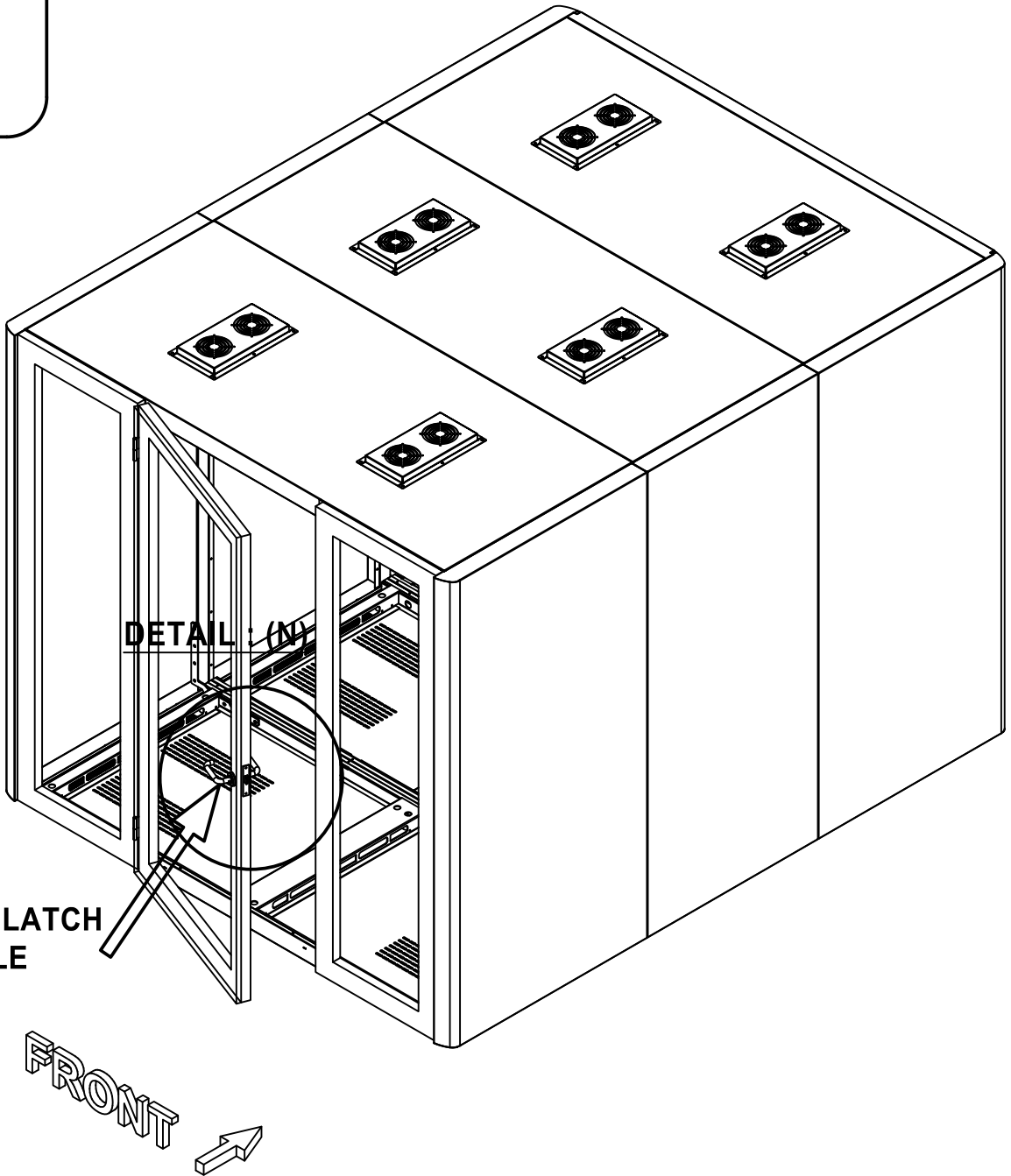

DETAIL : (N)

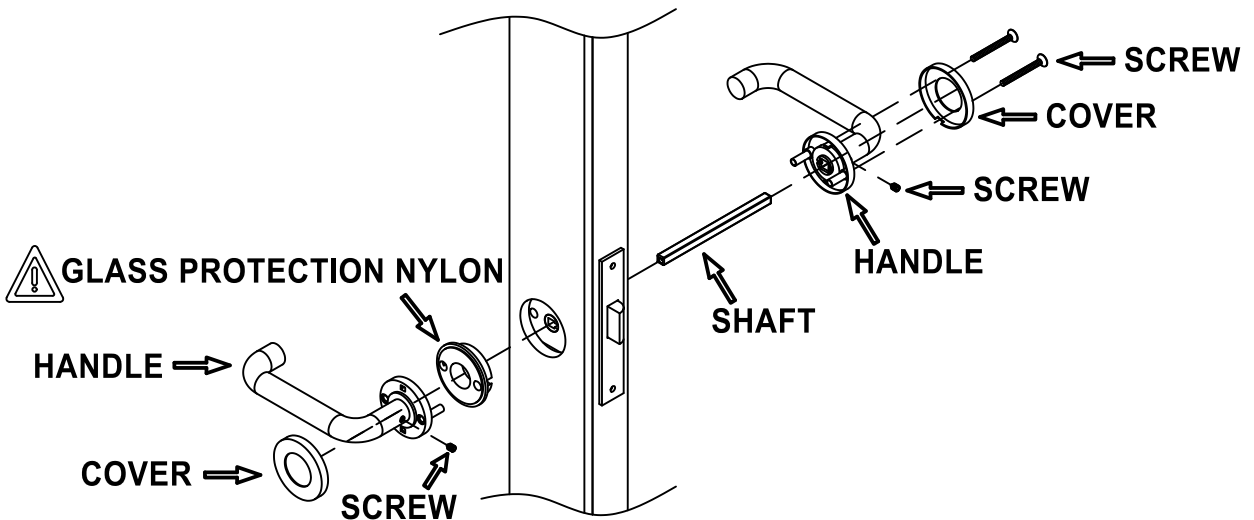

DETAIL : (O)

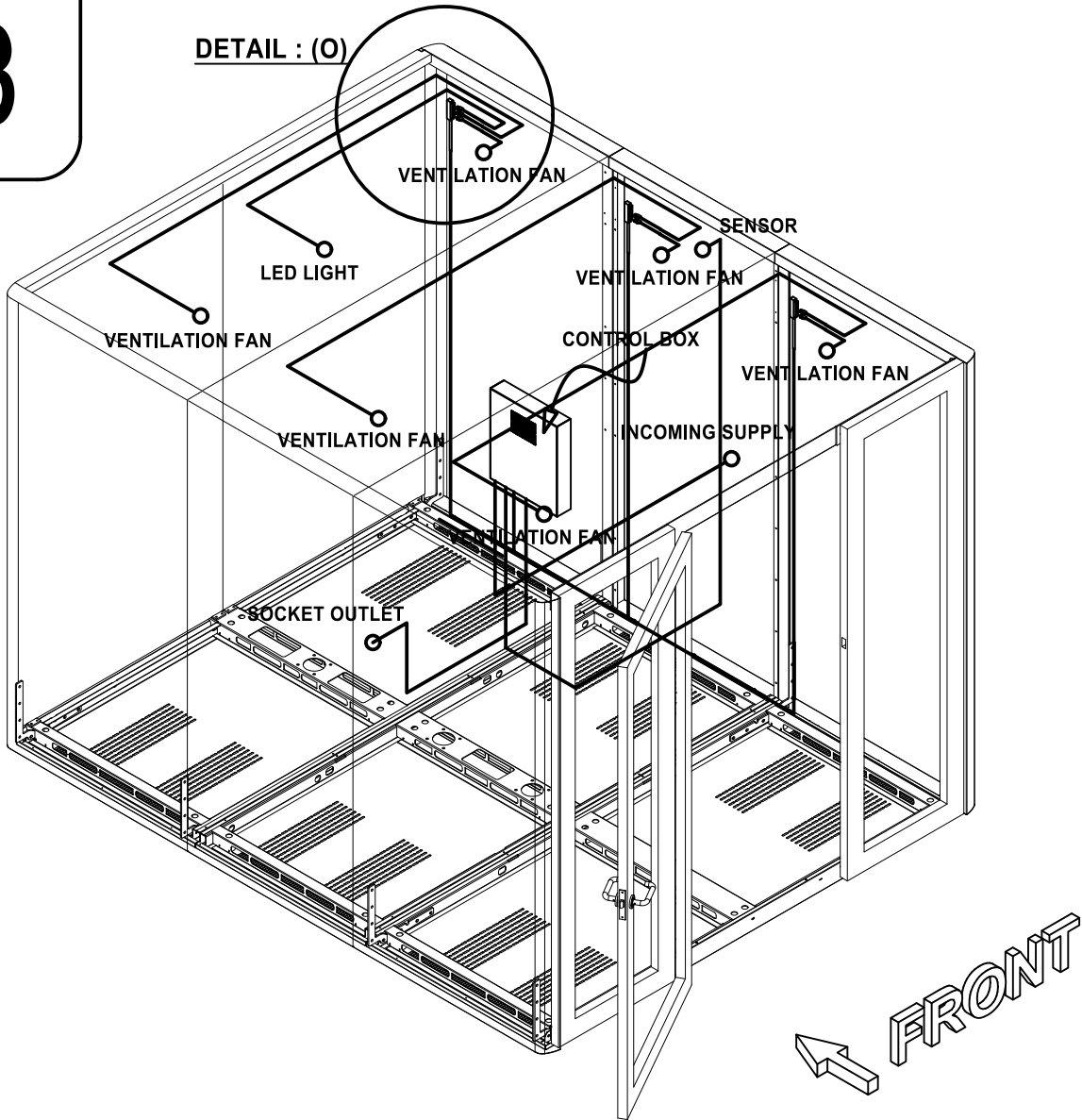

DETAIL : (O)

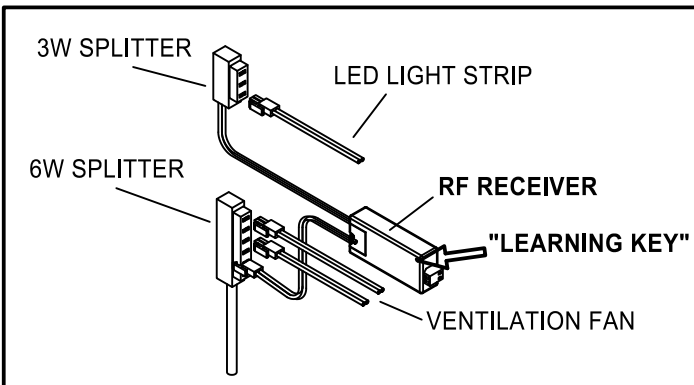

Before the first use, please open the battery cover and remove the *protective film*

PAIR WITH RF RECEIVER

- 1- Click "learning key" on RF receiver
- 2- Click ON or OFF button on RF remote
- 3- LED lights connected with the receiver will flicker once
- 4- The receiver is paired with remote successfully

HOW TO DELETE THE PAIRING

- 1- Press and hold down "learning key" on the RF receiver for over 3 seconds until connected LED lights flicker twice, which means the pairing deleted successfully.

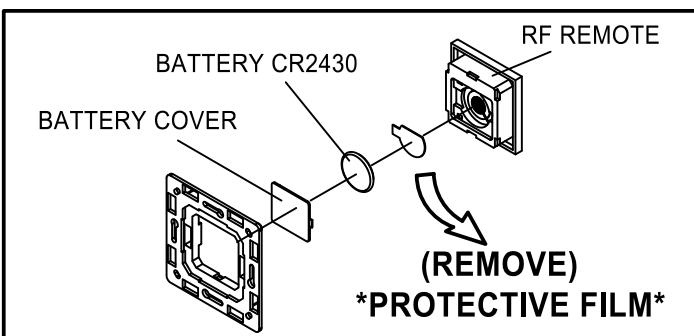

14

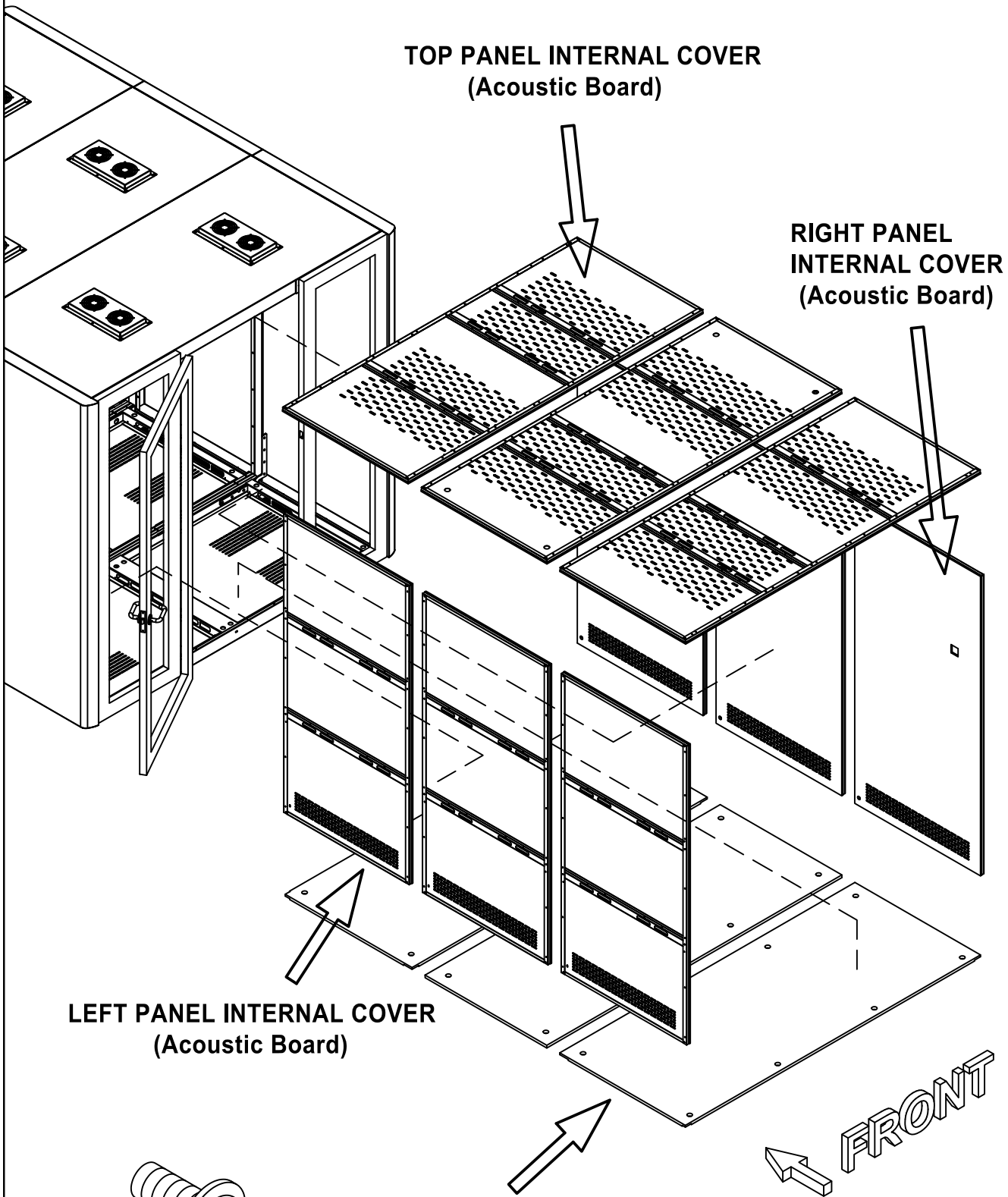

Cap screw with flat washer
(m5 x 16zp)

15

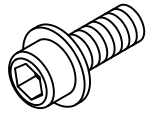
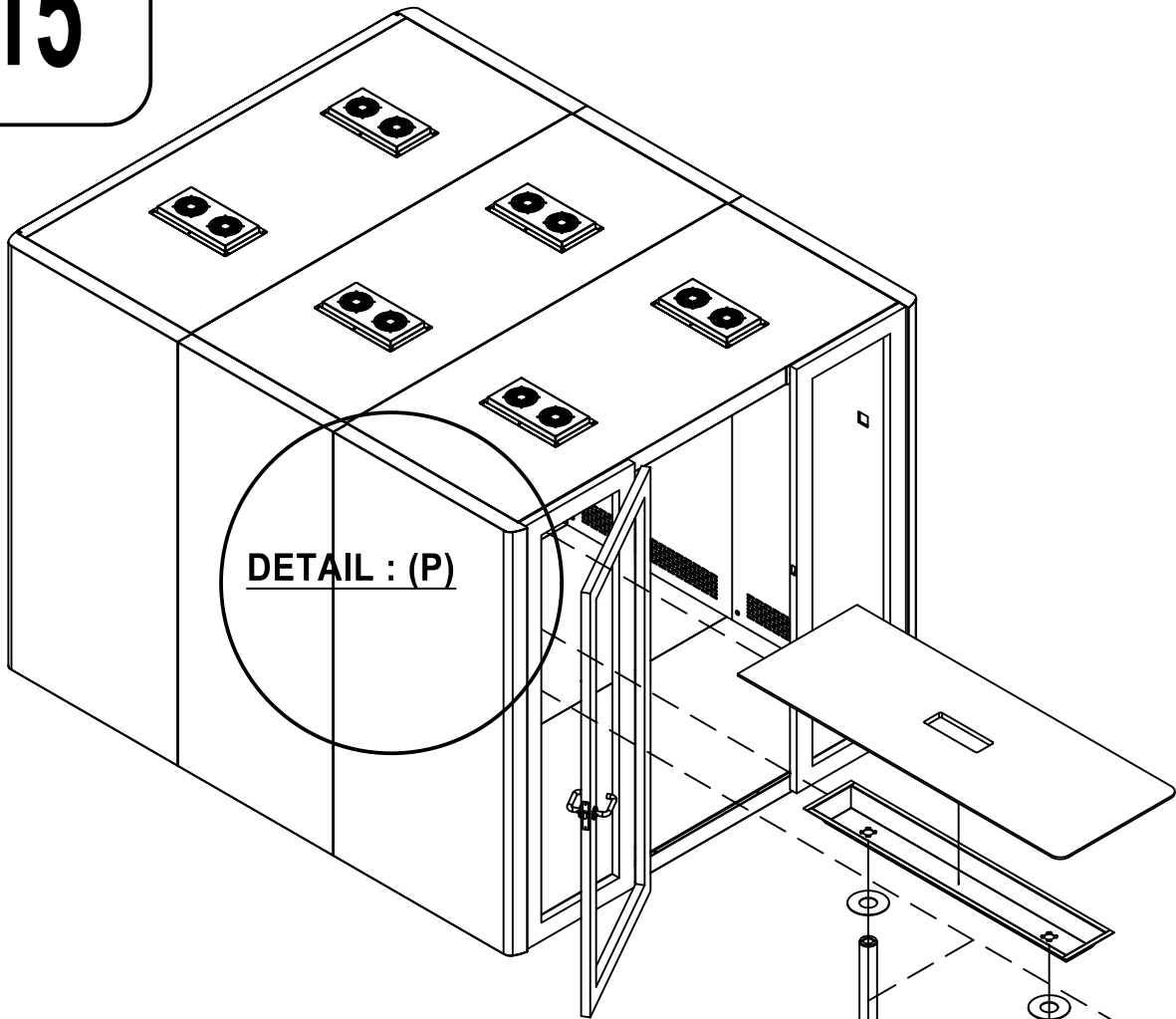

Cap screw with flat washer
(m8 x 20zp)



JCBC SCREW
(m6 x 16 ZP)

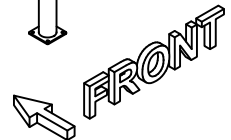

DETAIL : (P)

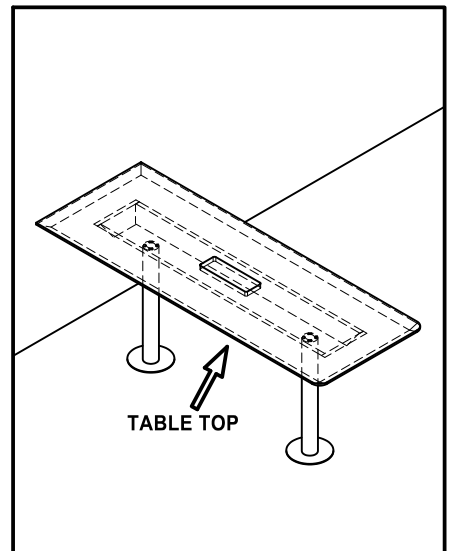
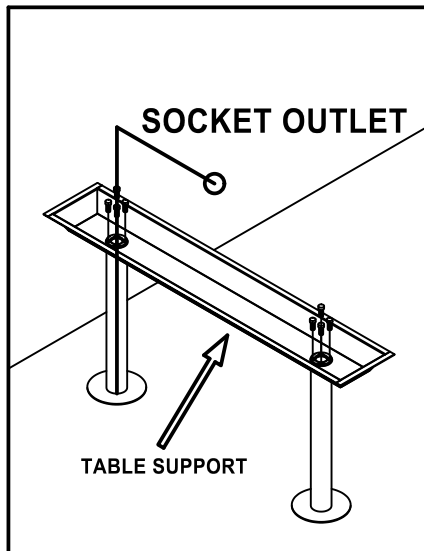
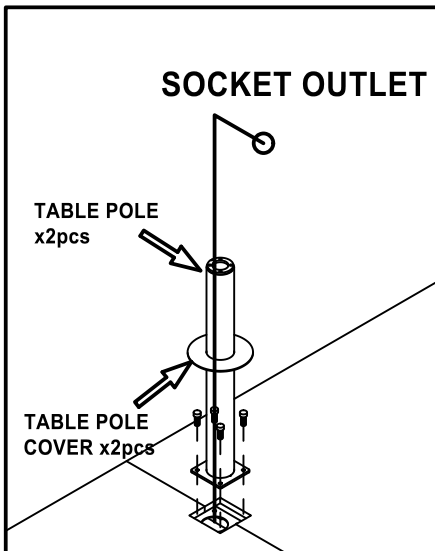

16

ALU FIXED GLASS SEAL
(2000mm x 2pcs)

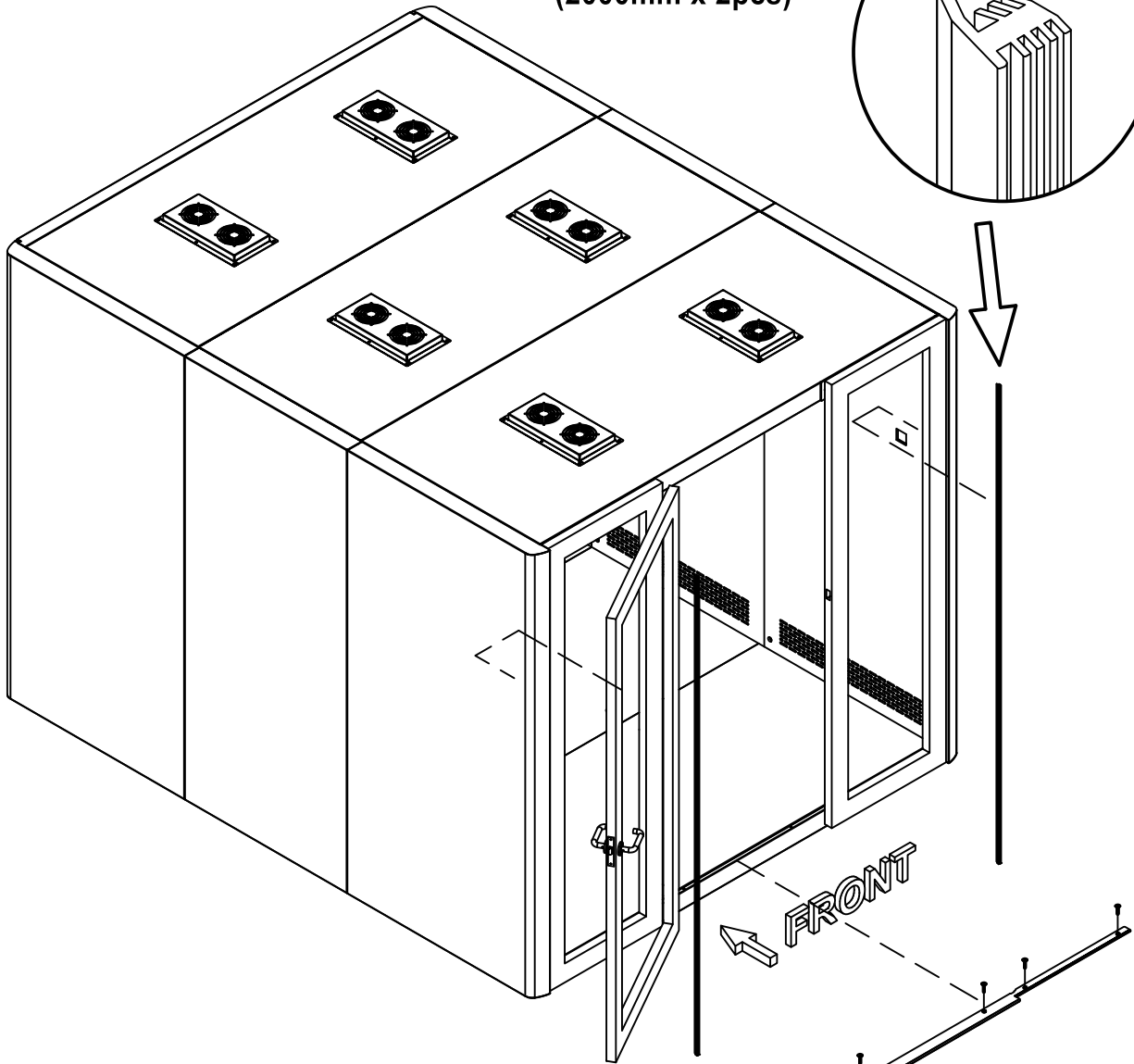
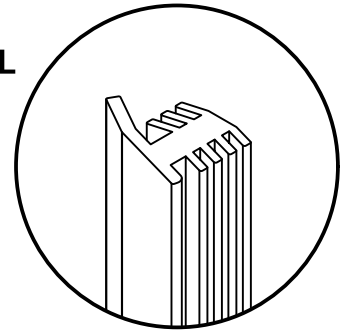

FRONT

SIDE STEP

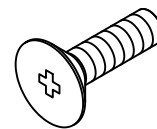

S/S A2 CSK HD MC SCREW
(m5 x 12)

17

