

ANABEI

Assembly Guide

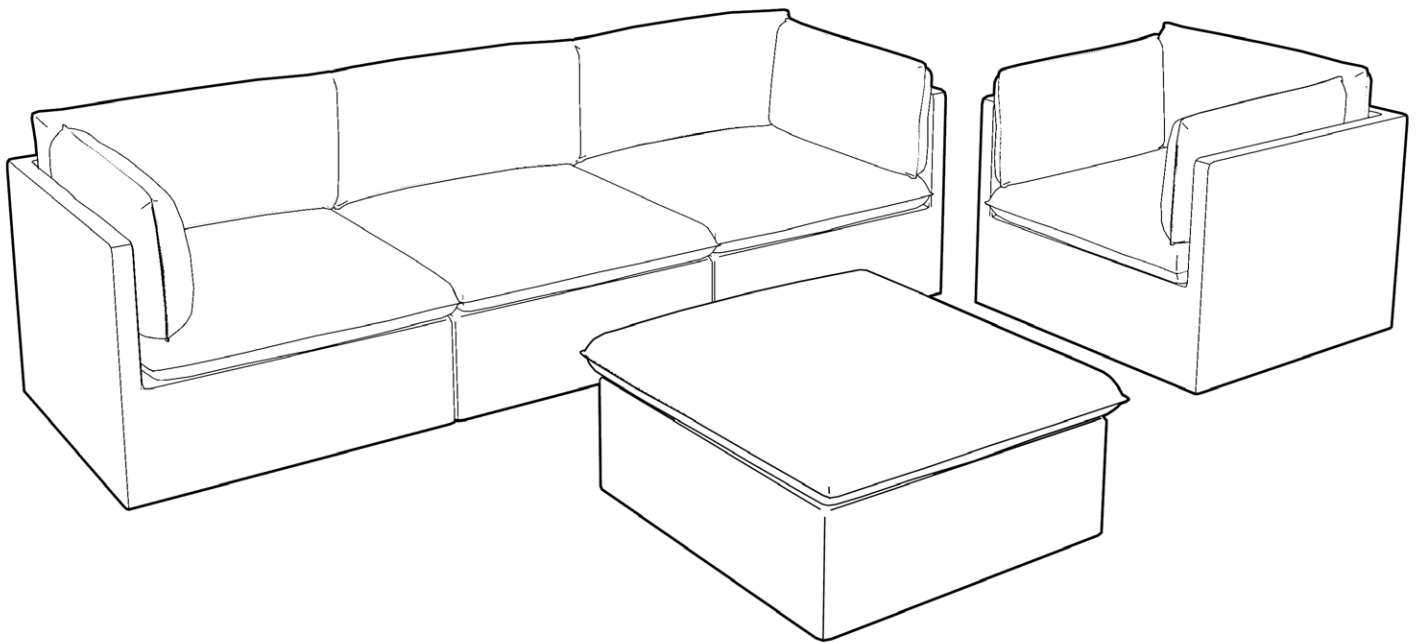

For video assembly guide,
scan the QR code:



or visit: assembly.anabei.com

Included Parts

The parts shown here are all the available options. The parts you have will depend on your custom order.

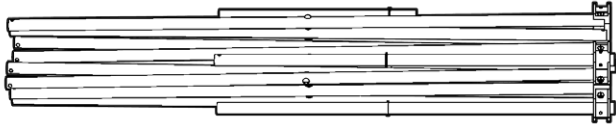

Primary Frame

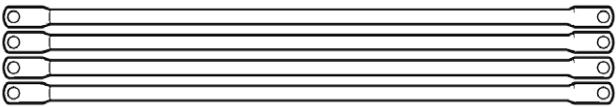

Frame Cross Braces

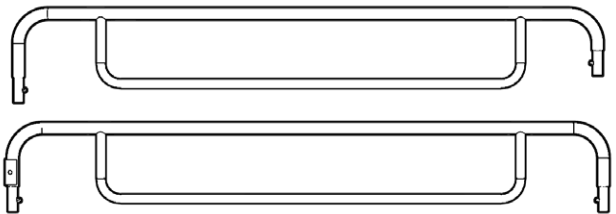

Back/Arm Cross Bars

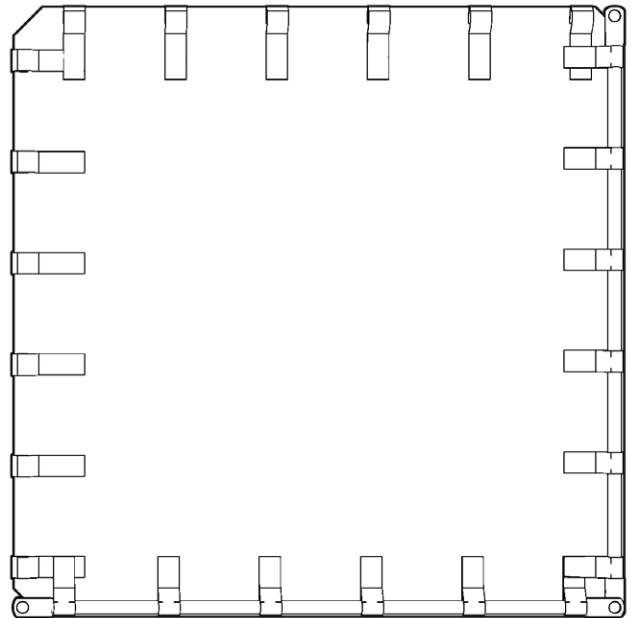

Seat Deck

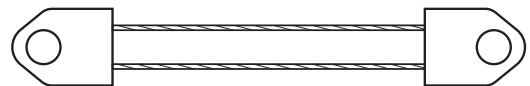

Deck Support Cable

Hardware

NOTE: Armchair requires no hardware

Ottoman

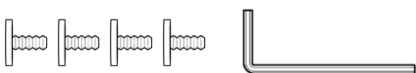
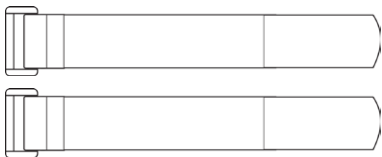

2x Frame Straps
4x Frame Screws
1x Allen Key

Armless Chair

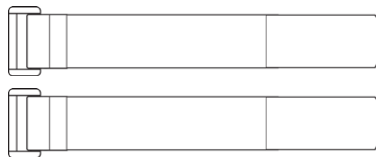

2x Frame Straps
2x Frame Screws
1x Allen Key

Corner / End Chair

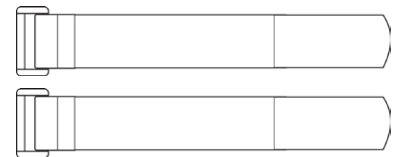

2x Frame Straps
1x Frame Screws
1x Allen Key

Step 1: Assemble Frame

Before you begin, be sure that you're assembling on a non-abrasive surface, such as carpet or flattened cardboard.

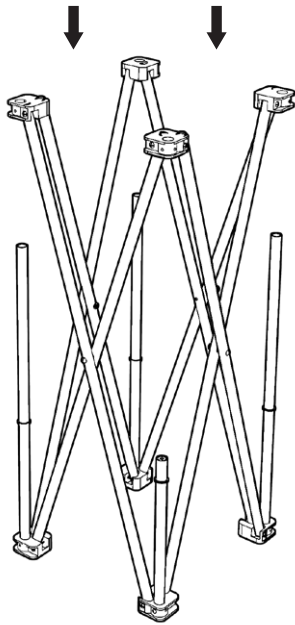

With the loose uprights facing up, press down to expand the primary frame assembly.

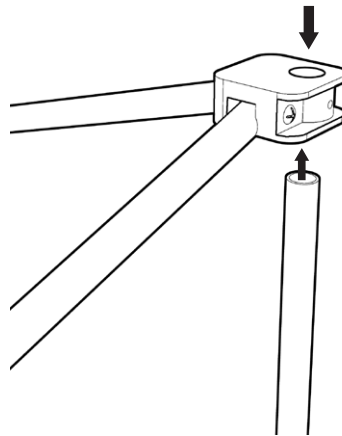

Guide the loose upright poles through the holes on the frame ends.

Push the upright poles through the holes on the frame ends until they rest completely on the frame stops.

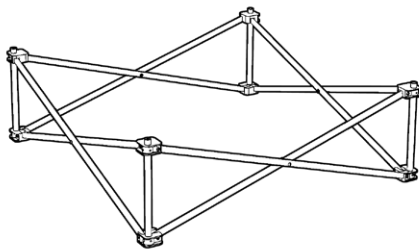

Ottoman

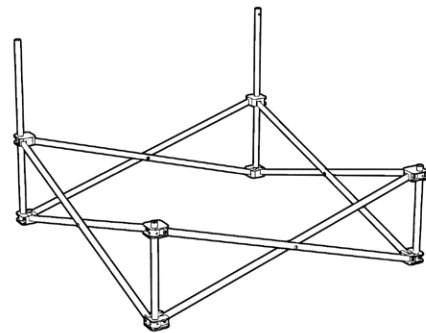

Armless Chair

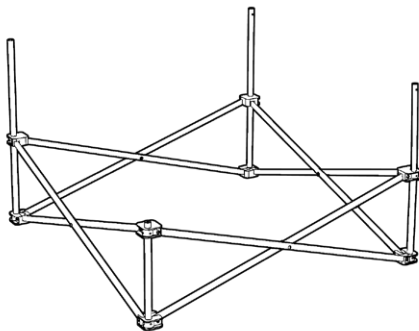

Corner / End Chair

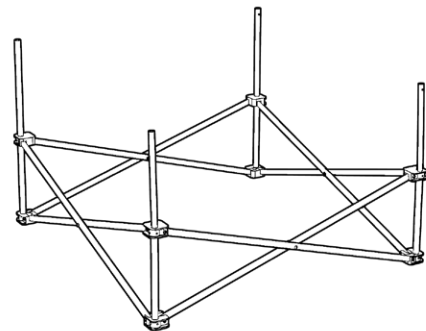

Arm Chair

Step 2: Attach Cross Braces

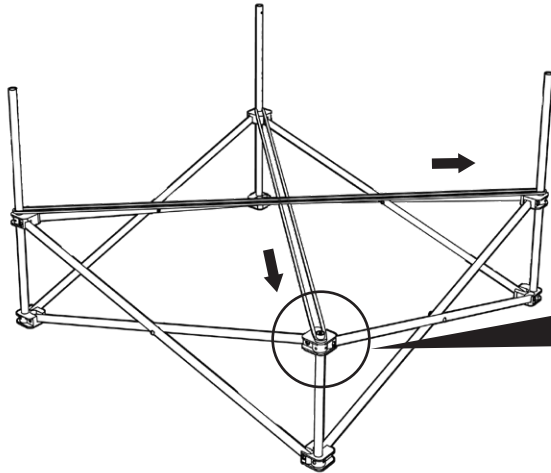

Place the Deck Support Cables over the uprights from corner to corner.

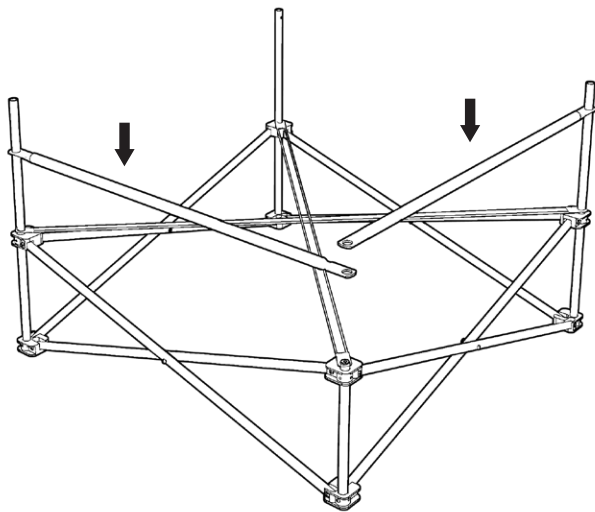

Take two of the cross braces and place them on two adjoining sides as shown.

Slide the cross braces over the extended uprights.

Insert a screw in the top of the frame where there are no extended uprights to secure the cross braces.

Tighten with the Allen Key.

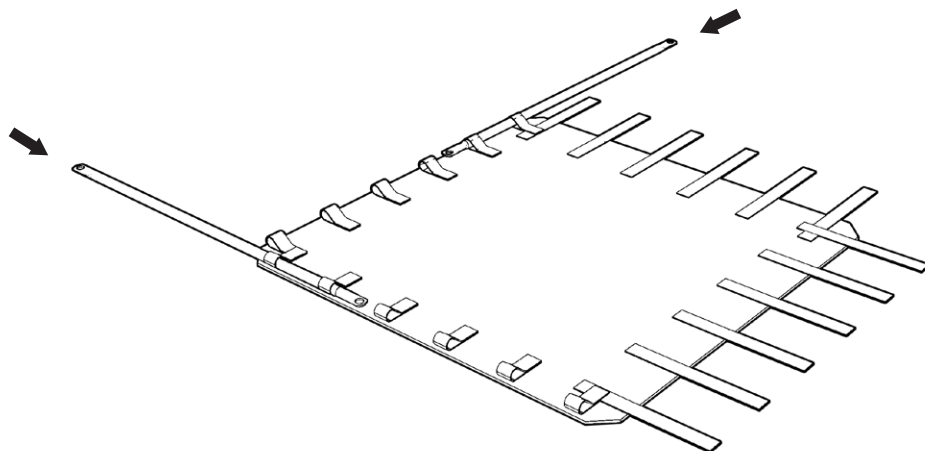
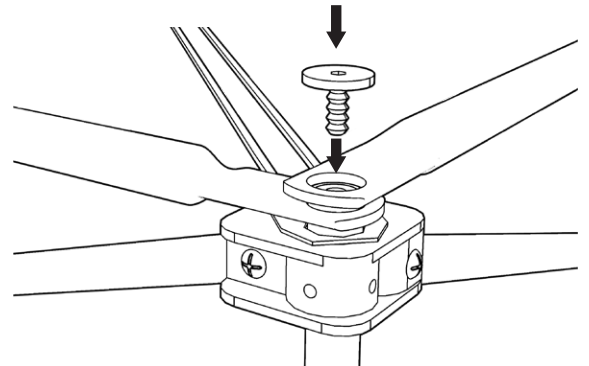

Next, slide the other two cross braces through the two fixed (non-velcro) sides of the seat deck as shown.

Step 3: Place Seat Deck

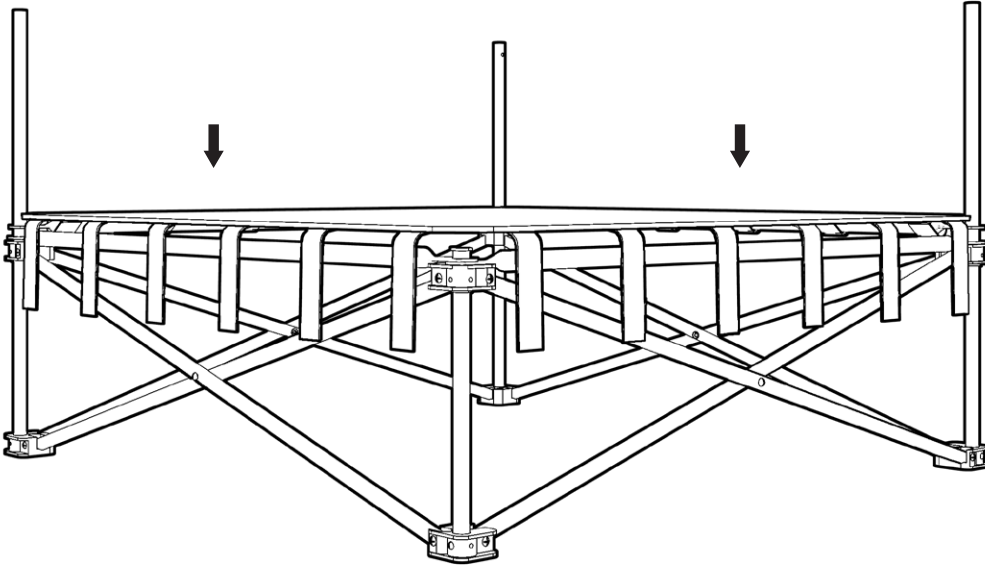

Flip the seat deck over and slide the seat cross braces down the extended uprights.

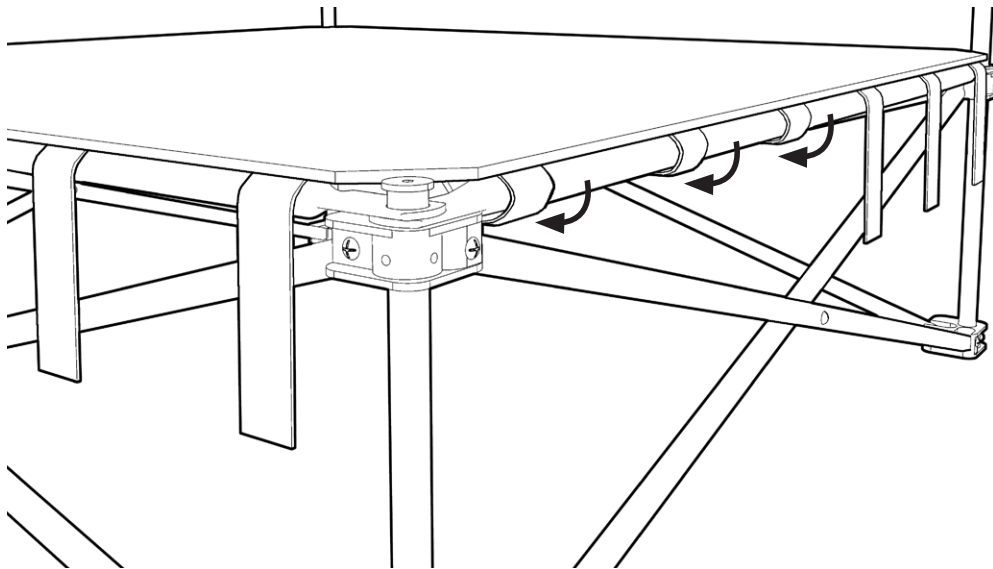

Tightly pull the velcro straps over the cross braces and secure underneath.

Step 4: Arm/Back Crossbar Installation

For the Corner & End units: insert the bar with the attached mounting sleeve. Make sure the sleeve is in the corner.

Next attach the shorter end of the other bar into the mounting sleeve and the longer end into the remaining upright.

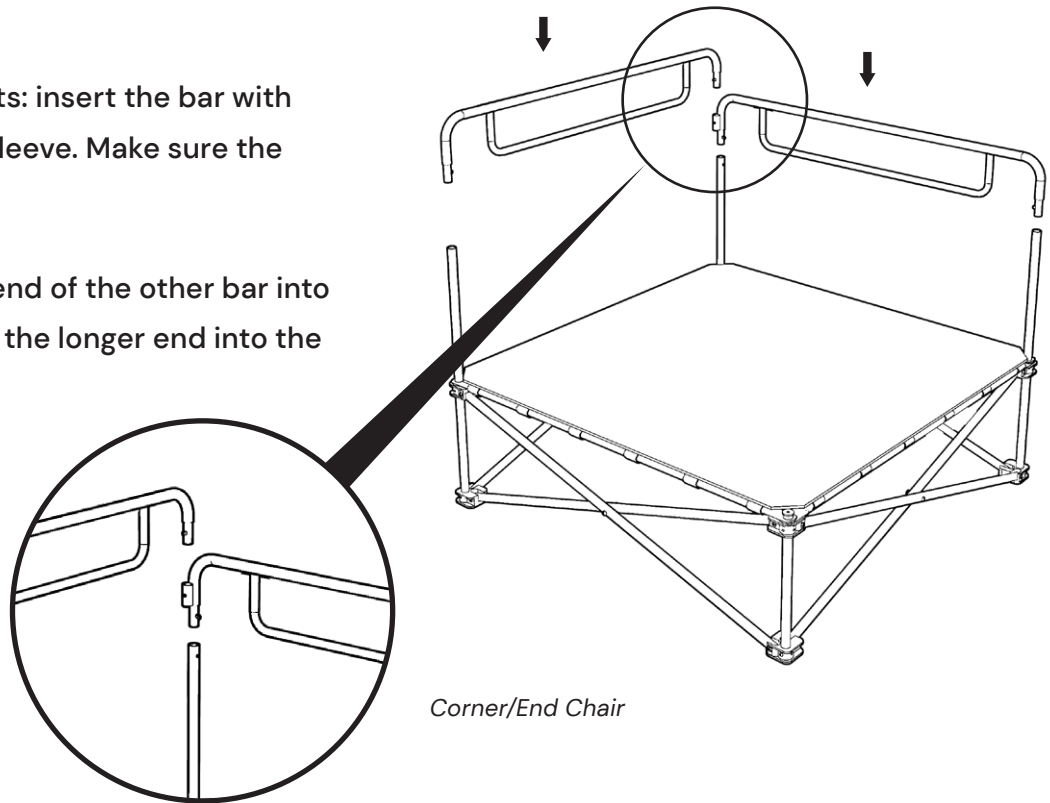

For the Armchair: Insert the bar with the attached mounting sleeves to the back. You will notice that the detent pins are mounted to the frame on the two back uprights.

Then attach the shorter end of the other bars into the mounting sleeve and the longer end into the remaining uprights.

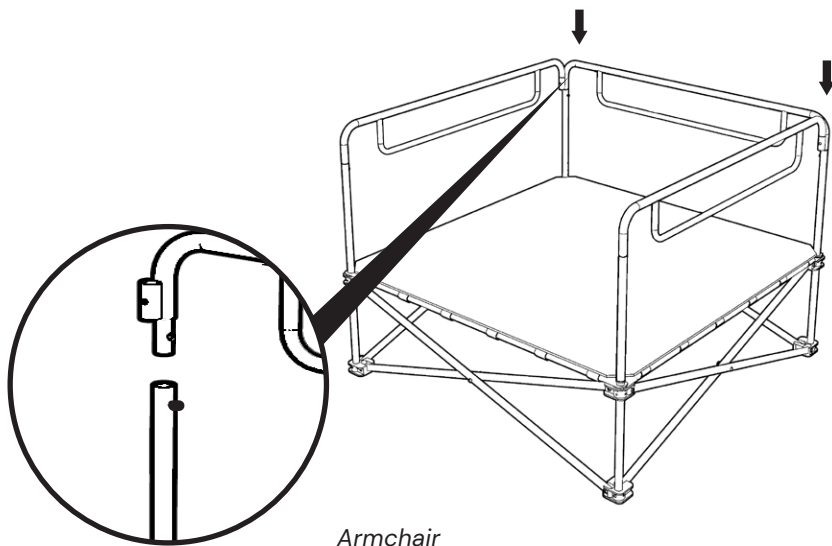

For the Armless unit: Insert back crossbar directly in the two uprights.

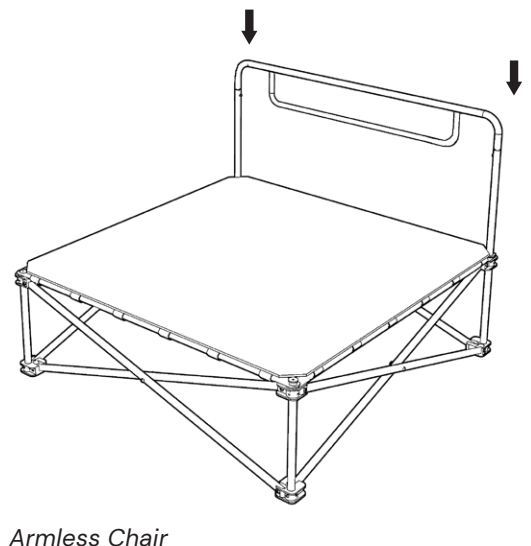

Step 5: Stuffing Pillows and Cushion

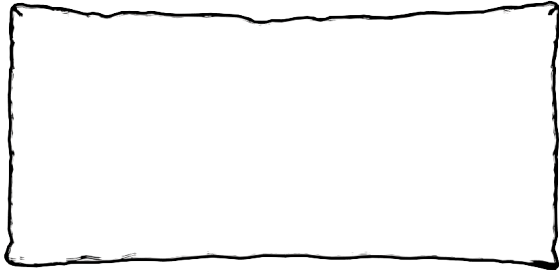

Pillows

Remove pillow insert(s) from vacuum bag. The pillow insert will need to be fluffed up prior to insertion in the cover. The pillow comes overstuffed, you can open the zipper and remove some of the filling to achieve the desired firmness. Any unwanted foam fill can be discarded with your recyclables.

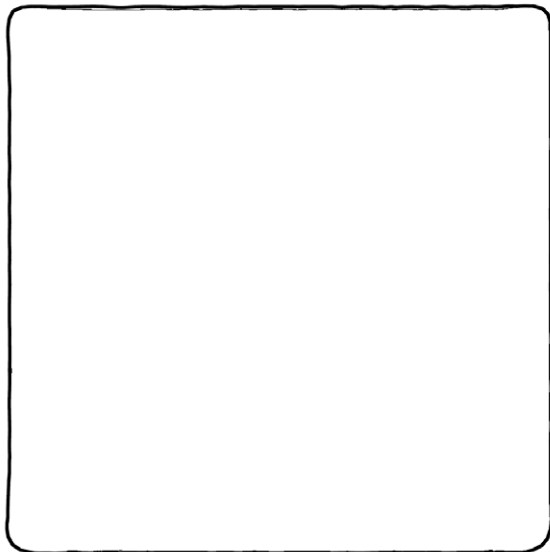

Seat Cushion

Remove the cushion from the vacuum bag. The solid foam side should be inserted facing down. The top of the cushion comes overstuffed, you can open the zipper and remove some of the filling to achieve the desired firmness. Any unwanted foam fill can be discarded with your recyclables.

Step 6: Cover the Chair

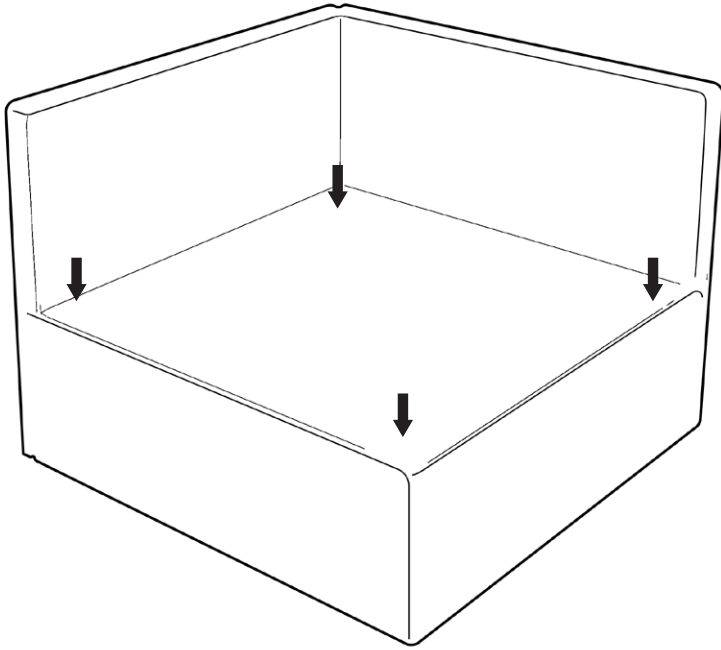

Pull the duvet cover over the frame.

Attach the duvet to the frame by tying the duvet straps to the frame at each corner

Next, pull the slipcover over the duvet and frame.

Place the seat cushion & pillows on the unit and you are done!

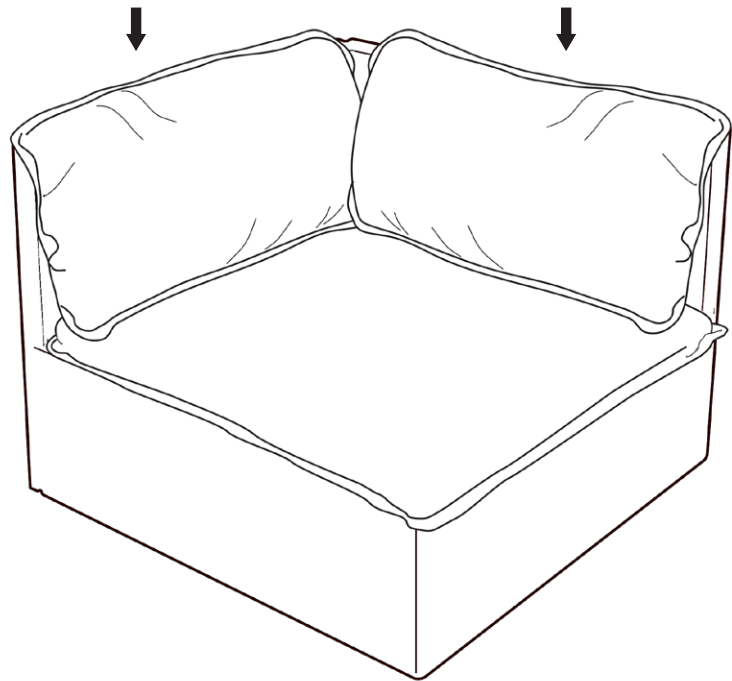

Step 7: Attach Multiple Units

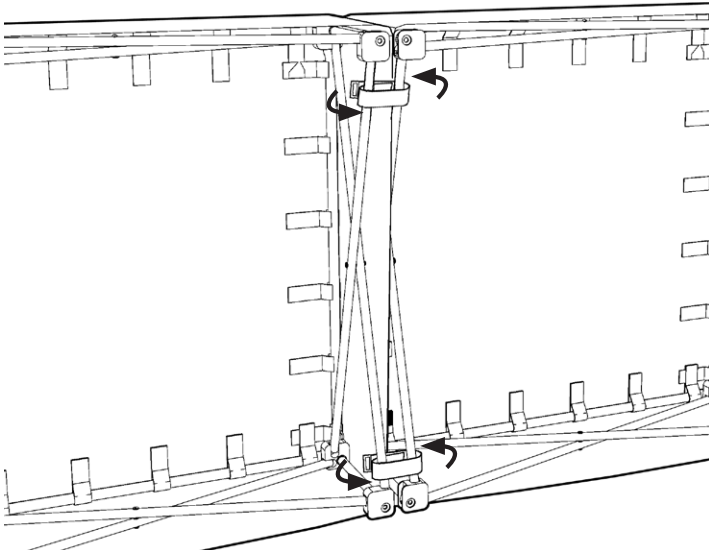

Version 1: Units tilted upwards

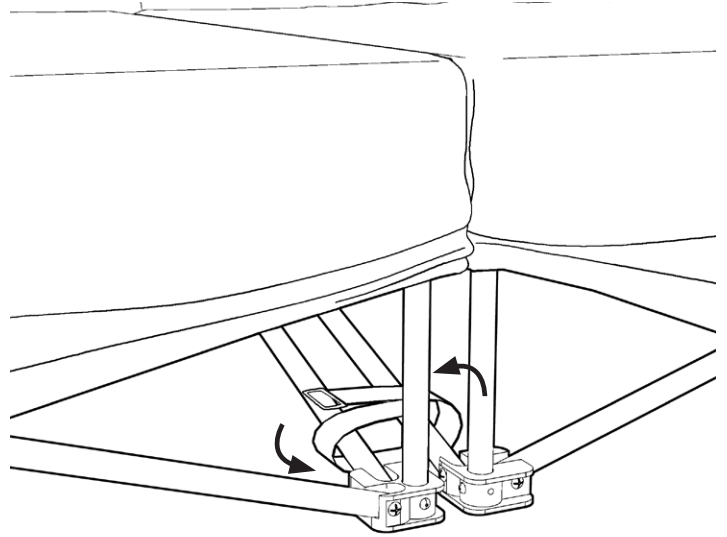

Version 2: Lifting Covers

To connect two or more units together, wrap a frame strap around both frame cross bars at the lowest point in the front and rear of the unit.

This can be done with the units tilted up or from the ground by lifting the covers up to gain access.

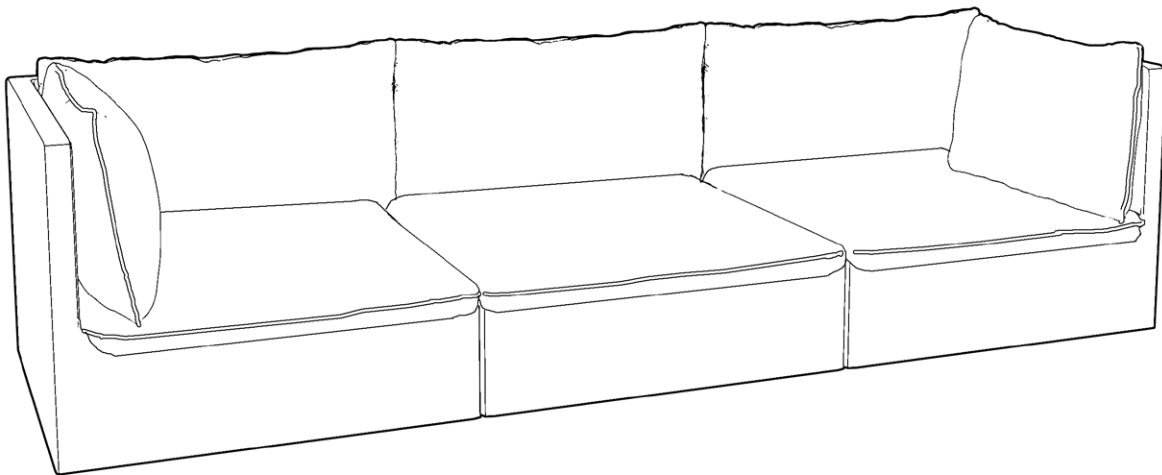

Fabric Care Instructions

Cleaning Codes

All of our fabrics have the following cleaning code:

- SOLVENT OR WATER CLEANABLE (S/W)
Spot clean with upholstery shampoo, foam from a mild detergent, or a mild dry cleaning solvent.

Machine Washable

All of our fabrics are machine washable. It must be Machine Wash – Cold. Use Cold Water and a mild detergent on a low/gentle cycle. Hang dry all covers. Please note that every machine wash adds wear to the fabric so it's recommended to opt for spot cleaning prior to machine washing whenever possible.

Spot Cleaning

We recommend spot cleaning with either an upholstery shampoo, foam from a mild detergent, or a mild cleaning solvent. Always hang to dry. When spills happen, blot immediately to remove the spilled material. Clean spots or stains from the outside to the middle of the affected area (this prevents circling). To prevent overall soiling, frequent vacuuming to remove dust and grime is recommended.