

HD Live Camera



User Manual
(V1.10)

Precautions

This manual describes in detail the functions, general principles and methods of installation and operation of the equipment.

Please read carefully before installation and use.

1. Usage

In order to avoid damage to this product or any product connected to it, this product can only be used within the specified scope

- This machine can not be exposed to rain or damp.
- Installation and maintenance can only be performed by qualified technicians; otherwise, there may be danger of electric shock.
- This product can only be used with limited temperature, humidity or power specifications.
- When cleaning the lens of the equipment, please use the clean cloth in the accessories, and gently wipe with a neutral cleaner when the dirt is serious. Do not use strong or corrosive detergents to avoid scratching the lens and affecting the image effect.

2. Electrical safety

The installation and use of this equipment must strictly abide by the local electrical safety standards.

3. Transport carefully

The damage to the product caused by heavy pressure, violent vibration and immersion should be prevented in the process of transportation, storage and installation.

4. Power polarity

This product is powered by DC 12V power supply.

5. Install carefully

1) If the bracket screw is too long to be tightened when the equipment is installed on the 1amp 4 inch screw, the rubber gasket in the accessory can be used.

2) When using this product, do not tilt the installation of the product; otherwise, the picture may be skewed.

3) The shell of this product contains ABS material and aluminum alloy material, and it is forbidden to come into contact with all kinds of liquid, gas or solid substances that may cause corrosion of the shell.

4) Do not power on until all installation is completed

6. Equipment warranty

This product has no parts that can be repaired by the user, and the damage caused by the user's self-disassembly is not covered by the warranty.

7. Magnetic field interference

The electromagnetic field at a specific frequency may affect the image of the machine; this product is a class A product. Radio interference may be caused in the home environment, and users need to take appropriate measures.

1. Quick installation instructions

1.1. Product interface

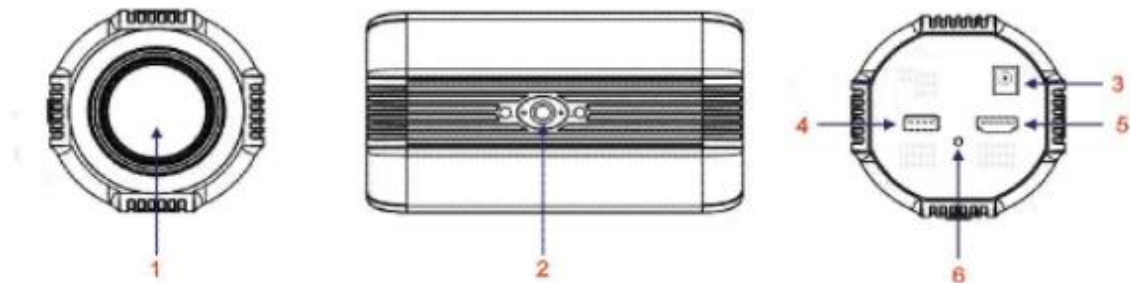

Fig. 1.1 Product interface

Interface Description:

- | | | |
|------------------|--|--------------------------|
| 1. Lens | 2. Tripod fixing hole (1/4 inch screw) | 3. DC12V power interface |
| 4. USB interface | 5. HDMI interface | 6. Indicator light |

1.2. Power-on self-check

Power on: DC12V power adapter is connected to the device power input socket.

Self-test of the whole machine: after power-on, the movement first shrinks and then stretches, the movement returns to the maximum wide-angle position, the equipment is normally identified on the computer, and the USB interface and HDMI have video output, indicating that the self-test is complete.

1.3. Video output

This series of products have a variety of video output methods: USB video output, HDMI video output, network video output.

1) HDMI output

a. The video output of the HDMI of the device is up to 1080p 60 frames.

b. Connect the device and the monitor correctly through the HDMI video cable, and the self-test of the device can be completed.

2) USB output

USB supports up to 1080P30 frames.

Connect the device and the computer correctly through the USB cable, open the video software and select the device named "HD UCamera" image device to draw the picture.

2. Product overview

2.1. Product introduction

2.1.1. Dimensions

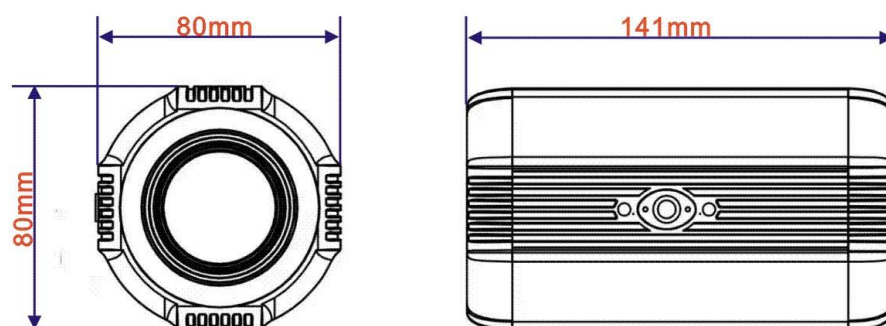

Fig. 2.1 Dimensions

2.1.2. Accessories

When opening the package, please check and confirm all the accessories that should be provided. The random attachment of the product is shown in Table 2.1:

Table 2.1 Accessories included with the product

Accessories	Standard
	Product manual *1
	Wireless remote control *1
	USB cable *1
	Warranty card *1
	DC12V power supply *1
	A dust-free cloth (for cleaning the lens)
	Round rubber gasket * 2

2.2. Product features

This product is a brand new high-definition camera designed for the live broadcast industry. It adopts

the imported focusing algorithm, which enables faster, more accurate and stable focusing; adopts advanced ISP processing technology and algorithms, which enables vivid image effects, uniform picture brightness, strong light and color layers, high definition, and good color reproduction. The product is stable and reliable, easy to operate and use, and easy to install and maintain. Suitable for various live broadcast scenarios.

Features:

- **Full HD image:** adopting a 1.8in 2.07-million-pixel high-quality image sensor with a maximum resolution of 1920 × 1080 and an output frame rate of up to 30 frames per second, presenting a clear and realistic HD video, vividly showing the expressions and actions of the characters.
 - **Optical zoom lens:** adopting 10x 71 °wide-angle lens or 20x optical zoom 62 °wide-angle lens.
- Rich video interface:** support HDMI, USB, network video output.

Leading auto-focusing technology: adopting advanced focusing algorithm to make the lens focus quickly, accurately and stably.

- **Horizontal and vertical screen:** support the built-in menu to switch between horizontal screen and vertical screen output mode, to better meet the needs of customers for horizontal and vertical screen playback.
- **Professional image style:** it can well support the live broadcast of beauty and jewelry style, which is the best image effect for the live scene adjustment.
- **A variety of video compression standards:** the interface supports YUY2, MJPEG, H264, video compression format.
- **Low noise and high signal-to-noise ratio:** low-noise CMOS effectively ensures the ultra-high signal-to-noise ratio of camera video; advanced 2D and 3D noise reduction technologies are used to further reduce noise and ensure image clarity at the same time.
- **Easy to use:** no need to download driver; USB output plug and play, with convenient and simple user experience

Technical Parameters:

Parameters/Model	
Camera and lens parameters	
Image Sensor	1/2.8 sensor
Effective Pixels	2 million, 16:9
Video signal	<p>Video formats supported by HDMI output: 1080I@60fps, 1080I@50fps, 1080P@30fps, 1080P@25fps, 720P@60fps, 720P@50fps;</p> <p>USB output supports video formats: Horizontal screen: 1920×1080@30fps, 1280×720@30fps, 1024×576@30fps, 960×540@30fps, 800×448@30fps, 640×360@30fps, 640×480@30fps, 320×176P30fps; Vertical screen: 1080×1920@30fps, 720×1280@30fps, 576×1024@30fps, 540×960@30fps, 448×800@30fps, 480×720@30fps, 480×640@30fps;</p>

Perspective	3.64°~62°20x lens 8.8°~71°10x lens
focal length	4.7~94mm, 20x lens; f=4.34mm~41.66mm, 10x lens
aperture	F1.5~F3.0 18x lens F1.85 ~ F2.63 10x lens
optical zoom	18X/10X
Minimum illumination	0.1Lux (F1.8, AGC ON)
Digital noise reduction	2D & 3D digital noise reduction
Super automatic noise reduction	Switch
White balance	Auto/Manual/One-button white balance / 3000K/3500K/4000K/4500K/5000K/5500K/6000K/6500K/7000K
Focus	Auto/Manual/One-button white balance;
Exposure	automatic / manual
BLC	switch
Signal-to-noise ratio	>50dB
Portrait switch	switch
Minimum object distance	15cm (wide angle) ~ 150cm (narrow angle)

Interface function performance

Video output interface	1-way USB interface: Type A port, support video signal output; 1-way HDMI interface: support video output
Video compression format	YUV, MJPG, H.264
Control interface	USB interface

Other parameters

Working voltage and current	Voltage	Power Adapter	DC12V
	Current	Power Adapter	0.55
Power consumption	5W(max)		
stored temperature	-10℃ ~+60℃		
Storage humidity	20%~90%		
Operating temperature	-10℃ ~+50℃		
Working humidity	20%~80%		
Dimensions (width X height X depth)	68 mm×138 mm×75mm		
weight	About 0.6kg		
Use environment	indoor		
Appendix	Manual, warranty card, USB cable, power adapter, wireless remote control, dust-free cloth, rubber gasket		

3. Product Usage

3.1. Usage of remote control:

Both the camera and the remote control have four kinds of address codes, which are A, B, C and D. when the remote control and the camera address codes match, the camera can be controlled normally. The default address code for cameras and remote controls is A.

The method of setting the remote control address code: directly press the "A", "B", "C", "D" buttons on the remote control

The method of setting the camera address code: use the remote control to enter "menu" → "system" → "remote control address" → "modify address with left and right buttons" → "confirm".

Note: After the camera address is modified, the address of the remote control must be modified to be the same as that of the camera to control it.

Button Introduction

1. HOME

Press the return button and the camera lens will return to the maximum angle position or return to the previous menu.

2. Equipment selection/code matching (ABCD)

Select the device to be controlled. Code matching refers to pressing a button, and then controlling it after pressing the button in the subsequent control. This remote control can control four devices, divided into A\B\C\D;

3. Number buttons

Call preset positions 0-9;

- "T" and "W" buttons

Press "T" to zoom in, and press "W" to zoom out;

- "F" and "N" buttons

Press "F" and "N" buttons to manually control the focus of the camera

6. Direction control buttons (up, down, left, right)

Control the up, down, left and right rotation of the camera (only effective for PTZ), and control the menu to move up and down, left and right in the menu mode



7. MENU/OK: Enter the menu or enter the next menu;

8. F1~F6 buttons: special function buttons

9. Set and clear preset position buttons (Add, Del)

Set the preset position: After adjusting the camera to the corresponding position, press the set preset (Add + number buttons (0-9) to set the preset position of the corresponding number button;





10. Power button ()

Press the power button to turn off or turn on the camera

3.2. Menu settings

3.2.1. Main menu

Display the contents of the menu on the screen, pointing to the selected item with the scroll arrow.



Press , , move up and down to select the content you want to set, press [ ] to modify, press [menu / confirm] to confirm or enter the submenu, and press [return] to return. Note: after modifying the options, you need to press [menu / confirm] to confirm!

Main Menu

=====

LANG	CH/EN
Scene	Default
Common	
System	
Camera	
Version Information	
Default	
Return	

1. Language: Chinese and English settings of the menu

In the main menu, move the pointer to (LANG/language), press [ ] to modify Chinese or English

2. Scene: Press [ ] to switch scenes such as "default", "beauty", "jewelry" and "clothing"

3. Common: adjust image brightness, color, style and other parameters

4. System: Set the output frame rate and resolution of the camera, and the address code of the remote control to control the camera.

5. Camera: Set the camera's scene, lens, image, exposure, white balance, enhancement, other → image flip, horizontal and vertical screen and other parameters.

6. Version information: display the camera's software version, remote control address and other information.

7. Default: restore the factory settings of the camera.

4. Maintenance and troubleshooting

4.1. Product Maintenance

- 1) If the device is not in long-term use, disconnect the power supply when it is not in use.
- 2) Use soft cloth or cotton paper to remove dust from the equipment shell. Otherwise, it may cause scratches.
- 3) When cleaning the lens of the equipment, please use the clean cloth in the accessories, if the dirt is serious, gently wipe with a neutral cleaner. Do not use strong or corrosive detergents. Otherwise, the lens may be scratched and the image effect may be affected.

4.2. Troubleshooting

1) No picture for video output

Solution:

- a. Check whether the USB cable of the device is well connected and whether the power indicator is on
- b. Check whether the device is in standby state, press the power button on the remote control to see if the image is normal
- c. Check whether the device is normal after power off and restart
- d. Restart the computer to check whether it is normal
- f. Check whether the video output cable is normal
- g. Check whether the device is recognized normally, uninstall the device when it is displayed in the device manager that it cannot be recognized normally, and reload it

2) Image failure

Solution:

- a. Check whether the USB cable is normal
- b. Check whether the USB cable of the device is well connected
- C. Restore the camera to factory settings.

3) Remote control failure

Solution:

- a. Press the "A" button on the remote control, and then try to see if it works
- b. If you have modified the camera address, you can try to set the remote control to A, B, C, and D addresses to see if you can control it.
- c. Check whether the battery of the remote control is installed correctly, or replace the battery and try again.
- d. Check whether the image of the camera is normal and whether the image has been stuck.

5. Copyright statement

The copyright of all the contents of this manual belongs to our company. Without the permission of our company, it is not allowed to imitate, copy, replica or translate arbitrarily. This manual does not have any form of guarantee, position expression or other implication. The product specifications and information mentioned in this manual are for reference only, and the content will be updated at any time without notice.

All rights reserved, no reproduction is allowed.