

IMPORTANT WARNINGS

Rack Installation

Inadequately secured loads and incorrectly mounted roof racks and accessory racks can come loose during travel and cause serious accidents! Therefore, installation, handling and use must be carried out in accordance with product and vehicle instructions.

In addition to these instructions, review the mounting instructions for the roof rack and the operating instructions of the vehicle.

These instructions should be kept together with the vehicle's operating instructions and carried in the vehicle when in use and en route.

For your own safety, you should only use roof racks that are authorized for use with your vehicle.

For roof racks that do not specify the distance between the front and rear crossbars, the distance shall be at least 700 mm or as large as possible. Please note that changes (e.g. additional drill holes) to the accessory rack's attachment system are not permissible.

Check attachment hardware and load for tight fit and function:

- Before the start of any journey.
- After driving a short distance following rack or load install.
- At regular intervals on longer journeys.
- More frequently on rough terrain.
- After interruption of a journey during which the vehicle was left unsupervised (check for damage due to outside intervention).

Rack Loading

Do not exceed the maximum load specified for the roof rack, accessory rack or the maximum load recommended by the vehicle manufacturer.

Max Roof Load = weight of roof rack + weight of accessory racks + weight of load.

Load shall be uniformly distributed with the lowest possible center of gravity.

Load should not substantially extend beyond the loading surface of the roof rack.

Vehicle Driving and Regulations

The speed driven must be suited to the load transported and to official speed limits. In the absence of any speed limits, we recommend a maximum speed of 80 mph (130 km/h).

When transporting any load, the speed of the vehicle must take into account all conditions such as the state of the road, the surface of the road, traffic conditions, wind, etc. Vehicle handling, cornering, braking and sensitivity to side winds will change with the addition of roof top loads.

If this product is off-road certified, it is designed and intended to be used on forest service roads, access roads or other non-technical terrains at moderate speeds. It is not to be used while rock-crawling, jumping, bogging, or other technical off-road terrains. When using off-road certified products with non-off-road certified products, always follow the warnings and restrictions stated in the non-off-road certified product instructions.

Maintenance

The accessory rack should be carefully cleaned and maintained, particularly during the winter months. Use only a solution of water and standard car wash liquid without any alcohol, bleach or ammonium additives.

For reasons of fuel economy and the safety of other road users, the accessory rack and roof rack should be removed when not in use.

Periodically inspect accessory rack for damage. Replace lost, damaged or worn parts. Use only original spare parts obtained from a stocking specialist, dealer or manufacturer.

Any changes made to the roof racks and accessory racks as well as the use of spare parts or accessories other than those supplied by the manufacturer will lead to the lapsing of the manufacturer's warranty and liability for any material damage or accidents. You should observe these instructions to the letter and only use the original parts supplied.

Note 1: Please read Instructions **CAREFULLY** before assembly.

Note 2: Retain this manual for future reference.

Note 3: IF ANY, additional pieces such as Kit/Bracket check further instructions

Note 4: SOME PARTS COME WITH **PRE-INSTALLED, OPEN-LOOSEN-TIGHTEND FOR FINAL ASSEMBLY**

Note 5: If you have any questions or concerns you may contact our customer service department.

info@roofrackrail.com

Text/Whatsapp

+1 470-970-0596



SCAN ME

ROOF RACK Instructions

PRO 6

S E R I E S

Bed Rack



PAW

TOROS

BRACK

Statically:
450kg
 Dynamically:
90kg

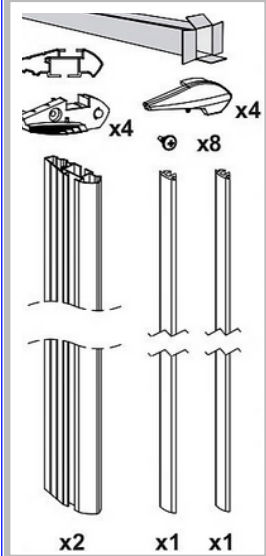
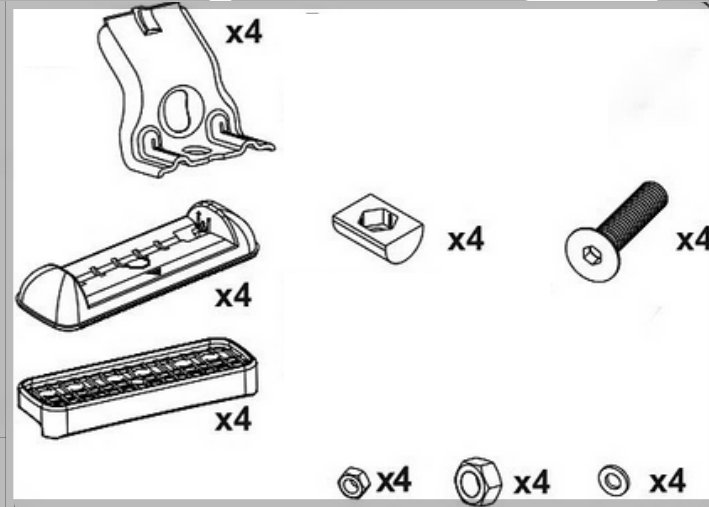
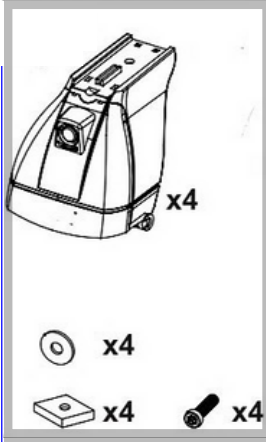
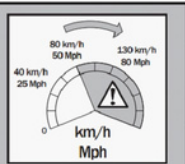
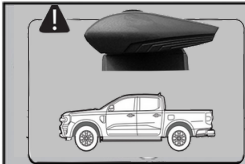
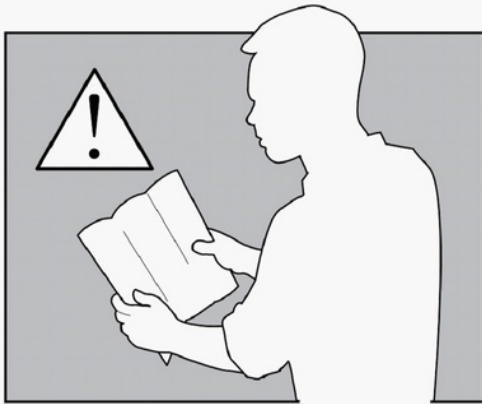

If it is **assembled** skip to **Step 9**

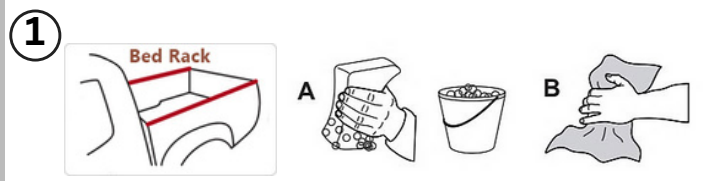

Kindly ensure the areas where the crossbar will be placed are clean

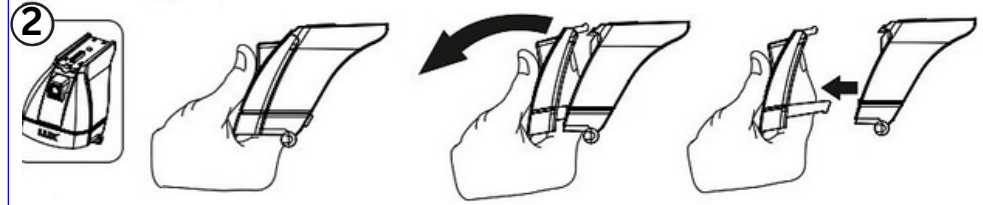

Please gently unfasten the cap in order to proceed with the installation process

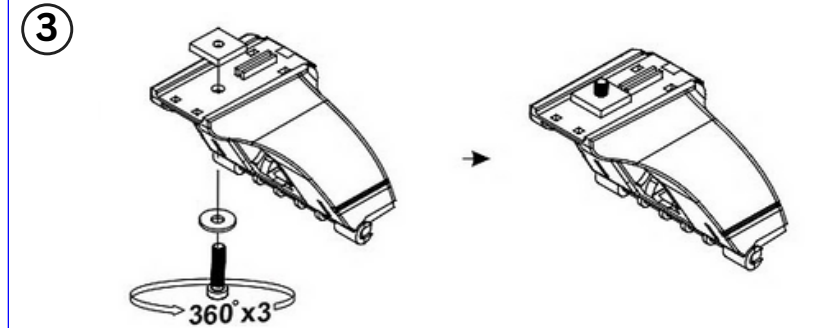

Proceed to fasten the bolts individually on each side, fully tightening them.

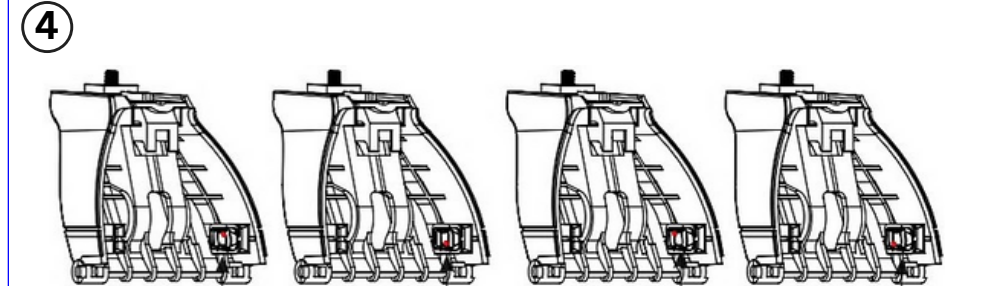

Make sure you have 4 feet for crossbar

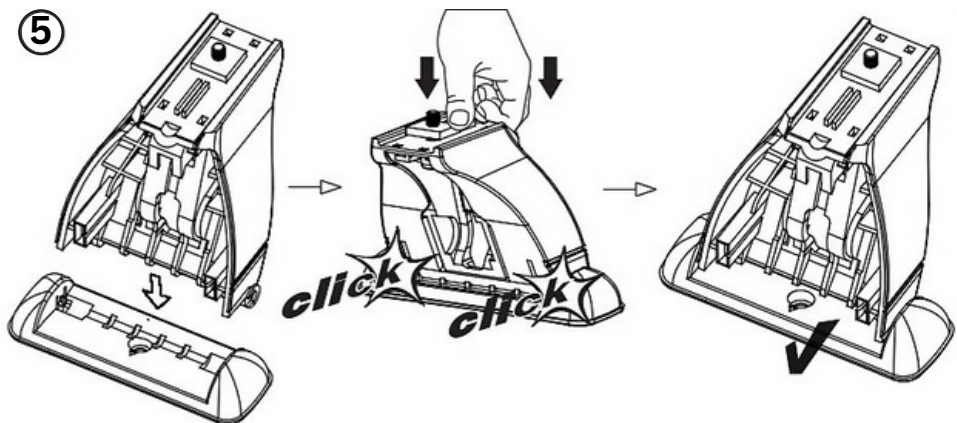

5 Please press or tap the plastic located at the bottom of the foot, just as it is depicted in the image above.

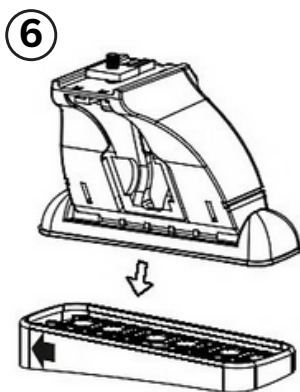

6 Please press or tap the rubber band located at the bottom of the foot, just as it is depicted in the image above.

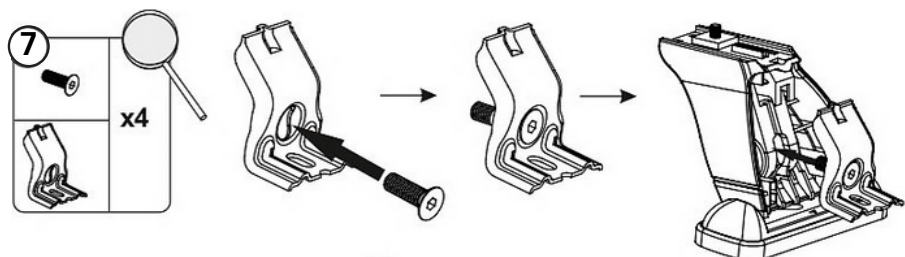

7 Proceed to fasten the bolts individually on each side, **fully** tightening them.

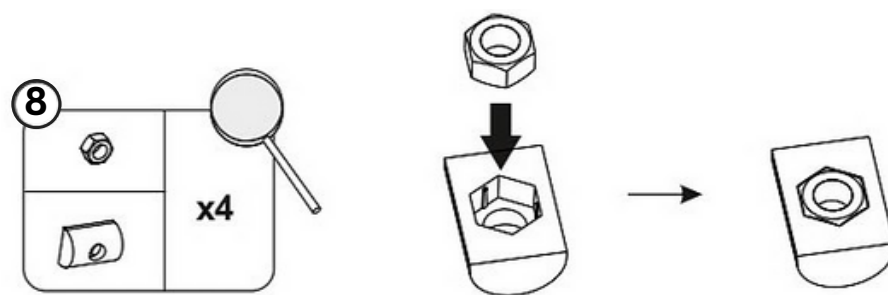

Please arrange the bolts in the same manner as they are displayed in the image above.

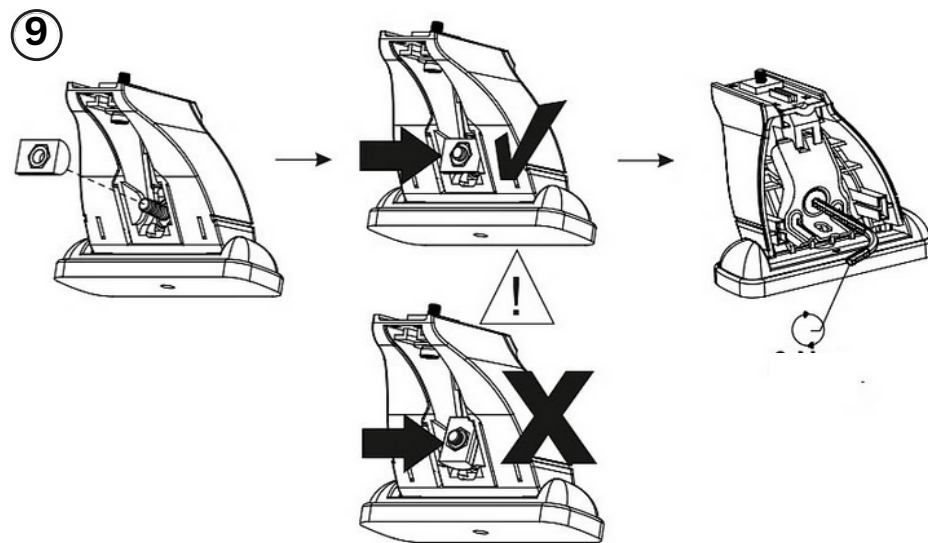

9. I. Make sure the bolt is **straight**, matching the example provided in the image above, and not in any other arrangement.

10

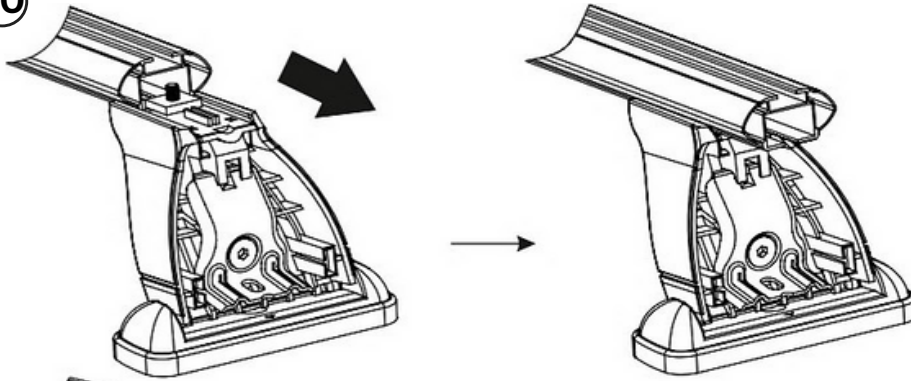

Please proceed to place the aluminum bar onto the foot.

11

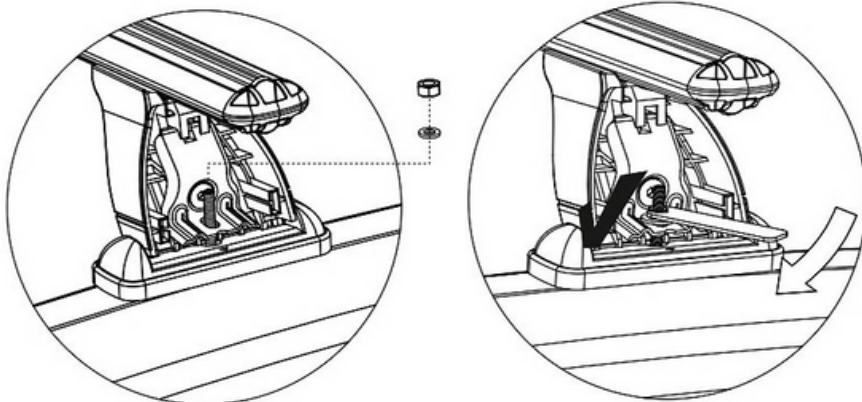

Adjust/put the nut in the canal properly

Proceed to fasten the bolts individually on each side, **fully** tightening them.

Canal ←



12

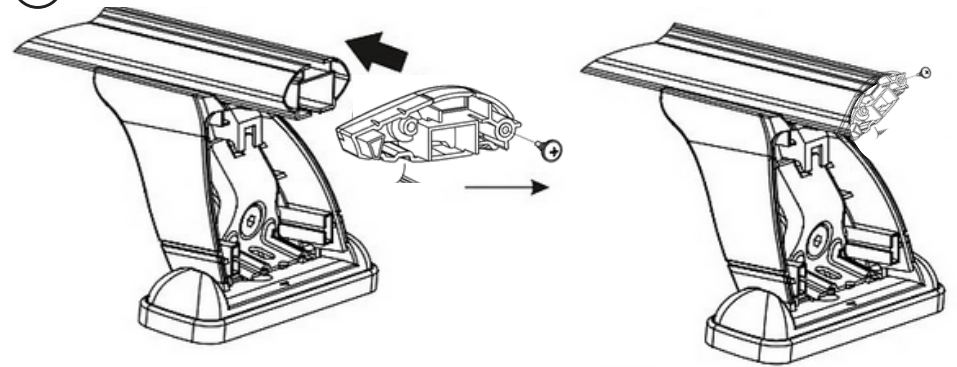

1) Tighten bolts completely to secure.

13

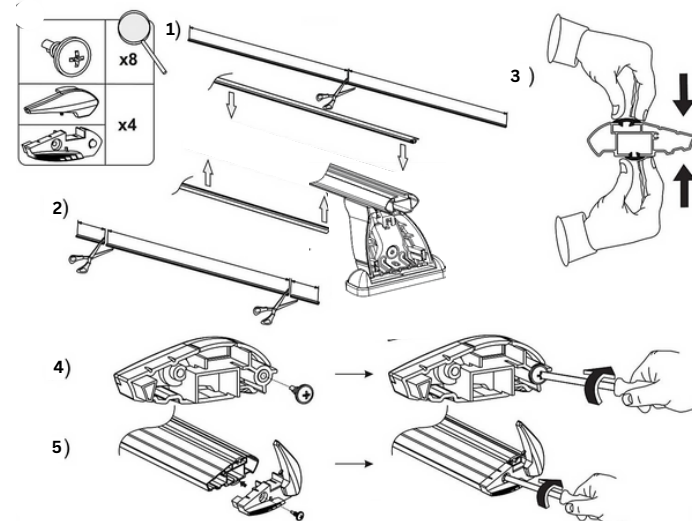

1) Place rubber stripe on **top** of crossbar; trim any excess if necessary.

2) Place rubber stripe on **bottom** of crossbar; trim any excess if necessary.

3) Ensure that there is no space left when trimming the excess rubber strip.

4) Tighten completely to secure.

5) Tighten completely to secure.

14

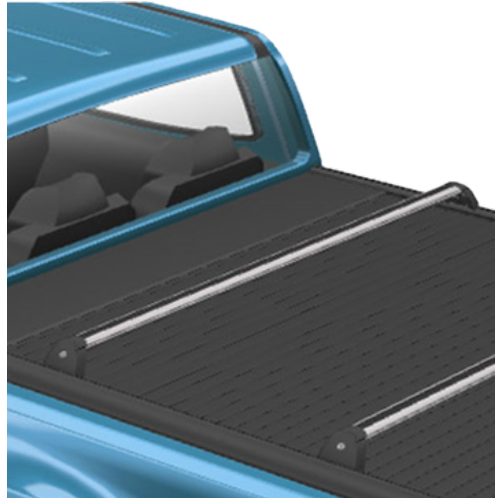
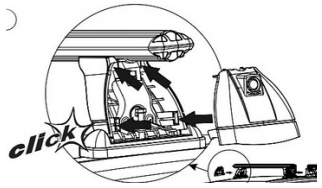

I. Attach a cap to each end of the crossbar.

15



Please verify that the crossbar is both steady and firmly in place.

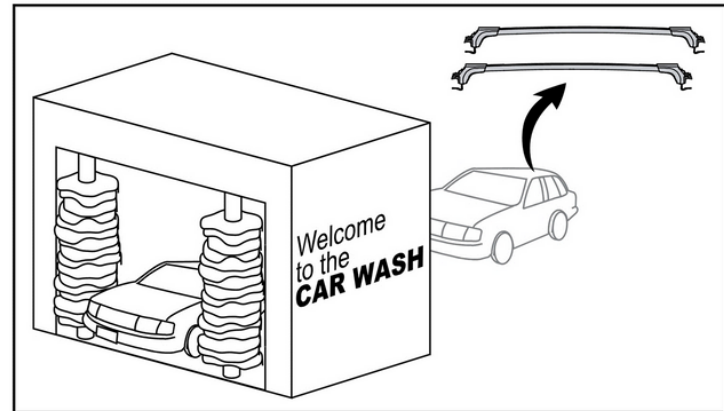
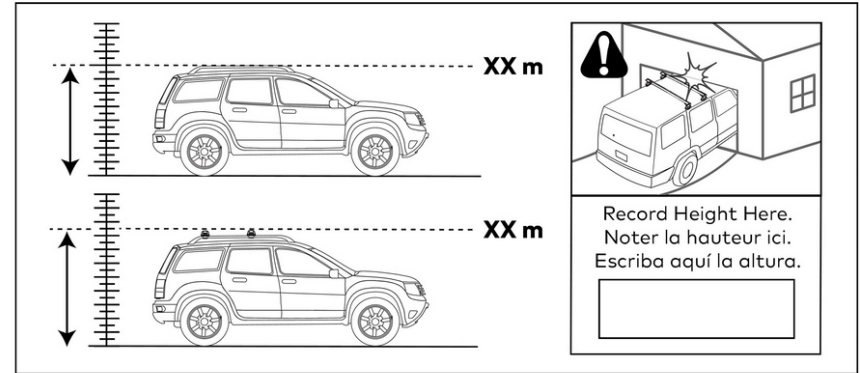



WARNINGS

EN

FITTING

01. Check with the assembly instructions that all the necessary parts are present.
02. Clean the car roof and those parts of the product that come into contact with the roof before and regularly during use.
03. Go through and carefully follow the assembly instructions and the recommendation list, if one is included. Then fit the unit in the correct sequence, that is to say 1, 2, 3 and so on.
04. If no special fitting positions are given in the assembly instructions, try to maintain a minimum distance of 700 mm between the load carrier bars.
05. When carrying long loads, the distance between the load carrier bars should not be less than 700 mm.
06. Every time the unit is fitted, check that the load carrier is sitting securely on the roof. Try to push and pull the carrier out of its locked position. Try also to pull out the tensioning tabs from the roof edge. If you manage to move any part of the unit, the load carrier must be secured more firmly. This test should be carried out regularly.
07. Some types of sunroof and radio antenna cannot be used when the carrier is fitted.
08. The roof rack is permitted to be assembled on cars with glass roof, unless otherwise is specified in mounting instruction.
09. The manufacturer can not be held responsible for personal damages of property or loss of fortune caused by incorrect mounting or use of the product.
10. No modifications to the product are permitted.
11. Consult with your dealer if you have any questions regarding the operations and limits of the products. Review all instructions and warranty information carefully.

LOADING

01. The maximum load specified in the assembly instructions is not to be exceeded. However, this limit is always subordinate to the maximum load recommended by the manufacturer of the car itself. It is always the lower maximum recommended load that applies. **Max. roof load = load carrier weight + any fitted carrier accessories + the weight of the load itself.**
 02. The load may not significantly exceed the load carrier's width, and it should always be spread evenly across the load carrier and with the lowest possible centre of gravity.
 03. Maximum load applies to driving as well as parked vehicle.
 04. When several surfboards are being carried, they should not be placed beside each other but instead one on top of the other.
 05. When carrying surfboards and other long items, these shall be secured both at the front and the rear of the vehicle.
 06. Skis must be carried with their pointed ends facing the rear of the vehicle.
 07. All loose or removable parts of the load such as bike child seats, tyre pumps, fins and so on should be taken off prior to loading.
 08. The load should be thoroughly secured. Elastic bungees are not to be used.
 09. The load's security should be checked after a short distance, and there after at suitable intervals. Tighten the load's securing straps whenever necessary.
- NOTE! Always check the load's attachment security.

DRIVING PROPERTIES AND REGULATIONS

01. Road speed should always be adjusted to suit the load being carried and the current driving conditions, such as road type and quality, wind conditions, traffic intensity and applicable speed limits.
02. The vehicle's speed must always be adjusted to the load being carried and the current driving conditions, such as the road type, road quality, wind conditions, traffic intensity and applicable speed limits, but must under no circumstances exceed 130 km/h. Applicable speed limits and other traffic regulations must always be observed.
03. Drive slowly over speed bumps, maximum speed 10 km/h.
04. Note that the vehicle's total height increases when upright loads are carried.
05. The vehicle's driving characteristics and braking behaviour change and its vulnerability to side-winds increases when a load is carried on the roof.
06. Products fitted with a lock should always be locked during transport.
07. Off-road driving is only approved for roof rack without load or accessories attached.
08. Adapt your speed to the conditions of the road and load being carried, check tension of load carrier frequently, especially when travelling on rough roads.

MAINTENANCE

01. Check and replace worn-out or defective parts.
02. The load carrier should always be cleaned and maintained, especially in the winter.
03. Screws, nuts and locks (if fitted) should be lubricated at regular intervals.
04. When not in use, the product should be removed from the vehicle.
05. When the product is removed from the vehicle, all loose parts should be stored safely.

WARNUNGEN

DE

MONTAGE

01. Überprüfen Sie in der Montageanleitung, ob alle Teile enthalten sind.
02. Reinigen Sie vor der Montage das Dach des Fahrzeugs und die Bestandteile des Dachträgers, die mit dem Dach in Kontakt kommen.
03. Überprüfen und befolgen Sie sorgfältig Montageanweisungen und die Liste der Empfehlungen, falls vorhanden. Montieren Sie die Teile gemäß der Nummerierung, d.h. Schritt 1, 2, 3 usw.
04. Falls im Handbuch keine spezifischen Montagepositionen angegeben sind, versuchen Sie, zwischen den Trägern einen Mindestabstand von 700 mm zu halten.
05. Bei der Beförderung langer Ladungen darf der Abstand zwischen den Trägern nicht weniger als 600 mm sein.
06. Stellen Sie beim jeden Versuch der Dachträgermontage sicher, dass der Dachträger richtig auf dem Dach des Autos befestigt ist. Versuchen Sie, den Dachträger zu drücken und zu ziehen, um ihn von der gesperrten Position zu bewegen. Versuchen Sie auch, die Montageteile vom Dachrand zu entfernen. Falls Sie imstande waren, einen dieser Teile zu bewegen, bedeutet dies, dass er nicht richtig montiert wurde. Solch ein Test sollte regelmäßig durchgeführt werden.
07. Einige Arten von Schiebedächern und Funkantennen können nicht verwendet werden, wenn der Dachträger montiert ist.
08. Der Dachträger kann auf Autos mit Glasdach montiert werden, es sei denn, die Montageanleitung schließt es aus.
09. Der Hersteller ist nicht verantwortlich für Personen- oder Sachschäden, die durch nicht richtige Montage oder Verwendung des Produkts verursacht wurden.
10. Modifizierung des Produkts ist nicht zulässig.
11. Wenden Sie sich an den Verkäufer, wenn Sie Fragen zum Betrieb und Einschränkungen der Produkte haben. Bitte lesen Sie die Anweisung und Garantiebedingungen sorgfältig durch.

BELADUNG

01. Überschreiten Sie nicht die in der Montageanleitung angegebene maximale Belastbarkeit der Träger. Darüber hinaus beachten Sie bitte die durch den Fahrzeughersteller angegebene, maximale zulässige Belastung des Fahrzeugdaches. Als Limit wird immer der kleinere dieser Werte verwendet. **Maximale Dachbelastung = Dachträgergewicht + Gewicht des montierten Zubehörs + Gewicht der Ladung.**
 02. Die Ladung darf die Breite des Gepäckraums nicht wesentlich überschreiten und muss immer auf dem Dachträger gleichmäßig und mit einem möglichst niedrigen Schwerpunkt verteilt werden.
 03. Die maximale Ladekapazität gilt sowohl für das fahrende als auch für das geparkte Auto.
 04. Beim Transport mehrerer Surfbretter legen Sie sie nicht nebeneinander, sondern übereinander.
 05. Beim Transport von Surfbrettern und anderen langen Ladungen müssen sie sowohl auf der vorderen als auch auf der hinteren Seite des Fahrzeugs befestigt sein.
 06. Die Skier müssen so transportiert werden, dass die spitze Seite nach hinten gerichtet ist.
 07. Alle losen oder abnehmbaren Elemente, wie Fahrrad-Kindersitze, Reifenpumpen, Flossen usw. sollen vor dem Beladen entfernt werden.
 08. Die Ladung sollte sorgfältig gesichert werden. Verwenden Sie keine flexiblen Seile.
 09. Die Ladungssicherung soll nach kurzer Strecke und anschließend in regelmäßigen Abständen überprüft werden. Bei Bedarf müssen die Befestigungsgurte angespannt werden.
- ACHTUNG! Überprüfen Sie immer, ob die Ladung sicher befestigt ist.

FAHREIGENSCHAFTEN UND VORSCHRIFTEN

01. Die Geschwindigkeit des Fahrzeugs muss immer an die zu transportierende Ladung sowie Fahrbedingungen wie Zustand des Straßenbelags, Windgeschwindigkeit, Verkehr und geltende Geschwindigkeitsbegrenzungen angepasst werden, jedoch in keinem Fall 130 km/h überschreiten.
02. Die geltenden Geschwindigkeitsbegrenzungen und Verkehrsregeln sind stets zu beachten.
03. Überschreiten Sie bei Bremsschwellen nicht 10 km/h.
04. Beachten Sie, dass die Höhe des Autos durch die getragene Last erhöht ist.
05. Während der Lastbeförderung erhöht sich die Anfälligkeit für den Seitenwind. Fahreigenschaften des Fahrzeugs sowie Bremsverhalten ändern sich.
06. Produkte, die mit einem Reisverschluss ausgestattet sind, sollten während des Transports immer geschlossen sein.
07. Offroad ist nur erlaubt, wenn keine Ladung und Zubehör auf dem Dachträger installiert ist.
08. Passen Sie die Fahrgeschwindigkeit an Straßenverhältnisse und die zu transportierende Ladung an. Überprüfen Sie regelmäßig die Spannung der Befestigungsgurte, insbesondere wenn Sie auf unebenen Straßen fahren.

WARTUNG

01. Prüfen und ersetzen Sie abgenutzte oder defekte Teile.
02. Der Dachträger sollte immer gereinigt und gewartet werden, besonders im Winter.
03. Schrauben, Muttern und Schlösser (falls vorhanden) sollten regelmäßig geschmiert werden.
04. Wenn der Dachträger nicht verwendet wird, entfernen Sie ihn von dem Auto.
05. Nach dem Entfernen des Dachträgers vom Dach sollten alle losen Elemente sicher gelagert werden.