



Kata-Gi Pedicure Sink

Model # ANS KATAGI-P

Dimensions: 24" L x 21" W x 13 1/4" H

Weight: N/A

Material: Fiberglass / Acrylic

Sink Type: Air Jetted / Whirlpool

Install Application: Surface Mount

Warranty: 1 Year

All measurements are approx.

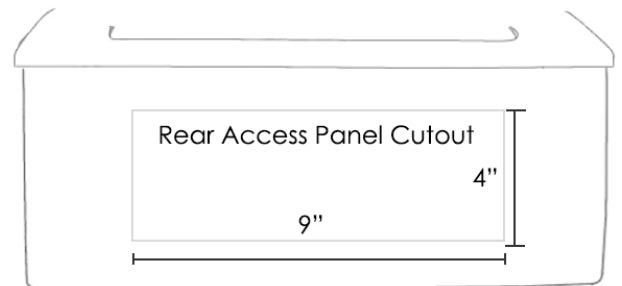
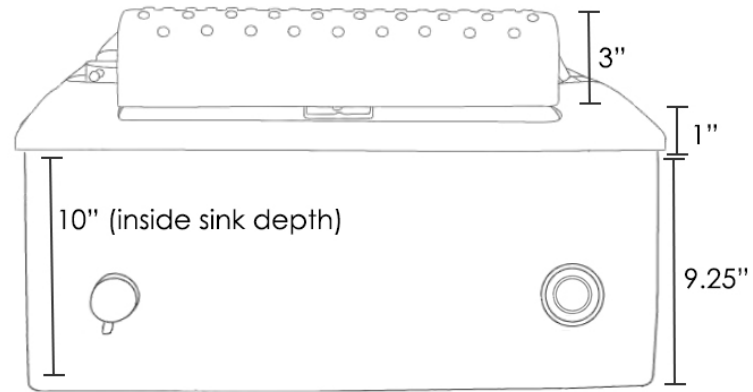
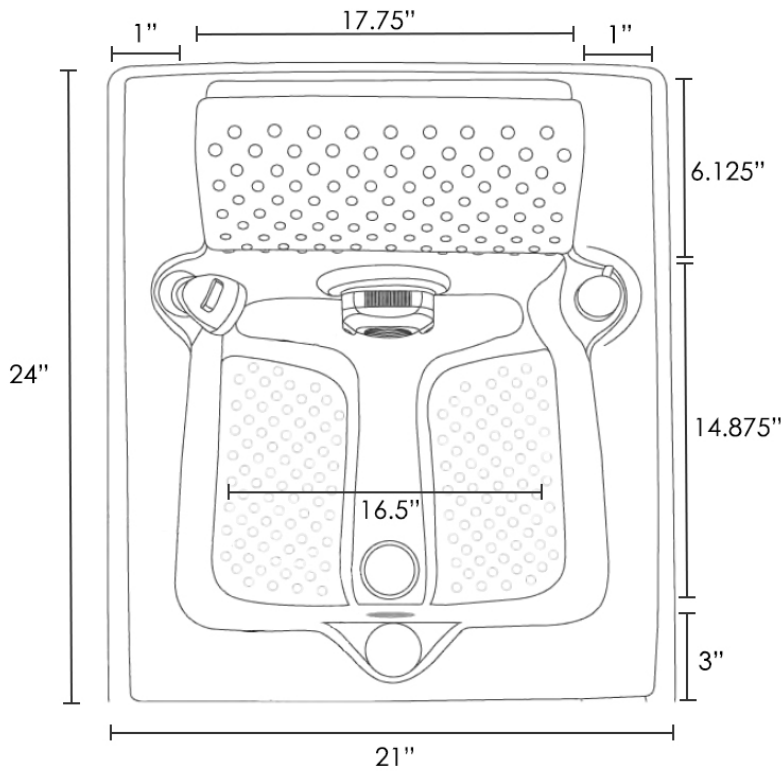
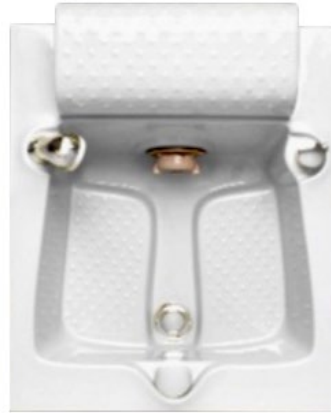

tel: 866.730.7727
email: info@meridianspas.com
web: meridianspas.com / spabowls.com

MERIDIAN SPAS

MANICURE * PEDICURE * BEAUTY

Kata-Gi Pedicure Sink

Sink Specifications

- Overall Dimensions: 24" L x 21" W x 13 1/4" H
- Inside Depth: 10" / Sink Deck Height: 1" / Footrest Height: 3"
- Water Capacity: 4.5 US Gallons (approx.)
- AirJet: 120V / 0.65 AMP / 60 Hz (UL Approved)
- Air actuated power supply with switch (ETL Listed), Dedicated GFCI Required
- Colors: White & Jade

Sink Features

- Fiberglass With Protective Gel Coating
- Smooth polished high gloss finish
- Complete with jet, led light, waste & overflow, faucet/valve, pullout sprayer, power supply and controls
- Fits up to a men's size 13 foot
- 1 Year Warranty against any manufacturer defects (does not cover stain / discoloration by use of harsh chemicals)

Hardware & Components

- Chrome Cable Driven Drain With Overflow (cUPC approved)
- Tilt Adjustable Footrest: 3.5" H / 45 degree tilt
- Pullout Faucet with Backflow Preventer (ASME / CSA approved)
- Chrome Hot & Cold Valve: 1/2" NPSM Connections
- Chrome On/Off Push Button(s)
- For detailed accessory specifications please refer to individual product page/specs



PULLOUT FAUCET



HOT/COLD MIXER VALVE



AIR JET



POWER SUPPLY



WASTE & OVERFLOW



ON/OFF PUSH BUTTON



AIR HOSE



HOT & COLD WATER SUPPLIES

Note

Specifications and details are subject to revisions without notice. For most current specs contact our office