

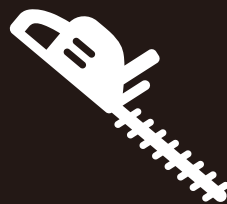

# User Manual

CORDLESS HEDGE TRIMMER  
BBT-YOD01



Please scan the QR CODE for more services.

+1 833 635 0955 [support@snapfreshtools.com](mailto:support@snapfreshtools.com)

**⚠** Read all safety rules and instructions carefully before operating this tool.





# CONTENTS

Contents .....	2
Symbols .....	3
Safety instructions .....	4-8
Machine information .....	8-9
Assembly .....	10-13
Operation .....	14
Maintenance .....	15
Environment .....	15
Warranty .....	16

# SYMBOLS

The following symbols are used in the user manual or on the product:

	<p>Read the user manual.</p>		<p>Class II machine - Double insulation - You don't need any grounding plug.</p>
	<p>Denotes risk of personal injury, loss of life or damage to the tool in case of non-observance of the instructions in this manual.</p>		<p>Time interval microfuse.</p>
	<p>Risk of flying objects. Keep bystanders away from the work area.</p>		<p>Max temperature 45 °C.</p>
	<p>Do not expose to rain.</p>		<p>Do not throw the battery into fire.</p>
	<p>Wear goggles. Wear hearing protection.</p>		<p>Do not throw the battery into water.</p>
	<p>Wear safety gloves.</p>		<p>Separate collection for Li-ion battery.</p>
	<p>Before cleaning and maintenance, always switch off the machine and remove the battery pack from the machine.</p>		<p>Do not dispose of improper products.</p>
	<p>Indoor use only.</p>		<p>The product is in accordance with the applicable safety standards in the European directives.</p>

## SAFETY INSTRUCTIONS

Read the enclosed safety warnings, the additional safety warnings and the instructions. Failure to follow the safety warnings and the instructions may result in electric shock, fire and/or serious injury. Save the safety warnings and the instructions for future reference.

### GENERAL POWER TOOL SAFETY WARNINGS



**WARNING!** Read all safety warnings and all instructions. Failure to follow the warning and instructions may result in electric shock, fire and/or serious injury.

Save all warnings and instructions for future reference.

The term “power tool” in the warnings refers to your mains-operated (corded) power tool or battery-operated (cordless) power tool.

#### 1) Work area safety

- Keep the work area clean and well lit. Cluttered or dark areas invite accidents.
- Do not operate power tools in explosive atmospheres, such as in the presence of flammable liquids, gases or dust. Power tools create sparks which may ignite the dust or fumes.
- Keep children and bystanders away while operating a power tool. Distractions can cause you to lose control.

#### 2) Electrical safety

- Power tool plugs must match the outlet. Never modify the plug in any way. Do not use any adapter plugs with earthed (grounded) power tools. Unmodified plugs and matching outlets will reduce risk of electric shock.
- Avoid body contact with earthed or grounded surfaces, such as pipes, radiators, ranges and refrigerators. There is an increased risk of electric shock if your body is earthed or grounded.
- Do not expose power tools to rain or wet conditions. Water entering a power tool will increase the risk of electric shock.
- Do not abuse the cord. Never use the cord for carrying, pulling or unplugging the power tool. Keep cord away from heat, oil, sharp edges or moving parts. Damaged or entangled cords increase the risk of electric shock.
- When operating a power tool outdoors, use an extension cord suitable for outdoor use. Use of a cord suitable for outdoor use reduces the risk of electric shock.
- If operating a power tool in a damp location is unavoidable, use a Residual Current Device (RCD) protected supply. Use a RCD to reduce the risk of electric shock.

### 3) Personal safety

- Stay alert, watch what you are doing and use common sense when operating a power tool. Do not use a power tool while you are tired or under the influence of drugs, alcohol or medication. A moment of inattention while operating power tools may result in serious personal injury.
- Use personal protective equipment. Always wear eye protection. Protective equipment such as dust mask, non-skid safety shoes, hard hat, or hearing protection used for appropriate conditions will reduce personal injuries.
- Prevent unintentional starting. Ensure the switch is in the off-position before connecting to power source and/or battery pack, picking up or carrying the tool. Carrying power tools with your finger on the switch or energising power tools that have the switch on invites accidents.
- Remove any adjusting key or wrench before turning the power tool on. A wrench or a key left attached to a rotating part of the power tool may result in personal injury.
- Do not overreach. Keep proper footing and balance at all times. This enables better control of the power tool in unexpected situations.
- Dress properly. Do not wear loose clothing or jewellery. Keep your hair, clothing and gloves away from moving parts. Loose clothes, jewellery or long hair can be caught in moving parts.
- If devices are provided for the connection of dust extraction and collection facilities, ensure these are connected and properly used. Use of dust collection can reduce dust related hazards.
- Do not let familiarity gained from frequent use of tools allow you to become complacent and ignore tool safety principles. A careless action can cause severe injury within a fraction of a second.

### 4) Power tool use and care

- Do not force the power tool. Use the correct power tool for your application. The correct power tool will do the job better and safer at the rate for which it was designed.
- Do not use the power tool if the switch does not turn it on and off. Any power tool that cannot be controlled with the switch is dangerous and must be repaired.
- Disconnect the plug from the power source and/or the battery pack from the power tool before making any adjustments, changing accessories, or storing power tools. Such preventive safety measures reduce the risk of starting the power tool accidentally.
- Store idle power tools out of the reach of children and do not allow persons unfamiliar with the power tool or these instructions to operate the power tool. Power tools are dangerous in the hands of untrained users.
- Maintain power tools. Check for misalignment or binding of moving parts, breakage of parts and any other condition that may affect the power tool's operation. If damaged, have the power tool repaired before use. Many accidents are caused by poorly maintained power tools.
- Keep cutting tools sharp and clean. Properly maintained cutting tools with sharp cutting edges are less likely to bind and are easier to control.
- Use the power tool, accessories and tool bits etc. in accordance with these instructions, taking into account the working conditions and the work to be performed. Use of the power tool for operations different from those intended could result in a hazardous situation.
- Keep handles and grasping surfaces dry, clean and free from oil and grease. Slippery handles and grasping surfaces do not allow for safe handling and control of the tool in unexpected situations.

## 5) Battery tool use and care

- Recharge only with the charger specified by the manufacturer. A charger that is suitable for one type of battery pack may create a risk of fire when used with another battery pack.
- Use power tools only with specifically designated battery packs. Use of any other battery packs may create a risk of injury and fire.
- When the battery pack is not in use, keep it away from other metal objects, like paper clips, coins, keys, nails, screws or other small metal objects that can make a connection from one terminal to another. Shorting the battery terminals together may cause burns or a fire.
- Under abusive conditions, liquid may be ejected from the battery; avoid contact. If contact accidentally occurs, flush with water. If liquid contacts eyes, additionally seek medical help. Liquid ejected from the battery may cause irritation or burns.
- Do not use a battery pack or tool that is damaged or modified. Damaged or modified batteries may exhibit unpredictable behaviour resulting in fire, explosion or risk of injury.
- Do not expose a battery pack or tool to fire or excessive temperature. Exposure to fire or temperature above 130 °C may cause explosion. NOTE The temperature "130 °C" can be replaced by the temperature "265 °F".
- Follow all charging instructions and do not charge the battery pack or tool outside the temperature range specified in the instructions. Charging improperly or at temperatures outside the specified range may damage the battery and increase the risk of fire.

## 6) Service

- Have your power tool serviced by a qualified repair person using only identical replacement parts. This will ensure that the safety of the power tool is maintained.
- Never service damaged battery packs. Service of battery packs should only be performed by the manufacturer or authorized service providers.

## ADDITIONAL SAFETY WARNINGS FOR HEDGE TRIMMER

- Keep the area you are working in clean and tidy.
- Always hold the trimmer properly. When operating, use both hands.
- If you are using a means of support to raise yourself off the ground, ensure that it is stable and cannot topple over - do not overreach at any time.
- Do not use power tools in the rain or wet environments. Do not use power tools where there is a risk of fire or explosion - i.e. near flammable liquids or gases.
- Do not allow children into the area where you are working.
- Do not let children or other people touch power tools.
- Do not leave the power tool unattended.
- Store in a dry place well out of children.

- Always use safety glasses and gloves. We also recommend the use of ear protectors.
- Wear the right clothes - not loose fitting or jewellery and ensure garments cannot come into contact with moving parts.
- If you have long hair, tie it back safely to avoid tangling it in moving parts.
- Before using any power tool, check first for damaged parts and if found do not use it before the part or parts have been replaced with new ones.
- Do not use power tools when you are tired or have been drinking alcohol.
- Do not force the appliance - let it work at the rate for which it was intended.
- Do not overreach while working - you may lose your balance.
- Never use this appliance without the blade guard fitted. It must always remain fitted.
- Only use spare parts and attachments supplied by SnapFresh. Use of attachments other than those supplied or recommended by SnapFresh will invalidate your guarantee and could be dangerous.
- Only use this appliance for its intended purpose trimming hedges and bushes.



Above all be careful!



Danger!

- Keep all parts of the body away from the cutting blade. Do not remove cut material or hold material to be cut when blades are moving. Make sure the switch is off when clearing jammed material. A moment of inattention while operating the hedge trimmer may result in serious personal injury.
- Carry the hedge trimmer by the handle with the cutting blade stopped. When transporting or storing the hedge trimmer always fit the transport protection sleeve. Proper handling of the hedge trimmer will reduce possible injury from the cutting blades.
- The cutting elements continue to move after the motor is switch off.
- Inspect and maintain the trimmer regularly. Have the trimmer repaired only by an authorised repairer.
- Inspect the hedge or bushes for foreign objects like wire fences
- Keep your hands and feet away from the cutting area at all times.
- Always hold the trimmer at a safe distance from the body.
- Always wear protective goggles.
- Always wear gloves.
- Only use the trimmer in daylight.
- Ensure the ventilation openings are clear of debris at all times.
- Ensure there are no people or animals within 5 metres of your trimming area.
- Remove the plug from the power socket before attempting any maintenance.
- After use the tool should be stored so that the blade is not exposed.
- Hold the power tool by insulated gripping surfaces only, because the cutter blade may contact hidden wiring. Cutter blade contacting a "live" wire may make exposed metal parts of the power tool "live" and could give the operator an electric shock.

## ADDITIONAL SAFETY WARNINGS FOR CORDLESS HEDGE TRIMMER

- Do not charge hedge trimmer in rain, or in wet locations.
- Do not use battery-operated hedge trimmer in rain.
- Remove or disconnect battery before servicing, cleaning, or removing material from the hedge trimmer.
- Do not dispose of the battery(ies) in a fire. The cell may explode. Check with local codes for possible special disposal instructions.

## SAFETY WARNINGS FOR BATTERY

- Do not open the battery. Danger of short circuiting.
- Protect the battery against heat, e. g., against continuous intense sunlight, fire, water, and moisture. Danger of explosion.
- In case of damage and improper use of the battery, vapours may be emitted. Ventilate the area and seek medical help in case of complaints. The vapours can irritate the respiratory system.
- Use the battery only in conjunction with your SnapFresh product. This measure alone protects the battery against dangerous overload.
- The battery can be damaged by pointed objects such as nails or screwdrivers or by force applied externally. An internal short circuit can occur and the battery can burn, smoke, explode or overheat.

## SAFETY WARNINGS FOR CHARGER

### Intended use

Charge only BBT-DC20A and BBT-DC40A type rechargeable battery packs with the charger. Other types of batteries may burst causing personal injury and damage.

- The appliance is not to be used by persons (including children) with reduced physical, sensory or mental capabilities, or lack of experience and knowledge, unless they have been given supervision or instruction.
- Children being supervised not to play with the appliance.
- Do not recharging non-rechargeable batteries!
- During charging, batteries must be placed in the well ventilated area!

### Electrical safety



Always check that the voltage of the power supply corresponds to the voltage on the rating plate.



## MACHINE INFORMATION

### Intended use

This hedge trimmer is only intended for cutting branches from shrubs, bushes, ornamental plants and hedges.



## TECHNICAL SPECIFICATIONS

Model No.	BBT-YOD01	Model Number	BBT-DC20A
Rated voltage	20V	Battery type	Lithium-ion
No load speed	1400/min	Voltage	20V 
Cutting length	560mm	Capacity	2.0 Ah
Cutting width	14mm	Recommended charger	BBT-YFT20V
Weight	2.15 kg	Weight	0.3 kg
Sound pressure level L <sub>PA</sub>	79.1 dB (A), KpA=3 dB (A)	Model Number	BBT-YFT20V
Sound power level L <sub>WA</sub>	90.1 dB (A), KwA=3 dB (A)	Charger input	100-120V~60Hz 65W
Vibration value	1.937 m/s <sup>2</sup> K=1.5 m/s <sup>2</sup>	Charger output	21V  2.5A
		Charging time 2Ah battery	60 minutes
		Charging time 4Ah battery	120 minutes
		Recommended batteries	BBT-DC20A, BBT-DC40A
		Weight	0.36 kg

Only use the following batteries of the SnapFresh power 20V battery platform. Using any other batteries could cause serious injury or damage the tool.

BBT-DC20A 20V, 2Ah Lithium-ion

BBT-DC40A 20V, 4Ah Lithium-ion

The following charger of the can be used to charge these batteries.

BBT-YFT20V Quick charger

The batteries of the SnapFresh power 20V battery platform are interchangeable with all the SnapFresh power 20V battery platform tools.

### Vibration level

The vibration emission level stated in this instruction manual has been measured. It may be used to compare one tool with another and as a preliminary assessment of exposure to vibration when using the tool for the applications mentioned.

- Using the tool for different applications, or with different or poorly maintained accessories, may significantly increase the exposure level.
- The times when the tool is switched off or when it is running but not actually doing the job, may significantly reduce the exposure level.

Protect yourself against the effects of vibration by maintaining the tool and its accessories, keeping your hands warm, and organizing your work patterns.

# ASSEMBLY

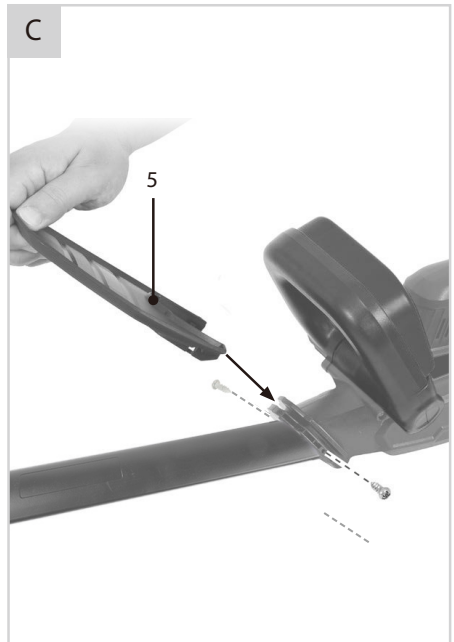
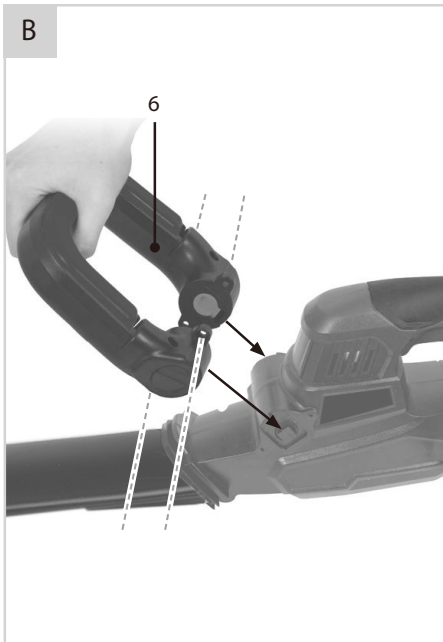
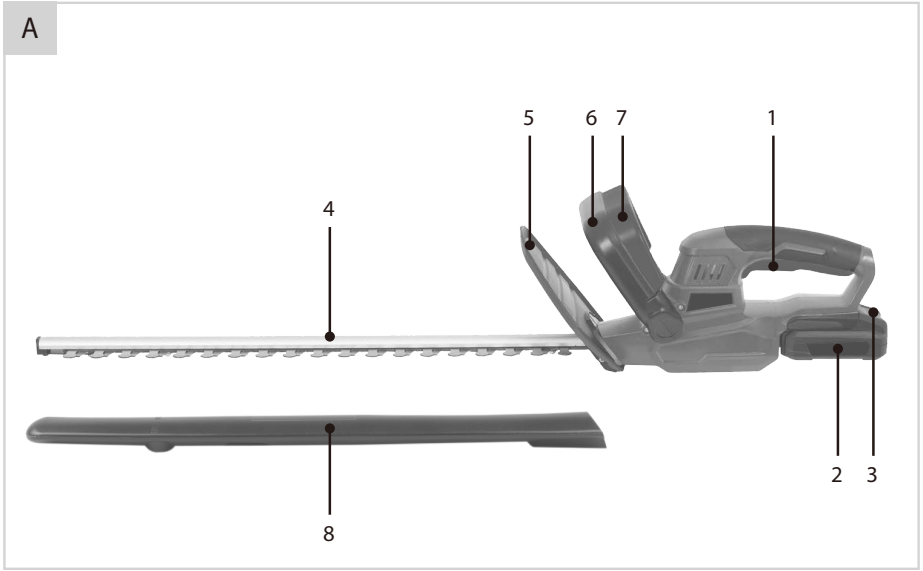

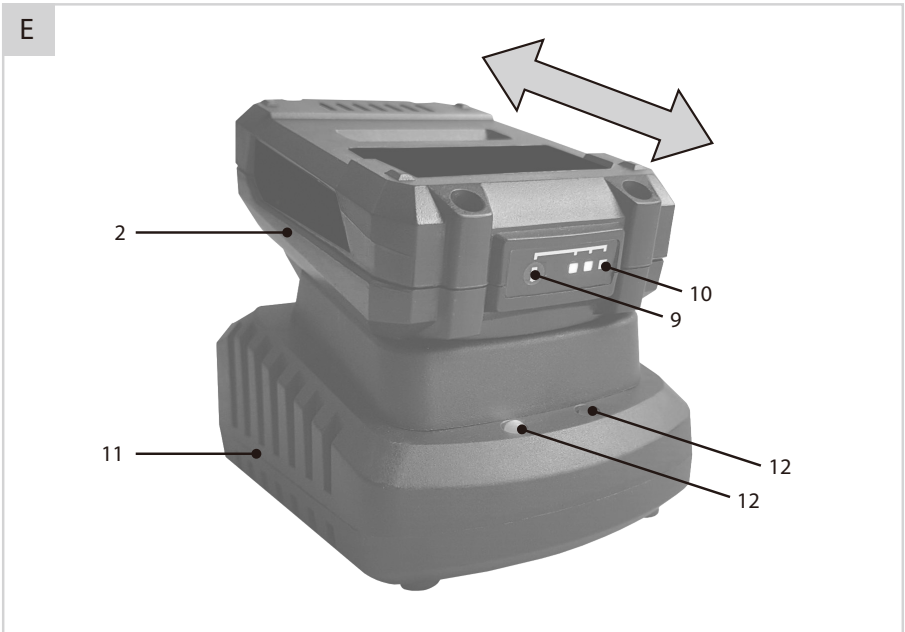
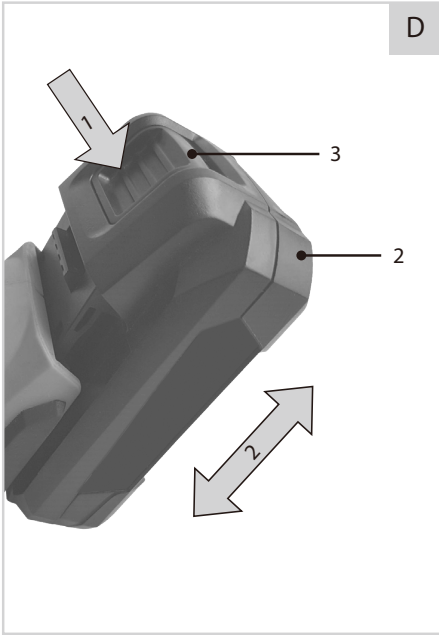



Before any work on the power tool, remove the battery.



The battery must be charged before first use.

## DESCRIPTION

The numbers in the text refer to the diagrams on page 10-11.

- |                          |                                  |
|--------------------------|----------------------------------|
| 1. On/Off button         | 7. Safety switch                 |
| 2. Battery               | 8. Transport protection          |
| 3. Battery unlock button | 9. Battery LED indicators button |
| 4. Cutting blade         | 10. Battery LED indicators       |
| 5. Protection guard      | 11. Charger                      |
| 6. Front handle          | 12. Charger LED indicators       |

### Mounting the front handle (Fig. B)

- Put the front handle (6) on the machine, as shown on figure B.
- Mount the front handle (6) by tightening the four screws.

### Mounting the protection guard (Fig. C)



You may not use the hedge trimmer without the protection guard

- Put the protection guard (5) on the machine, as shown on figure C.
- Mount the protection guard (5) by tightening the two screws.

### Inserting the battery into the machine (Fig. A, D)



Ensure that the exterior of the battery is clean and dry before connecting to the charger or machine.

- Insert the battery (2) into the base of the machine as shown in Fig. D.
- Push the battery further forward until it clicks into place.

### Removing the battery from the machine (Fig. A, D)

- Push the battery unlock button (3)
- Pull the battery out of the machine like shown in Fig. D.

### Checking the battery charging status (Fig. E)

- To check the battery charge status, push the button (9) on battery shortly.
- The battery has 3 lights indicating the charge level, the more lights that burn, the more charge the battery has left.
- When the lights are not burning it means the battery is empty and must be charged immediately.

### Charging the battery with the charger (Fig. E)

- Take the battery (2) from the machine.
- Turn the battery (2) to upside down position and slide it onto the charger (11) as shown in Fig. E.
- Push the battery until it is fully pushed into the slot.
- Plug the charger plug into an electrical outlet and wait for a while. The LED indicators (12) on the charger (11) will lighten up and show the charger status.

The charger has 2 LED indicators (12) which indicate the status of the charging process:

Red LED Status	Green LED status	Charger status
Off	Off	No power
Off	On	Standby mode: - No battery is inserted or, - Battery inserted but charging has finished
On	Off	Battery charging in progress

- Fully charging the 2Ah battery may take up to 60 minutes.
- Fully charging the 4Ah battery may take up to 120 minutes.

After the battery is fully charged remove the charger plug from the outlet and remove the battery from the charger.



When the machine is not being used over a longer period of time it is best to store the battery in charged condition.

## OPERATION



Before using, always visually inspect to see that the blades, blade bolts and cutter assembly are not worn or damaged.



You may not use the hedge trimmer without the protection guard.



Always use both hands to hold the hedge trimmer and keep it away from your own body.

### Using your hedge trimmer

- For your own safety and for best results read the following user advice and do not use this product for anything other than its intended purpose.
- This hedge trimmer is made for cutting hedges and bushes. All other use that is not specifically allowed in this manual may lead to damage to the hedge trimmer or injury to the user.

### Switching on and off (Fig. A)

- To switch the trimmer on, press the safety switch (7) and the start switch (1) at the same time.
- To switch off, release one or both switches.

### Trimming a hedge - best method

- Apart from hedges the hedge trimmer may also be used for cutting bushes.
- The best cutting effect is achieved when holding the blade at an angle to the of approx. 15°.
- The opposite rotating knives cut on both sides, and it is therefore possible to trim the hedge in both directions.
- The side of the hedge are trimmed using curved shaped movements from the bottom and upwards.
- Ideally a hedge should be wider at the bottom than the top. This will improve light penetration, keeping the hedge healthy. If possible, trim both sides of the hedge.
- When trimming the sides of the hedge, trim from the bottom upwards. This will ensure there are no hedge trimmings obscuring or interfering with your cut strokes. The blade should not be forced to cut too deep. Cut lightly through the surface of the hedge.
- When trimming the top of the hedge, trim away from you but do not over-reach. It is much wiser and safer to move along and cut within your reach remaining on two feet at all times.

### Safety transport

The hedge trimmer has a transport protection Cover (8) for safe transportation of the machine.

## MAINTENANCE



Before cleaning and maintenance, always switch off the machine and remove the battery pack from the machine.

Clean the machine casings regularly with a soft cloth, preferably after each use. Make sure that the ventilation openings are free of dust and dirt. Remove very persistent dirt using a soft cloth moistened with soapsuds. Do not use any solvents such as gasoline, alcohol, ammonia, etc. Chemicals such as these will damage the synthetic components.

### Cutting blade

- Always wear gloves when handling or cleaning the cutting blade.
- Clean the cutting blade and spray with a protective oil after every use. We recommend lubricating the cutting blade with protective oil at regular intervals during long working periods.
- Visually inspect the condition of the cutting blade. Check that the screws are firmly seated in the cutter bar.
- Ensure that the blade guard is fitted on the machine.

### Storage

The hedge trimmer should be kept in a safe, dry place, well out of the reach of children. Do not place other objects on top of it.

## ENVIRONMENT



Faulty and/or discarded electrical or electronic apparatus have to be collected at the appropriate recycling locations.

## WARRANTY

Ningbo Babytec Technology Co., Ltd (Hereinafter referred to as Babytec) warrants this product against defects in materials and/or workmanship under normal use for a period of ONE (1) YEAR from the date of purchase by the original purchaser ('Warranty Period').

The following circumstances are excluded from this guarantee:

- Repairs and or alterations have been made or attempted to the machine by unauthorized service centers;
- Normal wear and tear;
- The tool has been abused, misused or improperly maintained;
- Non-original spare parts have been used.

If a defect arises and a valid claim is received within the Warranty Period, at its option, Babytec will either 1) repair the defect at no charge, using new or refurbished replacement parts, or 2) replace the product with a new product that is at least functionally equivalent to the original product, or provide a store credit in the amount of the purchase price of the original product. A replacement product or part, including a part installed in accordance with instructions product by Babytec, assumes the remaining warranty of the original product. When a product or part is exchanged, any replacement item becomes your property and the replaced item becomes Babytec's property. When a store credit is given, the original product must be returned to Babytec and becomes Babytec's property. To obtain warranty service, e-mail Babytec Warranty Service at [support@snapfresh-tools.com](mailto:support@snapfresh-tools.com). Please be prepared to describe the product that needs service and the nature of the problem.



+1 833 635 0955

(Monday - Friday 9 a.m. - 5 p.m. EST 6 a.m. - 2 p.m. PST)