

STEP:01 - GLUE WALLS

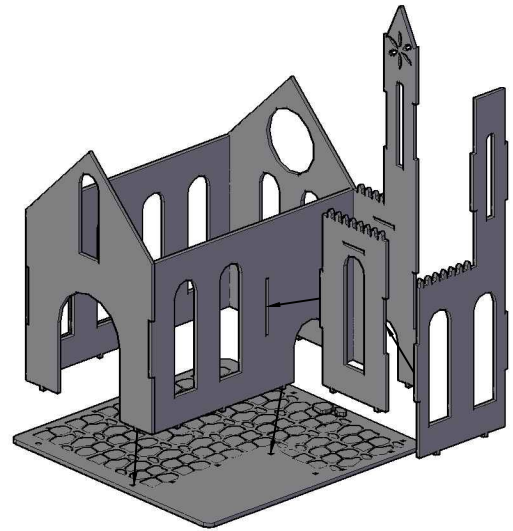

STEP:02 - GLUE WALLS AND LEAVE MODULAR TO BASE (OPTIONAL)

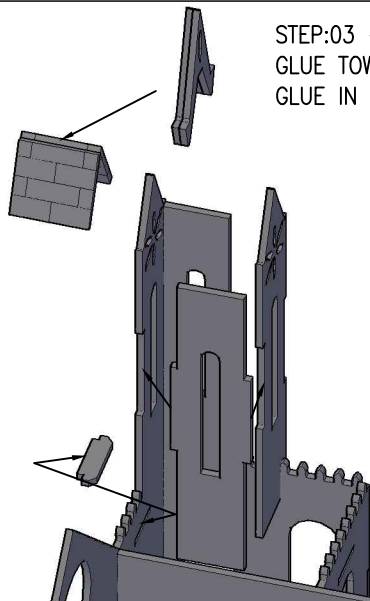

STEP:03 - FINAL WALLS GLUE IN
GLUE TOWER ROOF AND SPEAR
GLUE IN FLOOR SUPPORTS

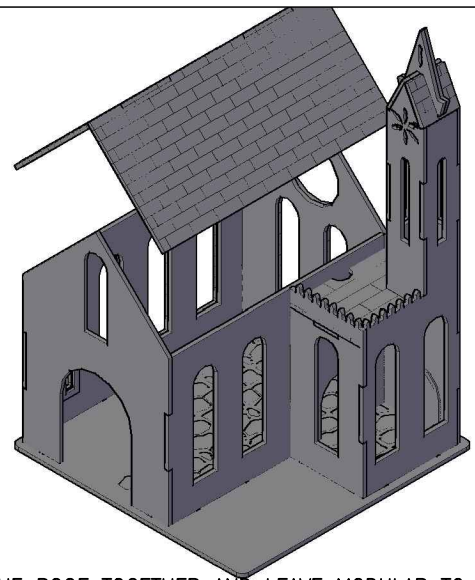

STEP:04 - GLUE ROOF TOGETHER AND LEAVE MODULAR TO BUILDING

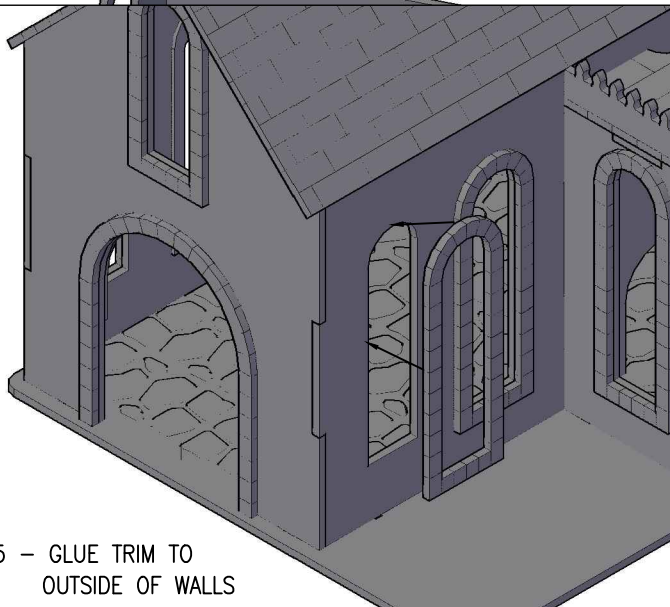

STEP:05 - GLUE TRIM TO
OUTSIDE OF WALLS

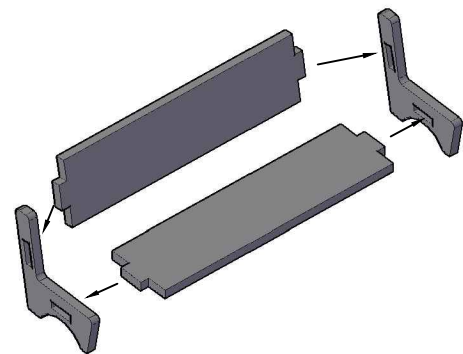

STEP:06 - GLUE TOGETHER PEWS