



APPLICATION MANUAL

Rivet

PRECIOSA



Mechanical Applications

Now available with our premium MC Chaton MAXIMA crystals, Rivets give the perfect edge to shoes, hand-bags and textiles. This product range is easily applied via Fly Press or manual applicator.

PRODUCT OVERVIEW

JEWELLERY APPLICATION	MANUAL APPLICATOR	FLY PRESS
MC Chaton MAXIMA Rivet	✓	✓

CHECKING THE CARRIER MATERIAL THICKNESS AND SELECTING THE RIVETS AND DIES

Rivets can be applied to various materials using Back Parts. Please note the material thickness when selecting the Rivets.

MC CHATON MAXIMA RIVET	ART. NO.	SIZE	MATERIAL THICKNESS*
MC Chaton MAXIMA Rivet	7193 2018	ss 18	2.0 – 2.5 mm
MC Chaton MAXIMA Rivet	7193 2029	ss 29	2.0 – 2.5 mm
MC Chaton MAXIMA Rivet	7193 2034	ss 34	2.0 – 2.5 mm

* If the carrier material proves too thick, or is made up of several layers, it is recommended to punch a hole before application.

MACHINES, TOOLS AND AIDS

PRECIOSA offers a hand tool with upper and lower dies for Rivets, sizes ss18 – ss34.



The Fly Press is an easy way to mechanically apply Rivets. This tool can be provided by PRECIOSA (SAP 4301631).



PRECIOSA can also provide a manual applicator. (SAP 4271319).



Die set for MC Chaton MAXIMA Rivet. This set can be provided by PRECIOSA (SAP 4290881).

Mechanical Application

Able to be bolted down to a flat surface, the Fly Press is a sturdy and reliable tool suitable for frequent application of Rivets.

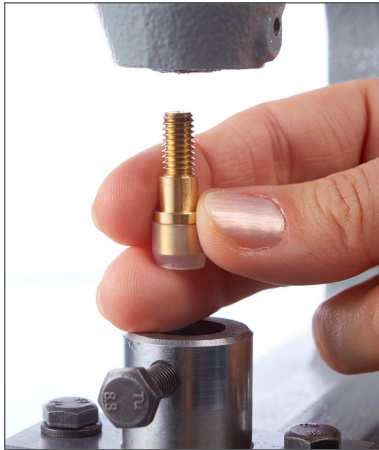

1. Placemet of the upper die.

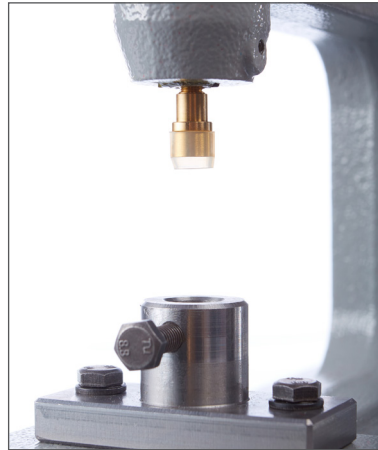

2. The upper die needs to be screwed in tightly.



3. Placement of the lower die.



4. Tighten the lower die.



5. Attach the rivet to the upper die.



6. Place the back side of the Rivet on the lower die.



7. Application on leather.



8. Applied Rivet from the top.



9. Applied Rivet from the bottom.

Manual Application

The manual applicator is an alternative, handy tool for applying Rivets that also doubles as an applicator for Pins when used with the corresponding die set.



1. Placemet of the upper die.



2. Placement of the lower die.



3. Tighten the lower die.



4. Attach the rivet to the upper die.



5. Place the back side of the Rivet on the lower die.



6. Design created using a manual applicator.



7. Applied Rivets on a leather band.

MC CHATON MAXIMA RIVET

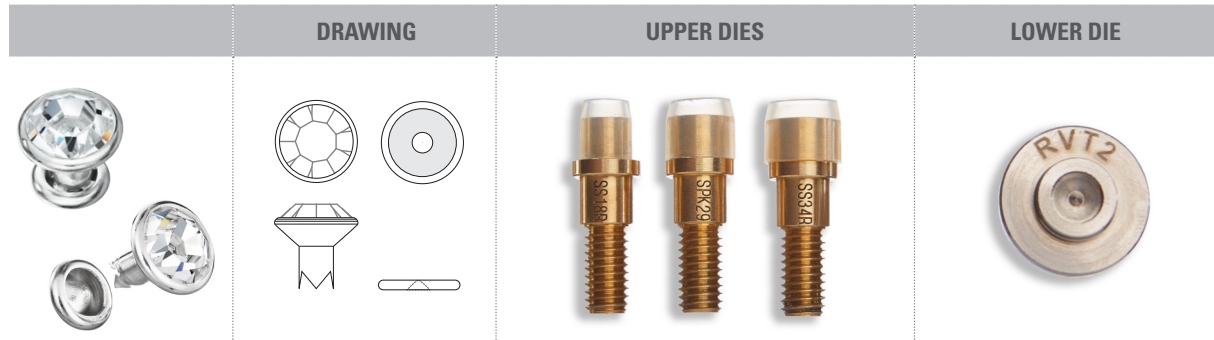

USEFUL TIPS

OPTIMUM PRODUCT/DIE ALIGNMENT

It is important to make sure that the Rivets are properly aligned with the dies, so as to avoid any problems during the mechanical application process.

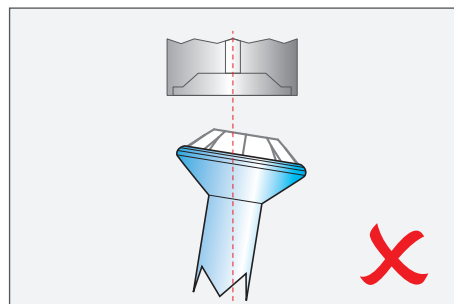
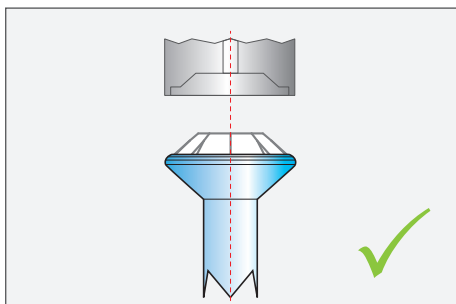

MINIMUM GAPS

During application, the Rivet is entirely surrounded by the upper die. To prevent neighbouring Rivets from being damaged, be sure to check the minimum space required by the die when calculating the space between each Rivet.

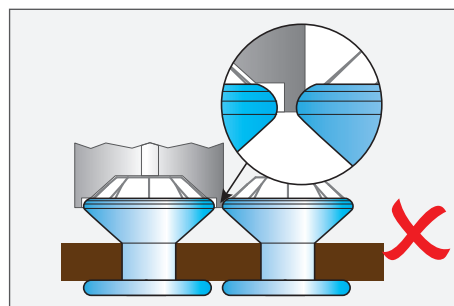
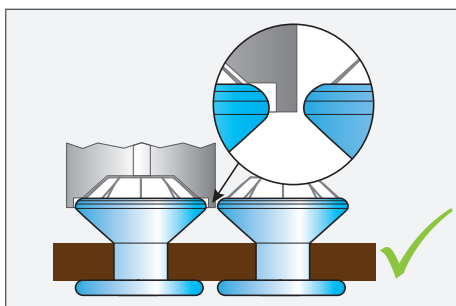

Important Information

POSSIBLE PROBLEMS, THEIR CAUSES AND RECOMMENDATIONS

The table below lists possible problems encountered during mechanical application, followed by a list of probable causes and how to fix them.

PROBLEM	CAUSE
The Rivets are not properly attached to the carrier material.	1, 2, 3, 4, 5
The carrier material ripples or crinkles.	2, 3, 4, 5
The dies cannot be inserted into the fly press.	3, 6, 7, 8
The dies cannot be unscrewed.	6, 8, 9
The Rivets' crystals break.	2, 3, 4, 5, 10

CAUSE	RECOMMENDATION
1 The pressure is too low.	Increase the pressure when applying the product and adjust the stop.
2 The carrier material is too thick or there are too many layers.	A hole can be pre-punched.
3 The die (the spare part) of the upper die is defective or improperly attached.	Check the die (the spare part) and replace or repair it if necessary.
4 The wrong dies are being used.	Adjust dies according to Rivet.
5 The dies are not attached correctly.	Check to make sure the Rivets are placed properly on the dies, then slowly turn the Fly Press handle to make sure that the upper and lower parts of the applicator meet as they should.
6 The Fly Press and dies do not fit together.	Check the thread size of both the Fly Press and the upper die to make sure the sizes match.
7 The upper die cannot be attached.	Check the fastening screw on the upper die; it may be screwed too tightly.
8 The die (the spare part) may be damaged.	Check to see if the die is defective and replaces if necessary.
9 The screw on the upper die has broken off.	Carefully loosen the screw using pliers. It is necessary to oil and centre the die once in a while.
10 The pressure is too high.	Use a bit less pressure when applying the Rivets and adjust the stop.

CARE INSTRUCTIONS

Proper care will ensure the high quality and durable application of PRECIOSA Rivets.

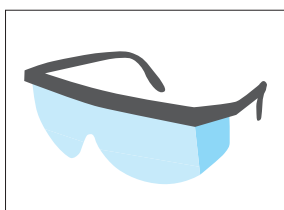

It is recommended to wear protective eyewear during mechanical application to avoid any injury.

GENERAL RECOMMENDATIONS

FASHION JEWELLERY STONES

FLAT BACK STONES

Stones with coatings
— use only gentle
wash cycle (30 °C).



Turn inside out, choose a gentle wash cycle and use mild laundry detergent. To protect the crystals as much as possible, the use of a soft wash bag is recommended.

Round
Stones,
Channel

Fancy
Stones,
Ball

No Hotfix
Stones

Hotfix
Stones

Sew-on
Stones



Turn inside out and use mild laundry detergent.



Do not wash!



Chlorine bleach may be used.



Do not use chlorine bleach!



Turn inside out and dry at reduced temperature.



Do not tumble dry!



Iron inside out using a silk/polyester viscose setting. Ironing the textile inside out and using a pressing cloth is recommended.



Iron inside out using a wool setting.



Do not iron! Do not iron directly over the crystals.

To protect the crystals as much as possible, the use of a soft wash bag is recommended.



The textile can be gently dry-cleaned using perchlorethylene. Turn inside out.



The textile can be gently dry-cleaned using hydrocarbon.



The textile will withstand gentle professional wet cleaning. Turn inside out.



The textile may not be dry-cleaned.



**BEADS AND
PENDANTS**

**NACRE
PEARLS**

**FASHION AND FASHION
JEWELLERY COMPONENTS**

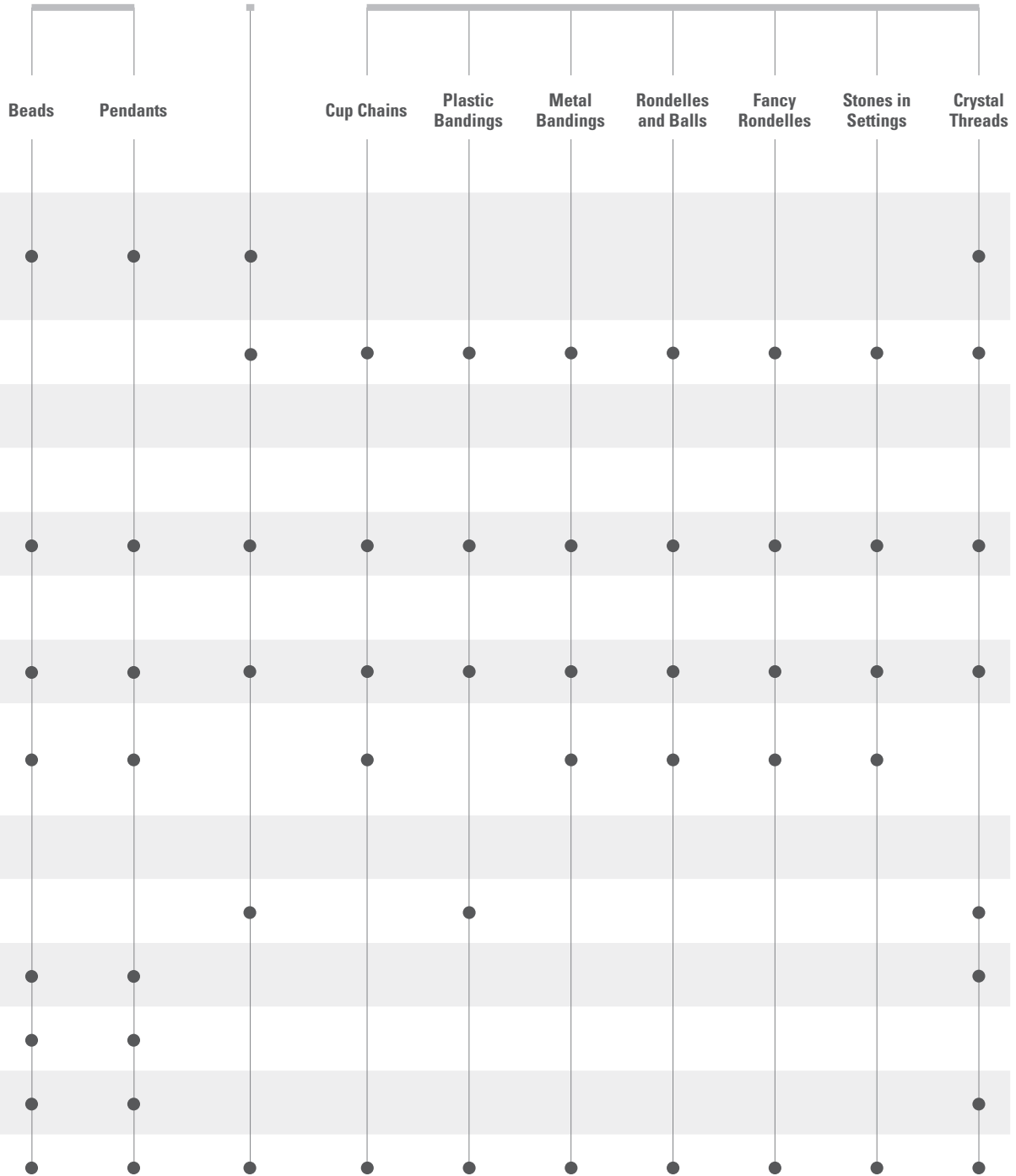

Preciosa Components

A Member of the Preciosa Group

Preciosa Group is a global leader in products *manufactured from crystal*. From the world famous Czech Beads and Crystal Components used in fashion industry, to tailor made Lighting projects for luxury hotels, royal palaces and yachts, the true craftsmanship of crystal production has been present in Bohemia since 16th century.

PreciosaComponents.com