

# Have Any Questions?

mopio

Chat with us at [www.mopio.com#chat](https://www.mopio.com#chat) | We will be online from 10am to 7pm PST timing. Alternatively you can contact us at [help@mopio.com](mailto:help@mopio.com)

## Shop With Confidence



Norwin Executive Desk

I was able to organize some of Bryce's gaming equipment with the Norwin Executive Desk by @mopioinc! I always tell Bryce his rainbow equipment is cramping my neutral vibe  
- L



I am so very pleased with this coffee table. It looks great in our home and I love the nice walnut style. It was so easy to assemble and it's such good quality. The doors on both sides slide which the little kid in me was super entertained by. Highly recommend this piece!  
- L.D



Haylee Coffee Table

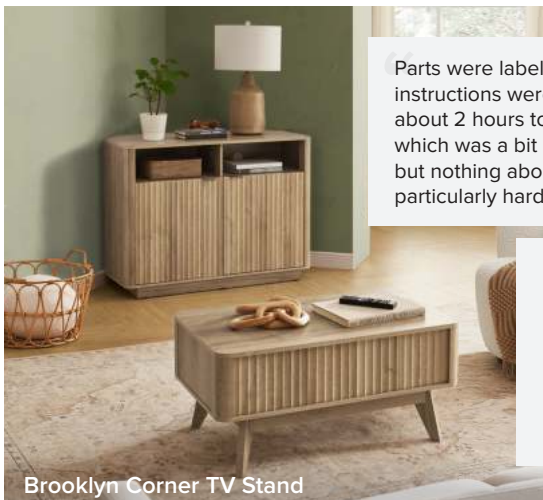

Brooklyn Corner TV Stand

Parts were labeled properly and the instructions were fairly clear. It took me about 2 hours to assemble on my own, which was a bit longer than I expected, but nothing about the assembly was particularly hard.

The colour of the oak laminate was in line with the pictures and the sizing was as described. All in all, it was value for money and it uplifted our living room with its waveform panel design and gave it the mid century modern touch I wanted.  
- L.L



# ENSLEY TV STAND, 46"

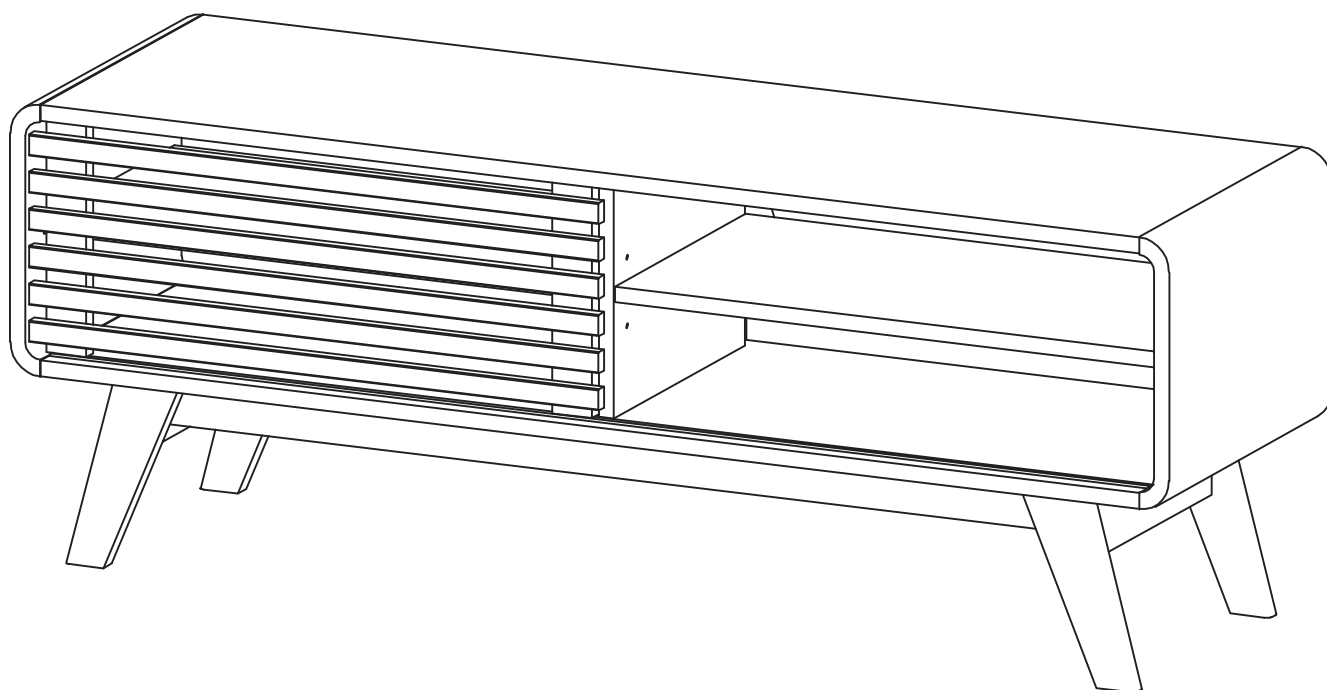

ASSEMBLY INSTRUCTIONS

**mopio**<sup>®</sup>

# Join us at Mopio Club!

We've got more for you. Be part of **Mopio Club** and enjoy:

- Privileged Customer Care
- 10% Off Your Next Purchase (no min spend)
- 1-Year Free Warranty
- Early Access To Upcoming Launches

To find out more: [www.mopio.com/club](http://www.mopio.com/club)



## Contact Us!

For any enquiries or issues regarding your purchase, chat with us  
at [www.mopio.com#chat](http://www.mopio.com#chat).

 [help@mopio.com](mailto:help@mopio.com)

  [@mopioinc](https://www.instagram.com/mopioinc)

 [www.mopio.com](http://www.mopio.com)

# Before you start...

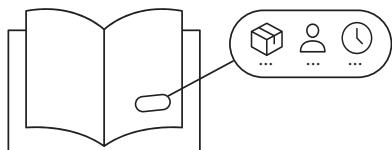

Ensure you have received all cartons and familiarize yourself with the workload. Make sure there are enough helping hands to assist you, and that you have allocated the time required to assemble your new product.

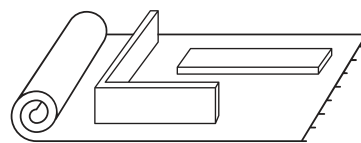

Make sure you have cleared enough space in your home for the assembly. We recommend protecting your floor with a mat or cardboard to avoid scratches during the assembly process.

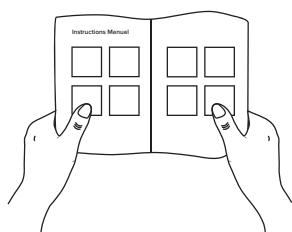

Read instructions carefully and check no parts are missing.

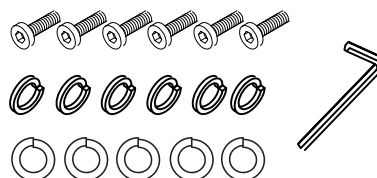

Lay out all hardware on a soft surface so you can easily identify them.

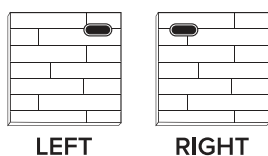

Carefully identify all components in order to differentiate which pieces are left and right.

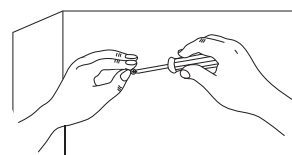

Install your new product carefully following the instructions. Don't skip ahead!

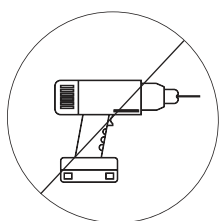

**DO NOT** over tighten screws or use a drill. It will damage the product.



If you need further assistance with assembling your Mopio product, please chat with us at [www.mopio.com#chat](https://www.mopio.com#chat).

# Parts

▶ Watch installation demo video at:  
<https://bit.ly/33q00RF>

- ① x1
- ② x1
- ③ x2
- ④ x1
- ⑤ x2
- ⑥ x2
- ⑦ x2
- ⑧ x2
- ⑨ x2
- ⑩ x2
- ⑪ x1

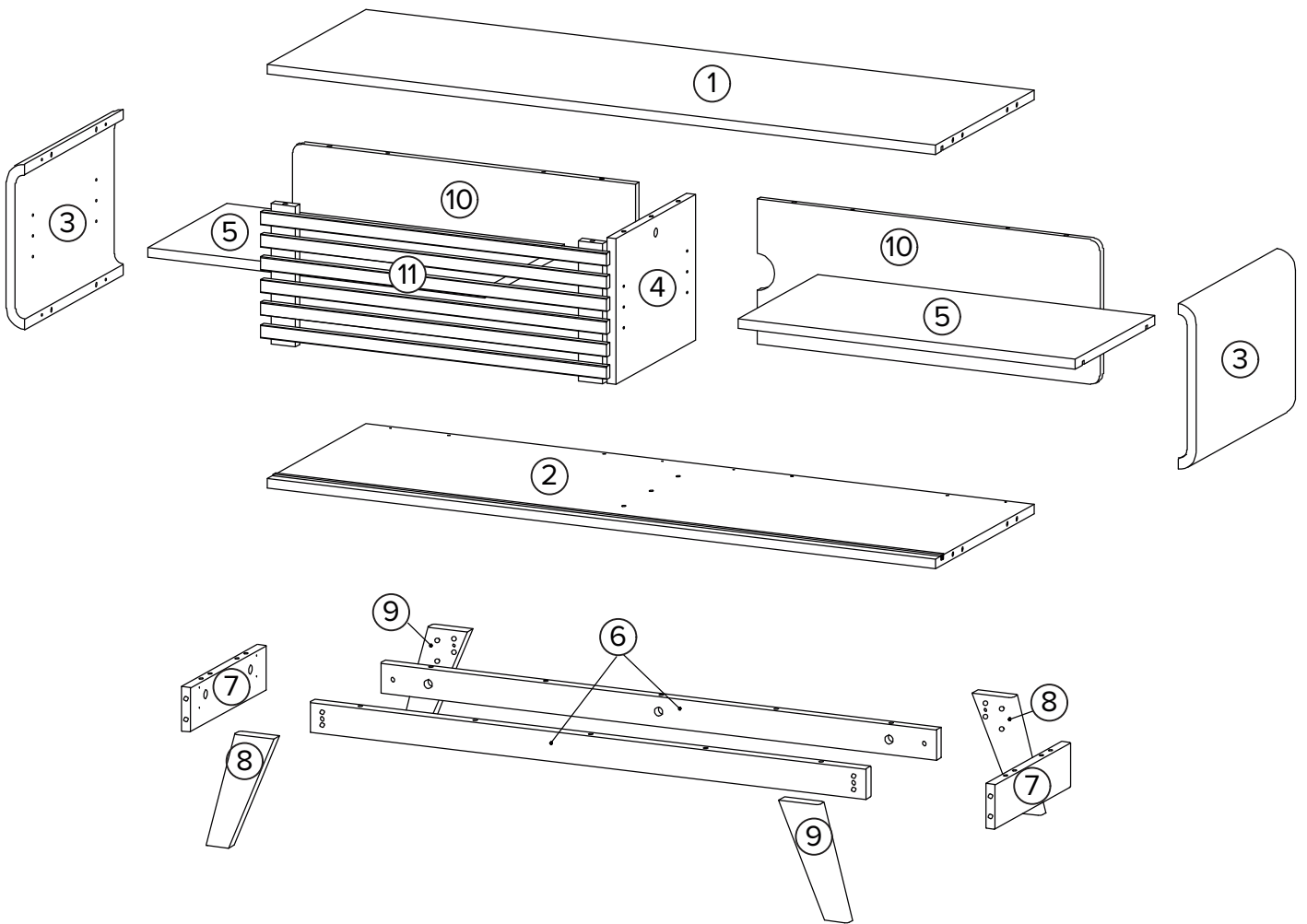

# Hardware



Watch installation demo video at:  
<https://bit.ly/33q00RF>

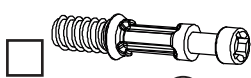

Cambolt  
 Ø 6 x 35 mm

(A)

**x27**

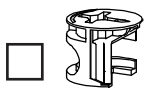

Camlock Big  
 Ø 15 mm

(B)

**x19**



Camlock Small  
 Ø 12 mm

(C)

**x8**

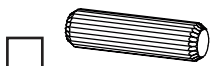

Dowel Big  
 Ø 8 x 30 mm

(D)

**x36**



Dowel Small  
 Ø 6 x 30 mm

(E)

**x8**



Allen Key  
 L 4

(F)

**x1**



Screw  
 M 7 x 50 mm

(G)

**x1**



Screw  
 M 6 x 12.5 mm

(H)

**x10**



Anti Deflection  
 Bar

(I)

**x1**

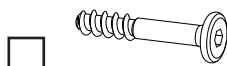

Screw  
 M 6.4 x 35 mm

(J)

**x4**

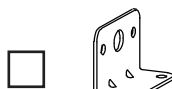

Bracket

(K)

**x4**



Screw  
 M 4.5 x 12.5 mm

(L)

**x8**

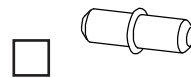

Shelf Pin  
 Ø 5 x 15 mm

(M)

**x8**



Buffer  
 Ø 8 mm

(N)

**x2**

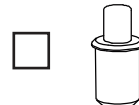

Pin Sliding  
 Top

(O)

**x2**

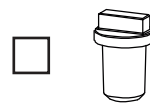

Pin Sliding  
 Bottom

(P)

**x2**

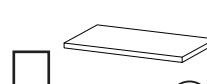

Floor  
 Protector

(Q)

**x4**



There are inner box(es) that include components required to complete this assembly.



Please do not completely tighten all the hardware, until each assembly step is complete.



Before discarding the packaging, please use the checklist to ensure that you have all the parts required to assemble your product. Please kindly note you will need the original package if you want to return the product later.



If parts are missing or damaged, we will gladly ship your replacements parts free of charge. Please contact us at [help@mopio.com](mailto:help@mopio.com) or chat with us at [www.mopio.com#chat](https://www.mopio.com#chat).



**x1**



**x2**



**60 mins**

# Step 1

Ensure your floor is properly protected, then take out board No.1, No.2, and No.4. We recommend using cardboard or foam to lift up the boards so as to avoid scratches due to assembly actions.

Screw cambolt A to board No. 1 and No.2 (don't over screw).

Plug in dowel D into side holes of board No.1, No.2 and No.4.

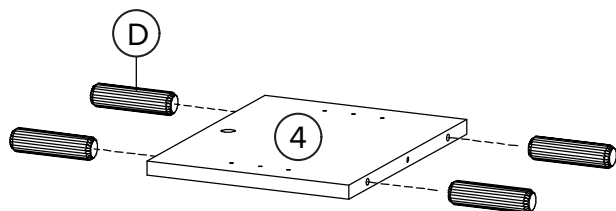
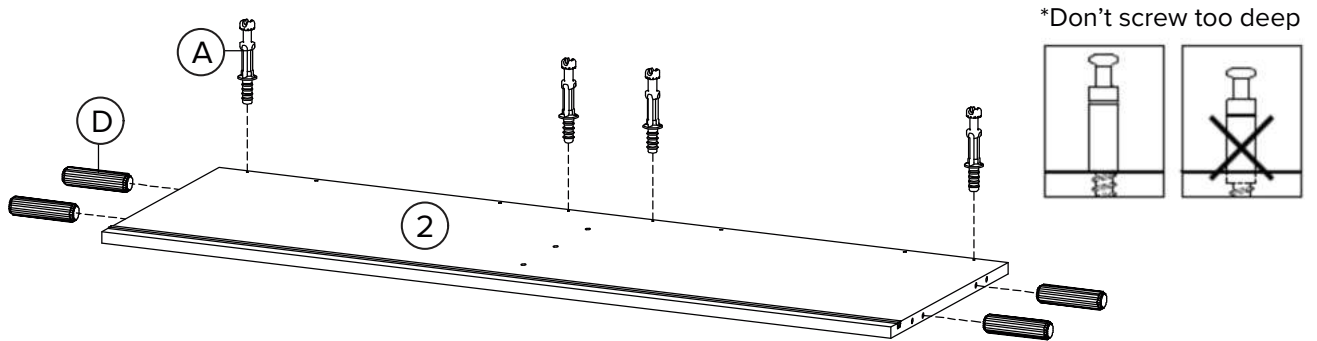
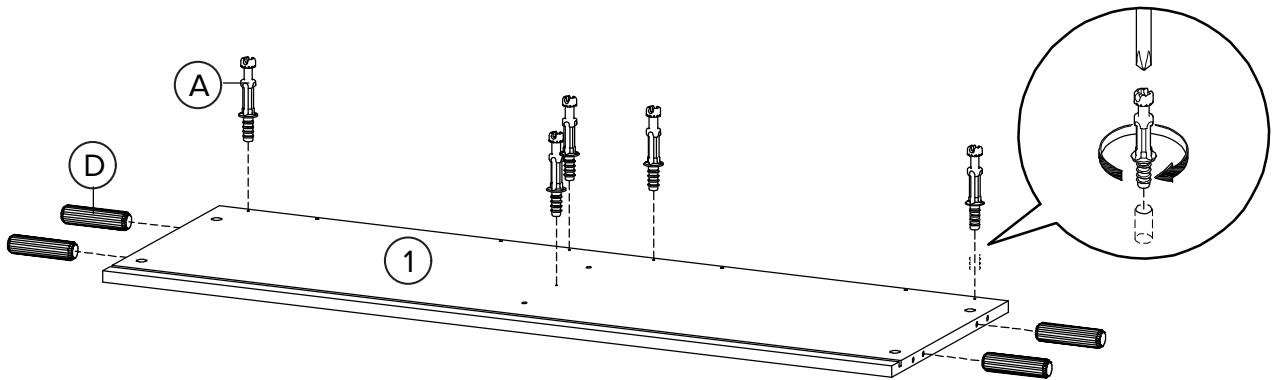

 **Missing parts? Or feeling stuck?**  
Chat with us at [www.mopio.com/#chat](https://www.mopio.com/#chat)

 **Watch demo video at:**  
<https://bit.ly/33q00RF>

## Step 2

Take out 2 pieces of board No.3. Screw cambolt A into the indicated holes and tighten them (don't over screw).

Take out 2 pieces of board No.10. Plug in dowel E to the indicated holes.

\*Don't screw too deep

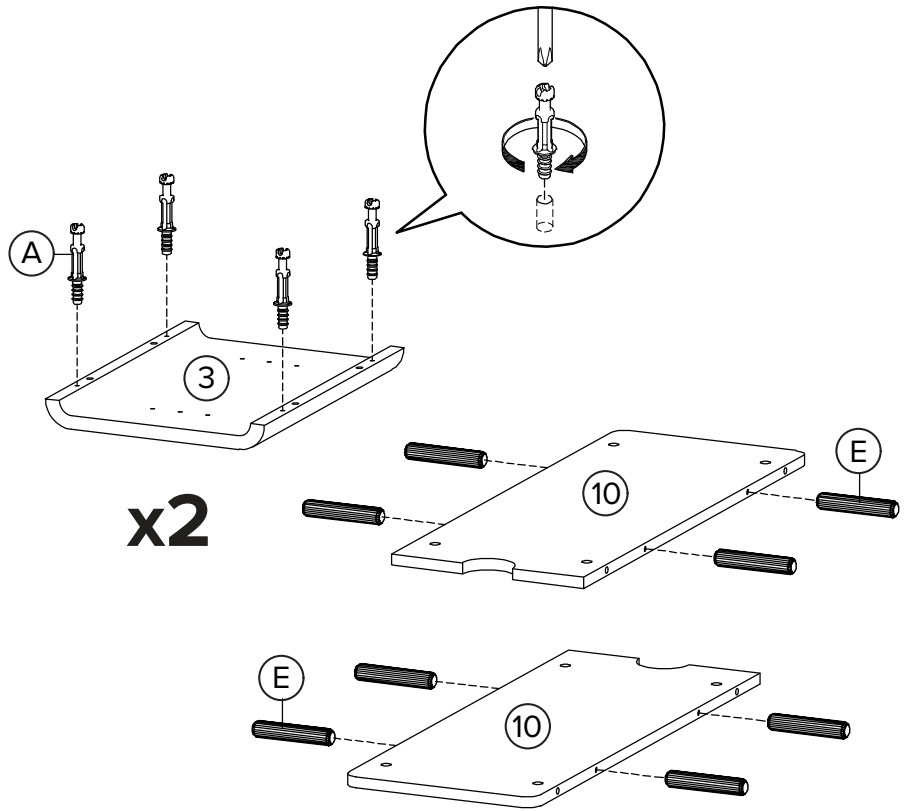
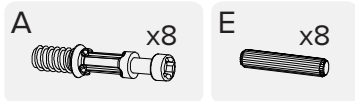
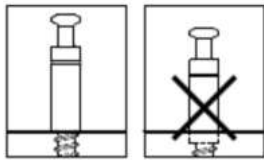

## Step 3

You may require an extra pair of hands to complete this step.

Install board No.4 to the board No.1 by engaging the previously installed cambolt and dowel. Insert camlock B and tighten it with the Allen key provided or a screw driver. Take note carefully of the correct positioning of board No.4 and camlock.

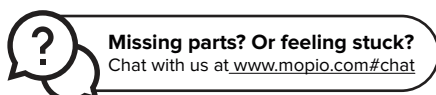
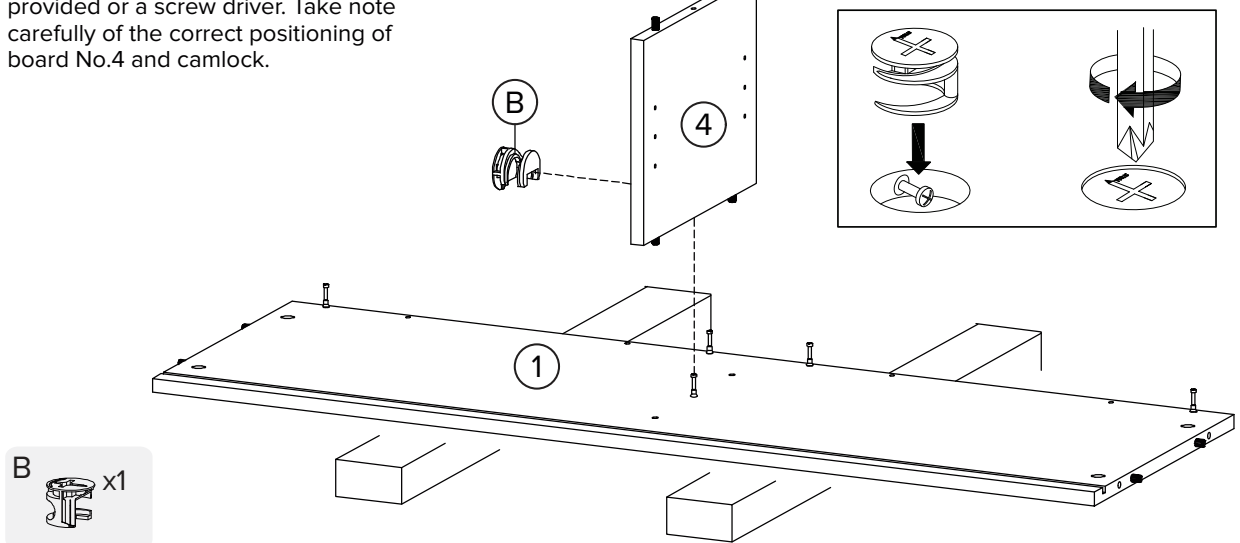

Missing parts? Or feeling stuck?  
Chat with us at [www.mopio.com/#chat](https://www.mopio.com/#chat)



Watch demo video at:  
<https://bit.ly/33q00RF>



## Step 4

Install 2 pieces of board No.10 to the previous construction by engaging the cambolt and dowel. Insert camlock C and tighten it to fix board No.10. Please ensure the correct positioning of board No.10 as illustrated and ensure camlock C is facing outside.

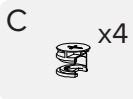
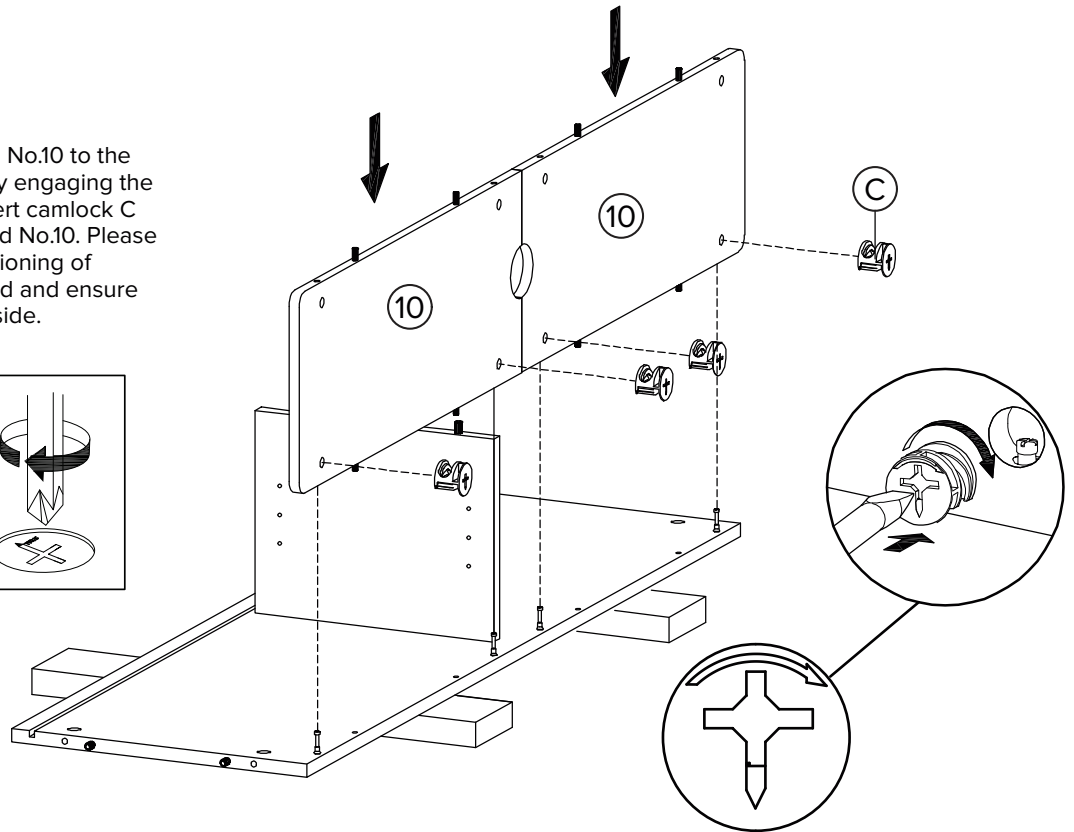
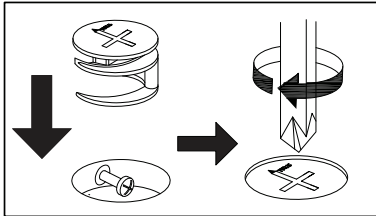

## Step 5

Install board No.2 on top of previous construction by engaging the dowel.

Place screw G to the indicated center position and tighten it to fix the board.

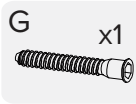
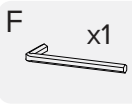
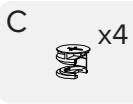
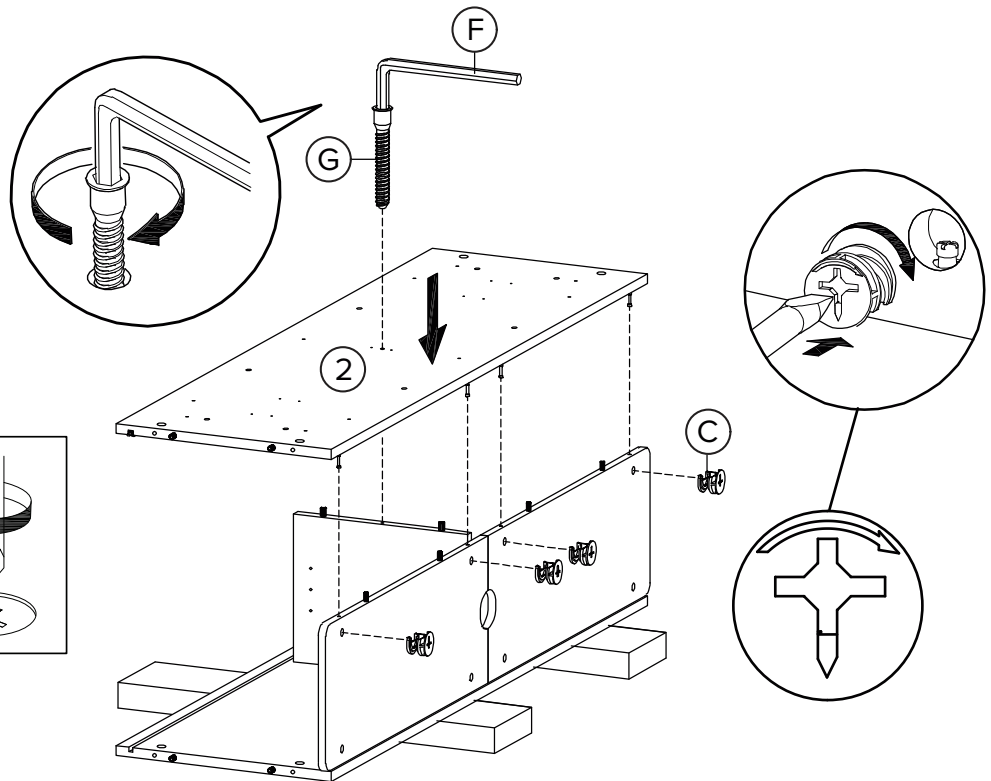
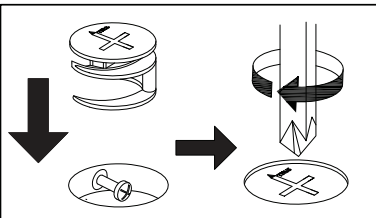

Missing parts? Or feeling stuck?  
Chat with us at [www.mopio.com/#chat](https://www.mopio.com/#chat)



Watch demo video at:  
<https://bit.ly/33q00RF>

## Step 6

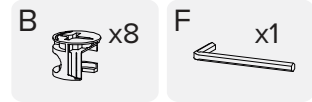

Install 2 pieces of board No.3 to the sides of previous construction by engaging the dowel and cambolt previously installed.

Insert camlock B to indicated positions and tighten it with the Allen key provided or a screw driver.

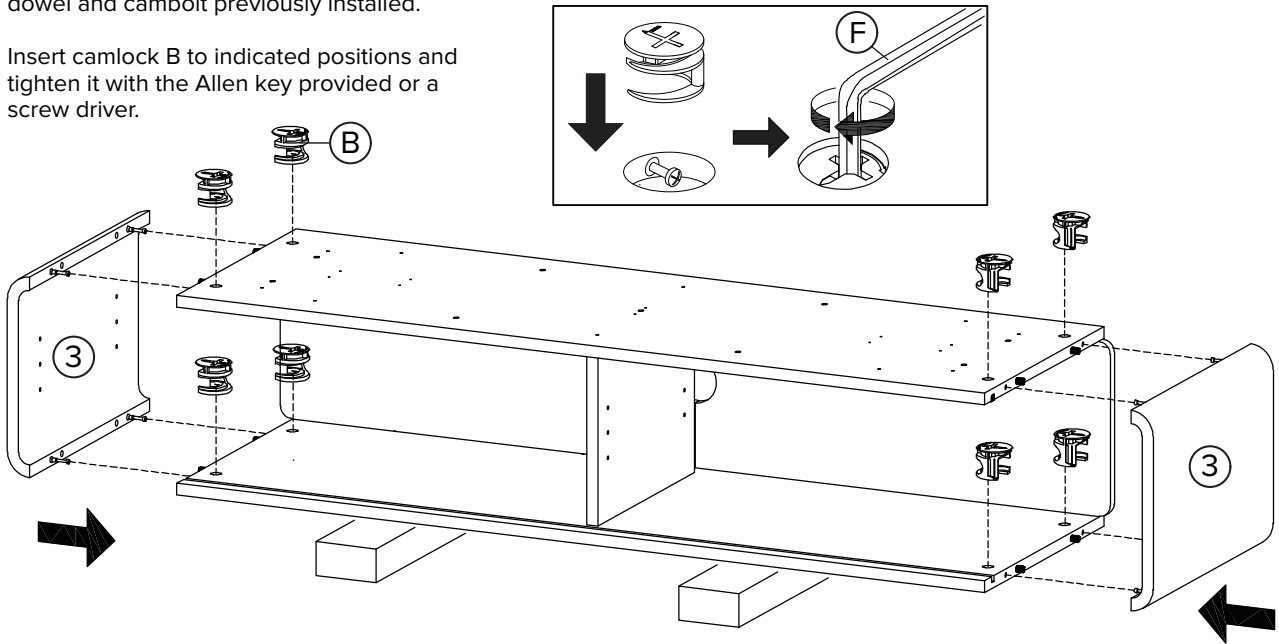

## Step 7

Screw cambolt A to the board No.2 at the indicated locations. Don't screw too deep.

\*Don't screw too deep

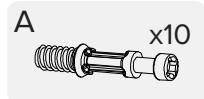
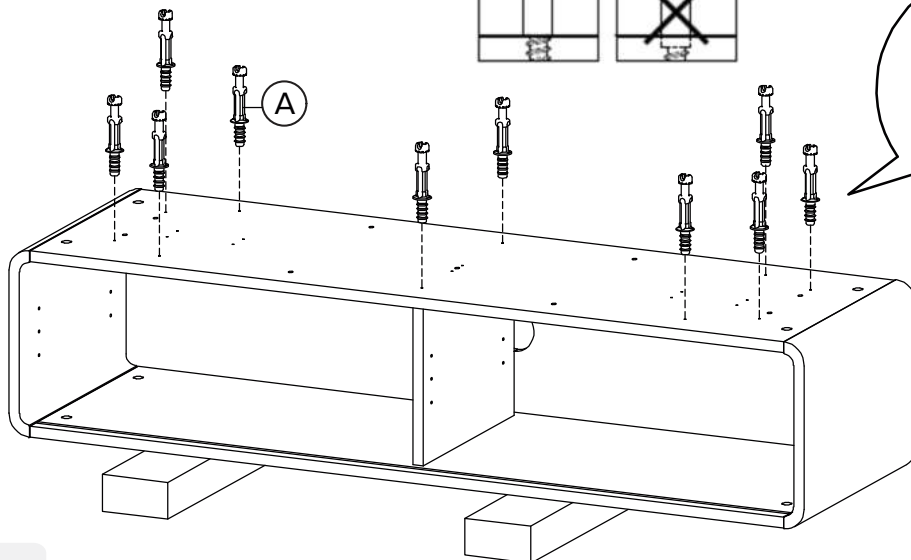
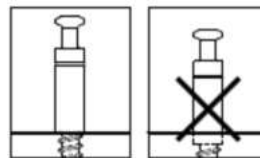

Missing parts? Or feeling stuck?  
Chat with us at [www.mopio.com/chat](https://www.mopio.com/chat)



Watch demo video at:  
<https://bit.ly/33q00RF>

# Step 8

Install the anti-deflection bar I using screw H and tighten the screw to ensure it's in place.

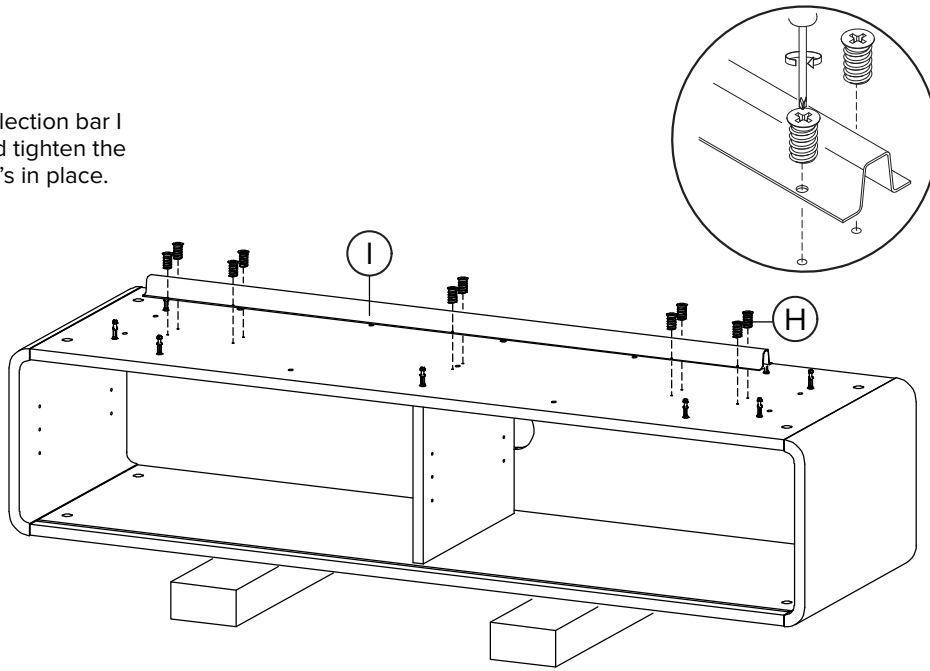

# Step 9

Leg 8 and 9 are packed and connected together. Detach leg 8 and 9 by pulling the leg lightly, rotate it slightly if necessary.

Prepare 2 pieces of leg No.8 and 2 pieces of leg No.9. Plug in dowel D to the side of the legs. Peel floor protector Q and stick to the end of the legs.

Prepare 2 pieces of leg frame No.7. Install bracket K with screw L. Please follow the correct bracket position as indicated in the illustration.

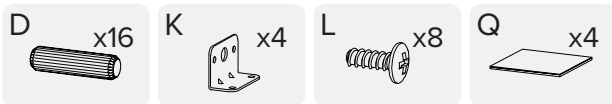
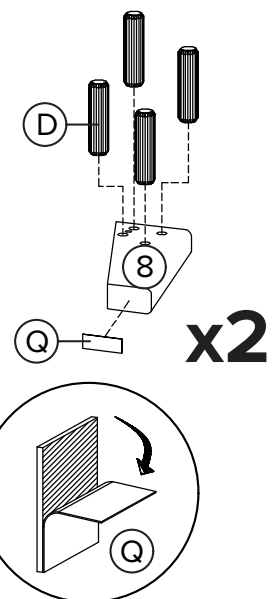
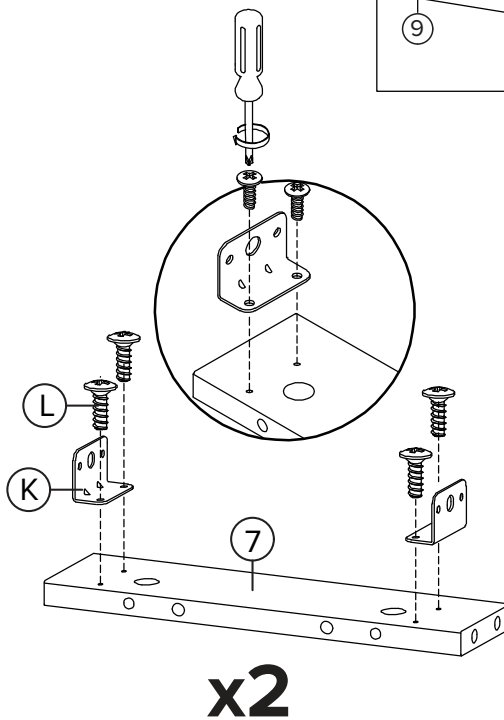
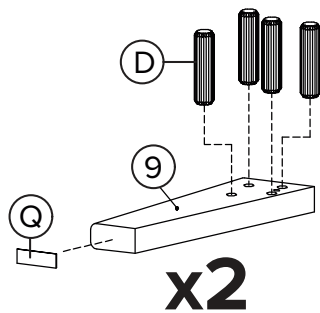
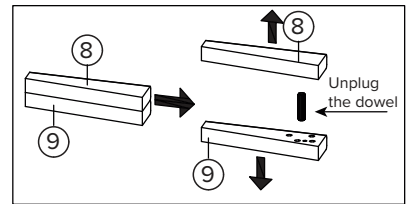

**Missing parts? Or feeling stuck?**  
Chat with us at [www.mopio.com/chat](https://www.mopio.com/chat)

**Watch demo video at:**  
<https://bit.ly/33q00RF>

# Step 10

Take out 2 pieces of leg frame No.6. Place 2 pieces of leg frame No.7 and connect with No.6 as indicated in the illustration.

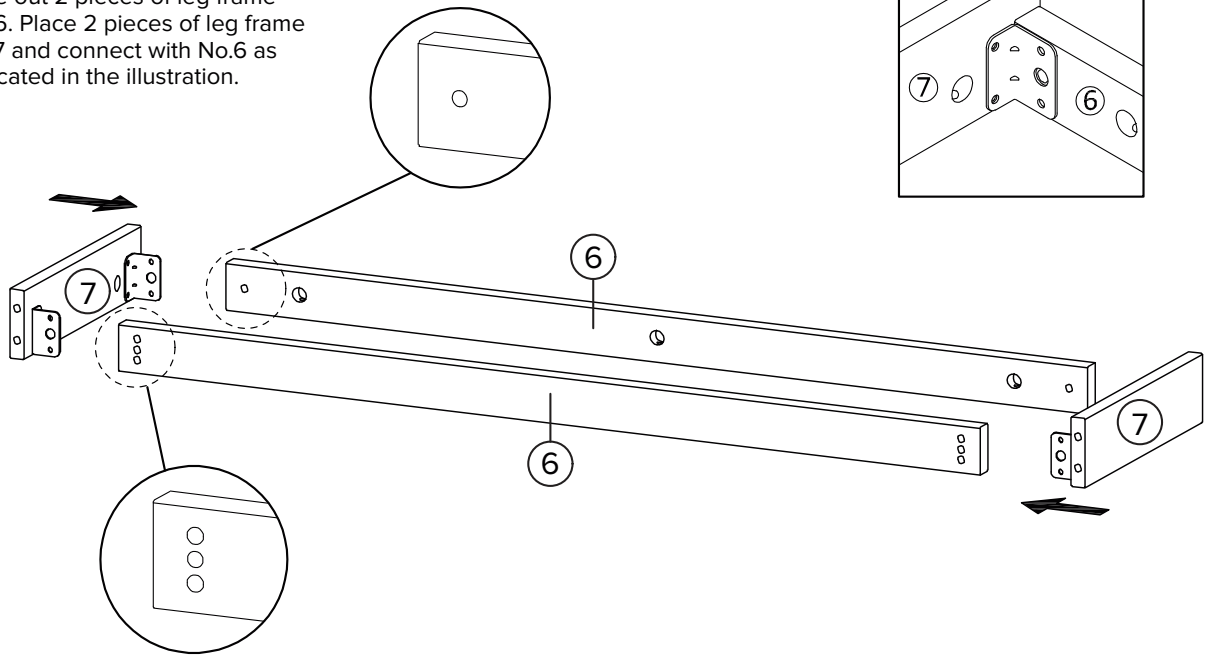

# Step 11

Install leg No.8 and No.9 by engaging the dowel. Please take note of the correct position of each leg according to the illustration.

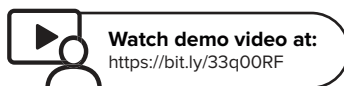
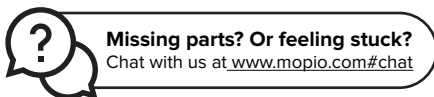
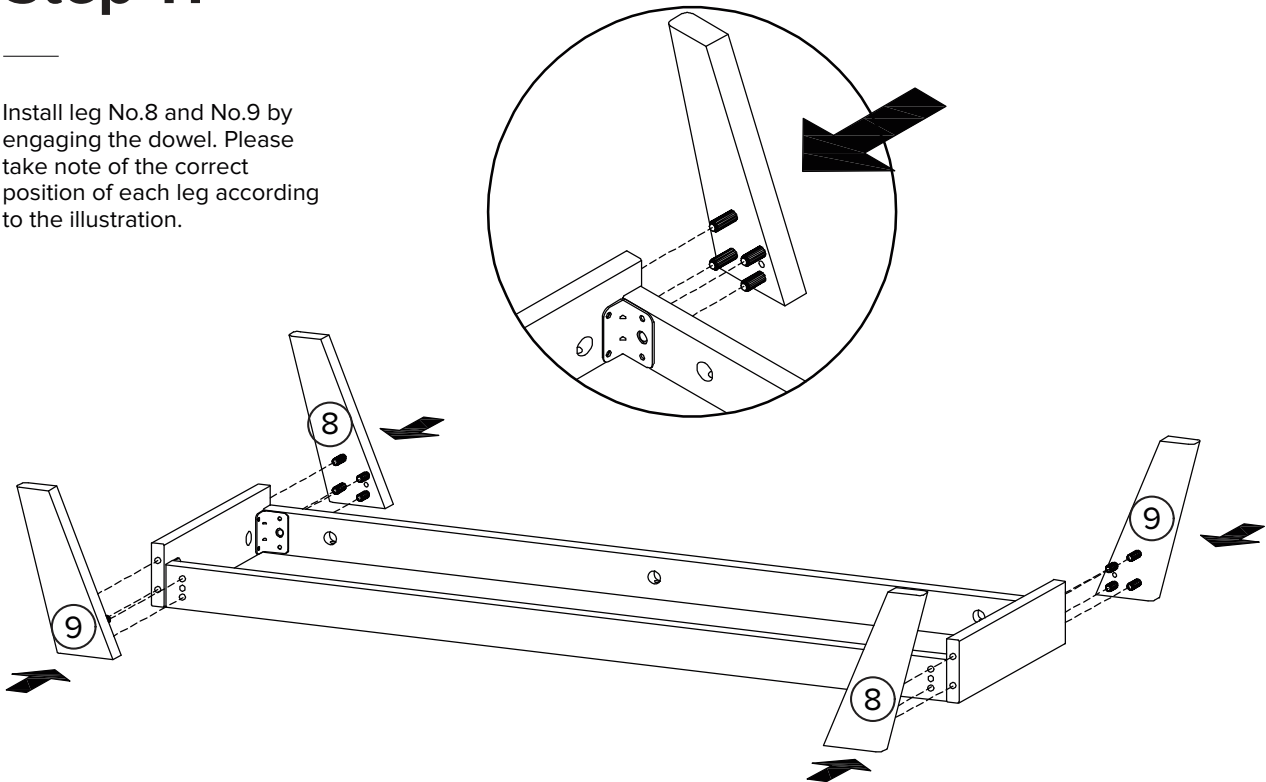

# Step 12

You may require an extra pair of hands to complete this step.

Flip the leg frame carefully and let it stand on the floor. Plug in dowel D to the positions indicated in illustration.

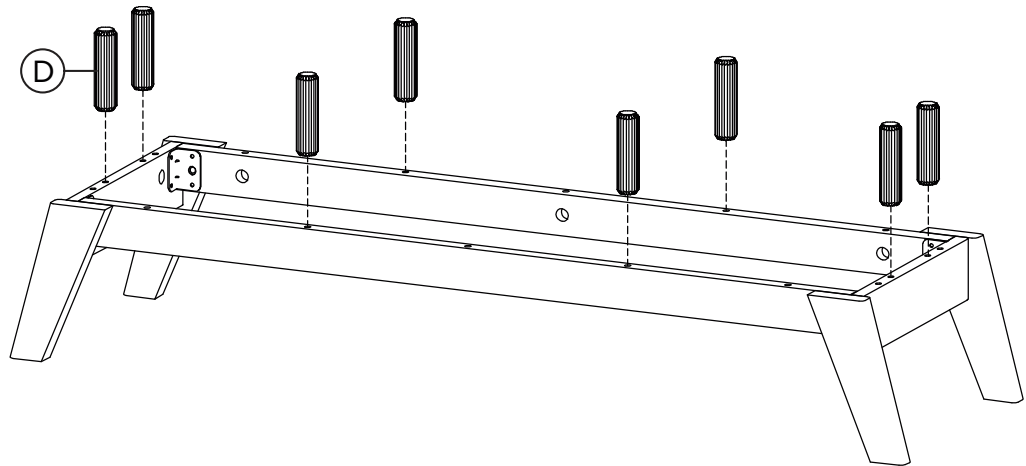

# Step 13

You may require an extra pair of hands to complete this step.

Flip the leg frame around and gently place it on top of the tv stand body previously assembled. Engage the cambolt and dowel previously installed, insert camlock B to indicated locations and then tighten them. Please don't fully tighten the camlock until all cambolts are properly engaged.

Tighten the legs with screw J as illustrated.

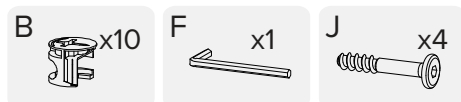
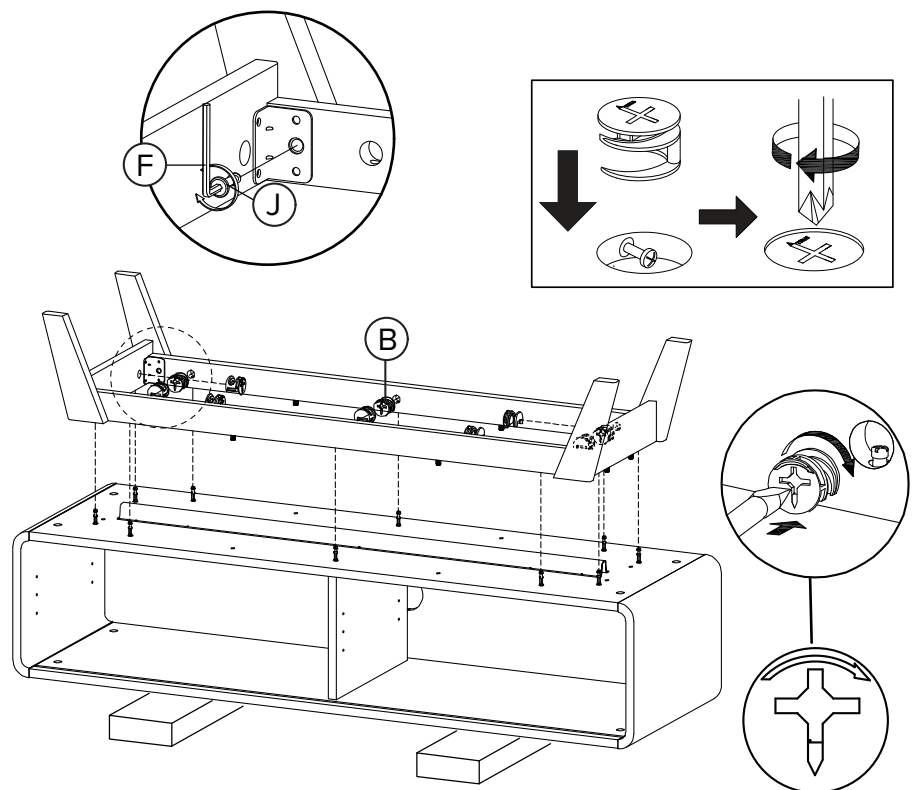

**Missing parts? Or feeling stuck?**  
Chat with us at [www.mopio.com/#chat](http://www.mopio.com/#chat)

**Watch demo video at:**  
<https://bit.ly/33q00RF>

# Step 14

You may require an extra pair of hands to complete this step.

Flip the tv stand carefully and let it stand on its legs. Plug in shelf pin M to the indicated locations.

Take out 2 pieces of shelf board No.5. Identify the front of the shelf board by measuring the distance between the edge and the groove. The front edge to groove measures 8.8" (22.5mm).

Place the shelves gently on top of the shelf pin with front edge facing outside.

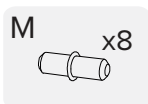
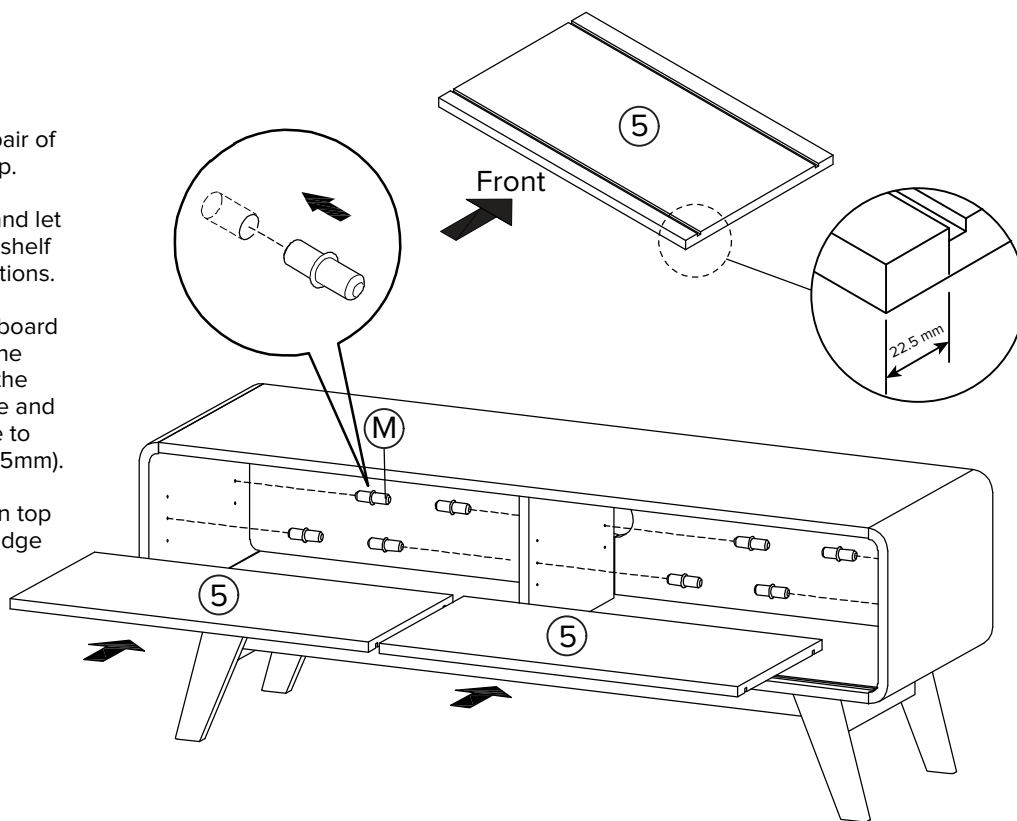

# Step 15

Please check the illustration and identify the correct position of pin sliding. Pin sliding top O has a round shape pin, while pin sliding bottom P has a stripe shape pin.

Insert the pin and ensure pin sliding bottom P's stripe is aligned and parallel with the panel.

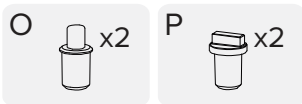
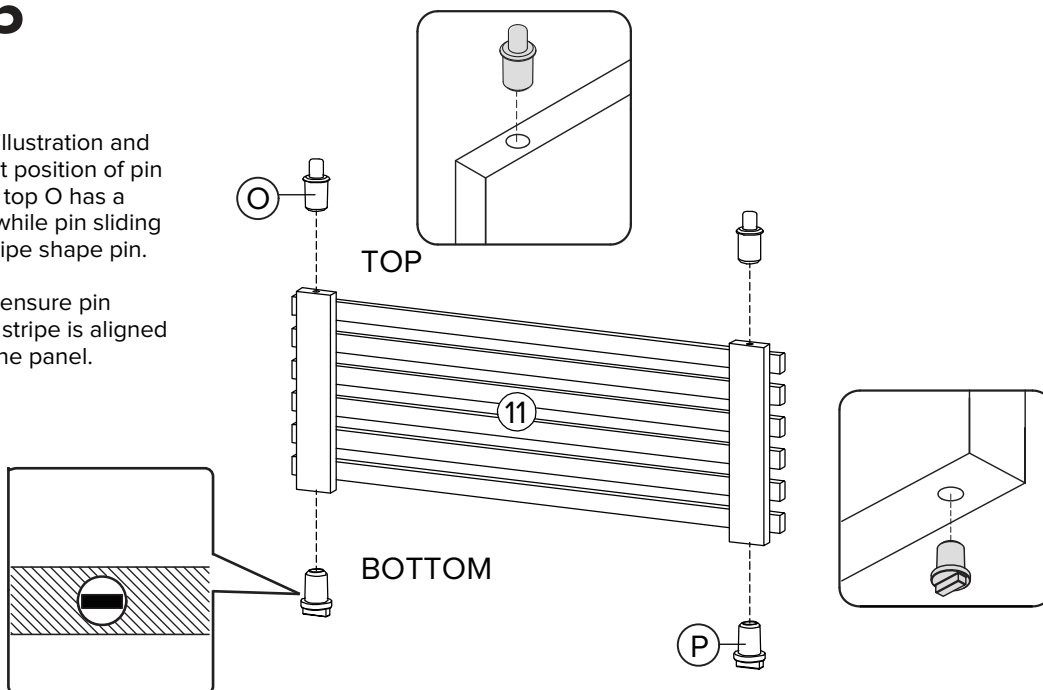

**Missing parts? Or feeling stuck?**  
Chat with us at [www.mopio.com/chat](https://www.mopio.com/chat)

**Watch demo video at:**  
<https://bit.ly/33q00RF>

## Step 16

Insert the door panel's top sliding pin to the groove underneath the top table. While holding its position, insert the bottom sliding pin to the groove at the bottom board. When all pins are in the right position completely, release the door.

Peel buffer sticker N and stick 1 piece to each side of the door panel, at the end of the middle slat.

N x2

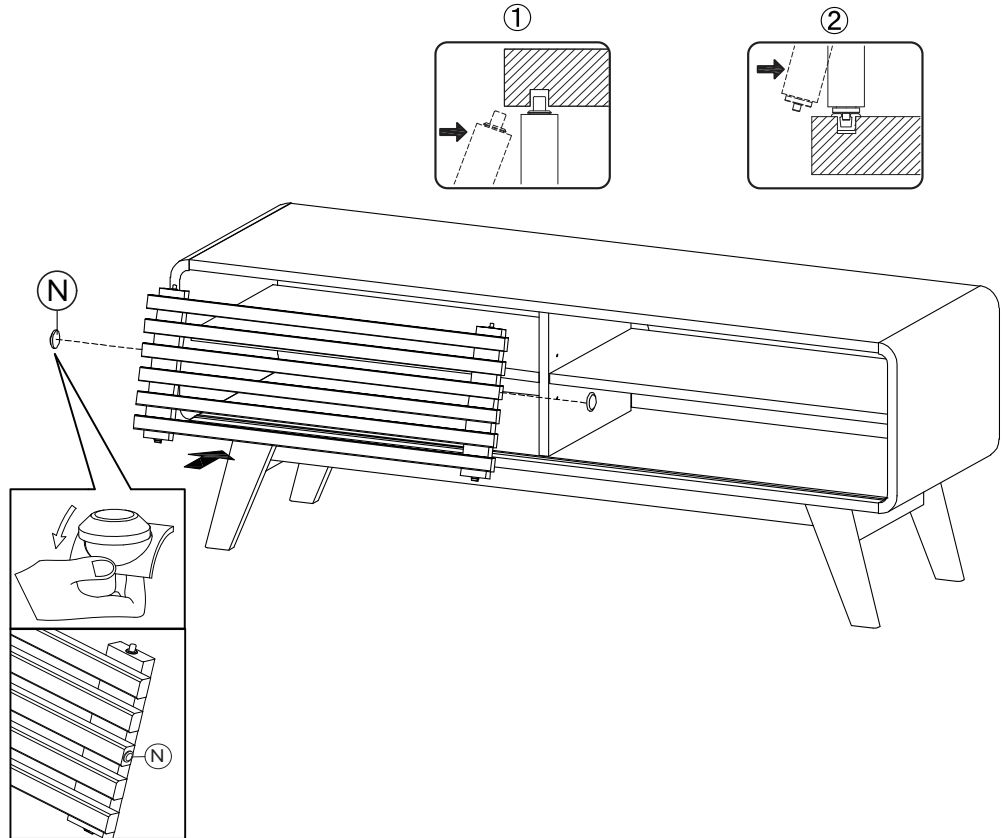

## Finished!

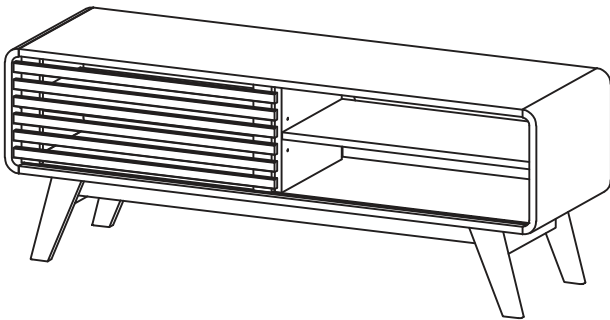

**Congratulations! We're almost there! Please perform following checks to ensure assembly is properly done.**

- Ensure there is no loose camlock or screw.
- Ensure the sliding pin are properly engaged to the groove. Slide the door multiple times to ensure smooth sliding.
- Ensure all legs are fully tightened and not shaky. Ensure floor protectors Q are attached to the leg ends.

**Move your Mopio product carefully, with 2 people lifting it to the preferred location. Clean the product with a dry cloth. You are all set!**

**Enjoy your fresh and updated living space thanks to the addition of your new Mopio product!**



**Missing parts? Or feeling stuck?**  
Chat with us at [www.mopio.com/#chat](https://www.mopio.com/#chat)



**Watch demo video at:**  
<https://bit.ly/33q00RF>

# Care

## Instructions

Your furniture, if treated with respect and love, will last you a long time. Each piece requires light maintenance to maximize its longevity.

### **Few quick tips before using this product:**

1. Recommended weight limit for the tv stand top is 40lbs and 15lbs for each of the shelf compartment.
2. Avoid uneven weight distribution for long time as it may cause damage to the product shape.
3. Sliding door might not slide smoothly when tv stand is overloaded by weight.
4. Check and tighten the camlock and screw periodically as it may loose over the time.

### **How to take care of it?**

1. Avoid direct sunlight or use curtains or blinds to limit the sun exposure to the product.
2. Clean the product regularly with a dry, soft cloth.
3. Avoid using abrasive or liquid cleanser.
4. We recommend always attaching the provided floor protector to the leg ends to protect your floor.
5. Avoid placing hot objects onto the table top surface.
6. Spillage may damage the surface. Clean immediately with a dry cloth.
7. We recommend using placemats or coasters underneath glasses, cups, bowls or plates to prevent scratches to the table surface.

Follow the care instructions and look after your furniture, in return, your furniture will look after you.

We hope to see you soon!



# Frequently Asked Questions

## 1. What should I do if my product received is incomplete?

Mopio products are flat packed and come in separate boxes. Once your order has dispatched and been sent with Fedex, you will receive an email with tracking information. Please note that Fedex may deliver your boxes in separate deliveries. Kindly follow the tracking information, allowing all boxes to be received before starting assembly. If you need further assistance on deliveries tracking, feel free to reach out to us at [www.mopio.com#chat](http://www.mopio.com#chat) or [help@mopio.com](mailto:help@mopio.com).

## 2. What should I do if my shipment is damaged or products received are defective?

We're sorry to hear that! Please email us at [help@mopio.com](mailto:help@mopio.com) or chat with us at [www.mopio.com#chat](http://www.mopio.com#chat) and provide a detailed description of the damage, as well as photos (or videos, where appropriate) showing the damage. We will do our best to resolve the issue as soon as possible.

## 3. Can replacement parts be ordered?

Yes. Simply write to our customer service team at [help@mopio.com](mailto:help@mopio.com) or chat with us at [www.mopio.com#chat](http://www.mopio.com#chat), let us know your order ID and we will be happy to assist further.

## 4. Who do I contact for repair queries?

You may write to us at [help@mopio.com](mailto:help@mopio.com) specifying your queries and we will be able to assist you further.

## 5. What warranty do you offer for your products?

You'll just need to submit your warranty registration upon receiving product at [www.mopio.com/warranty/register](http://www.mopio.com/warranty/register). You may provide your order ID or upload your order confirmation page as your proof of purchase. More details can be found in **Warranty section**.

## 6. How do I claim my warranty?

Easy! Just email us at [help@mopio.com](mailto:help@mopio.com) and provide a detailed description of the fault as well as photos.

## 7. What should I do if I want to return the product?

We offer a 30-day return policy upon product received. To initiate a return request, please contact our customer service team at [help@mopio.com](mailto:help@mopio.com) or [www.mopio.com#chat](http://www.mopio.com#chat) with your reason of returning so we can facilitate the request and assist you further. For more details on the return policy, please refer to **Return section**.

# Warranty & Return

## **1 YEAR LIMITED WARRANTY STATEMENT FOR MANUFACTURING DEFECTS**

Please read this limited warranty carefully. To maintain your warranty, you will need to comply with the conditions stated here. This warranty is for manufacturing defects only and does not cover damages as a result of misuse.

1. Please be sure to register your product at [www.mopio.com/warranty/register](http://www.mopio.com/warranty/register) to receive up to date warranty and product information.
2. Your new product comes with 1-year warranty against manufacturing defects. The warranty starts on the date of purchase. No warranty will be honoured without an original sales receipt. The warranty and financial responsibility of the manufacturer only applies to the products itself.
3. Manufacturing defects include circumstances where the product has broken under normal use and no longer provides proper support. In the event you encounter a manufacturing defect, please stop using this product immediately and contact customer service.
4. This warranty applies only when the product has been properly used by consumers who purchased the product from authorized channels as a new product. Proper use means using the product on a level surface where all legs touch the floor with an equal distribution of weight. Proper use also means that the product was not abused by the consumer, as defined by the manufacturer. This warranty does not constitute agreement to replace other parts.
5. If the product fails due to manufacturing defects, the manufacturer will repair or replace at its discretion and reserves the right to substitute comparable materials or models and does not guarantee that the replacement part will match existing pieces.
6. In the event the product needs to be inspected by the manufacturer to determine a warranty claim, the transportation cost or removal cost is borne by the consumer.

## **MOPIO'S 30-DAY RETURN POLICY**

We believe you will be thrilled with your purchase from Mopio. That's because we go out of our way to ensure that products are designed and built to be just what you need. We understand, however, that sometimes a product may not be what you expected it to be. In that event, we invite you to review the following terms related to returning a product.

## The Return

Returns are to be made within 30 days of the date you received the product. To initiate return request, please message us or contact our customer service team at [help@mopio.com](mailto:help@mopio.com) or [www.mopio.com#chat](https://www.mopio.com#chat) with your reason of returning so we can facilitate the request and issue return authorization to you. Please note the policy is subject to the conditions below:

1. Only undamaged items in original packaging will be accepted under the Returns Policy. Any items that are not returned to us in the original packaging and/or in original condition will incur an additional handling fee (deducted from your refund). It is your responsibility to package the item sufficiently to avoid damage in transit back to us. We encourage customers to photograph the items scheduled for return and the condition of the packaging before handing over to the delivery company.
2. We will not refund a product that you have bought and received where, in our reasonable opinion, the product has: become of unacceptable quality due to fair wear and tear; misuse; using it in an abnormal way; or failure to take reasonable care.
3. We will not be able to offer standard return policy after 30-day timeframe has passed. However, our customer service team is always an email away if you require further assistance with your Mopio products.

## The Refund

We will assist you to complete the return process. We will perform standard inspection upon your return is received and will send you a message to acknowledge the return if item is presenting in original condition with original packaging.

You will be refunded the full amount less return shipping cost. Please note that while shipping charges on original deliveries are subsidized, on returns the full shipping amount paid by Mopio to the delivery partner will be deducted from your refund. **All refunds will take 2 business days to process upon return acknowledgement from us, however actual fund reversal date will depend on your card company's own processing schedule.**

Kindly note, in the event of returning a defective or damaged item, **we will however absorb the shipping charges and ensure your return/exchange experience is hassle free.**

## The Exchange

We put quality as one of our top priorities – we work with experienced manufacturers and have every piece of Mopio product going through strict quality control process. We want to make sure your Mopio product reaches you safe and sound, however we are happy to do an exchange in case you receive a defective or damaged product due to any unforeseen hiccups throughout the journey. Please message us or email us at [help@mopio.com](mailto:help@mopio.com) with proof of defect or damage, our customer service will evaluate the exchange request, and assist you throughout the process accordingly.