

# BROOKLYN 57" TV STAND

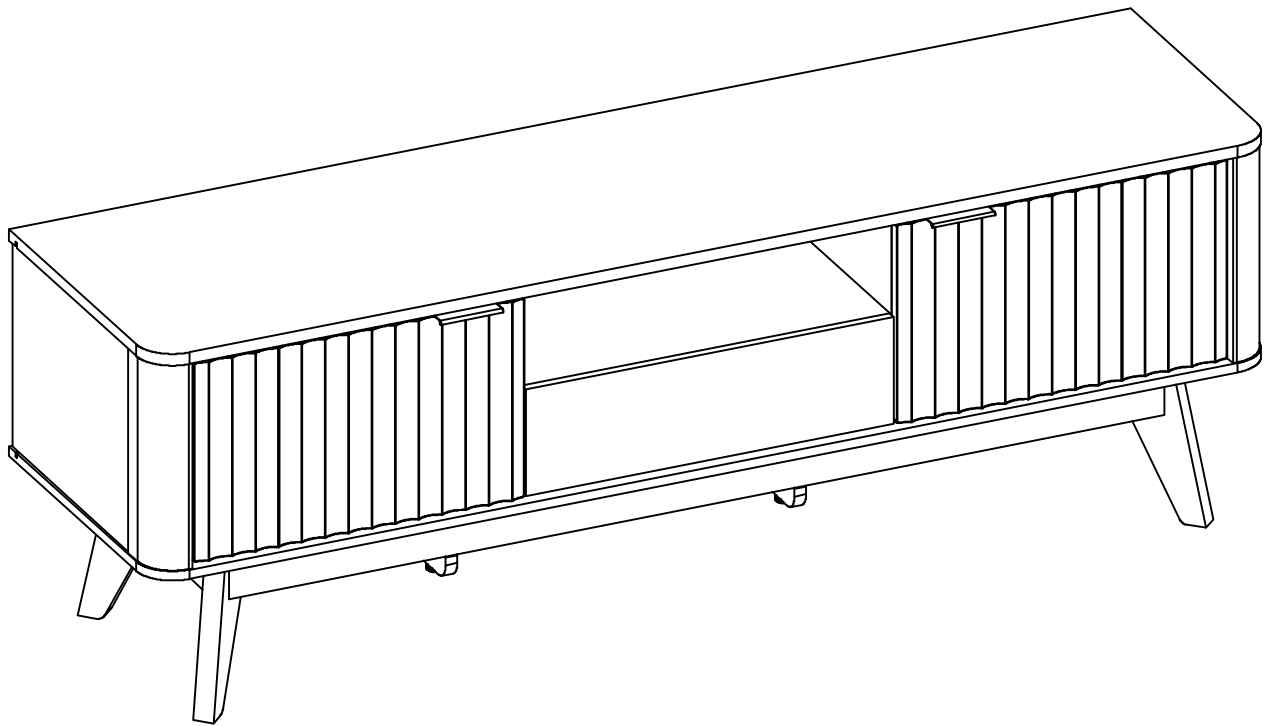

ASSEMBLY INSTRUCTIONS

**mopio**<sup>®</sup>

# Join Mopio Club and enjoy your 1-Year Warranty

We've got more for you. Be part of **Mopio Club** and enjoy:

- Privileged Customer Care
- 10% Off Your Next Purchase (no min spend)
- 1-Year Free Warranty
- Early Access To Upcoming Launches

Scan the QR code or go to the link to find out more:  
[www.mopio.com/club](http://www.mopio.com/club)



## Chat With Us!

For any enquiries or issues regarding your purchase, chat with us at [www.mopio.com/chat](http://www.mopio.com/chat).

Or connect with us through other channels:

✉ [help@mopio.com](mailto:help@mopio.com)

📘 @mopioinc

🌐 [www.mopio.com](http://www.mopio.com)

# Before you start...

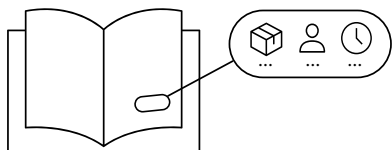

Ensure you have received all cartons and familiarize yourself with the workload. Make sure there are enough helping hands to assist you, and that you have allocated the time required to assemble your new product.

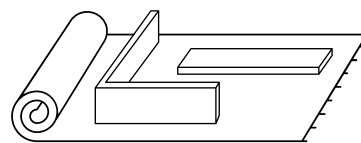

Make sure you have cleared enough space in your home for the assembly. We recommend protecting your floor with a mat or cardboard to avoid scratches during the assembly process.

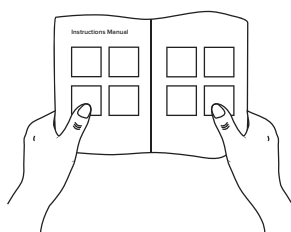

Read instructions carefully and check no parts are missing.

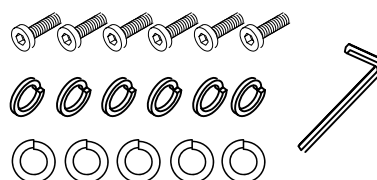

Lay out all hardware on a soft surface so you can easily identify them.

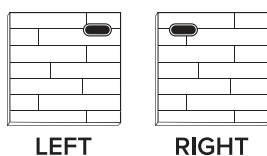

Carefully identify all components in order to differentiate which pieces are left and right.

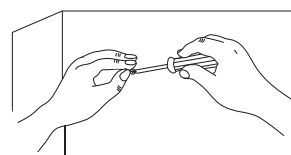

Install your new product carefully following the instructions. Don't skip ahead!

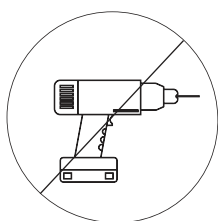

**DO NOT** over tighten screws or use a drill. It will damage the product.



If you need further assistance with assembling your Mopio product, please chat with us at [www.mopio.com#chat](https://www.mopio.com#chat).

# Parts



Watch installation demo video at:  
<https://bit.ly/3syt2Lk>



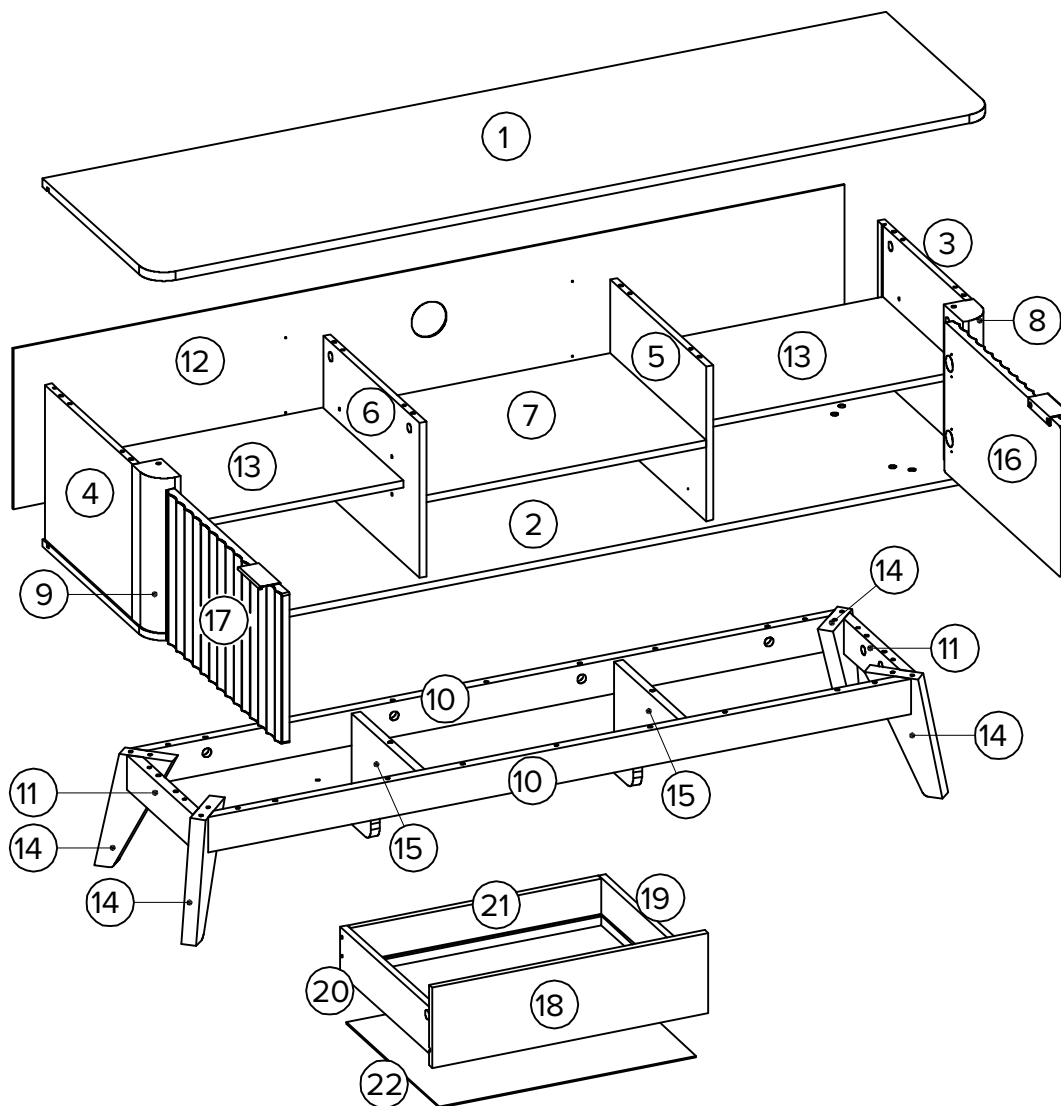







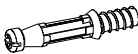
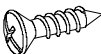
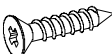

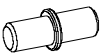

- |        |        |        |        |
|--------|--------|--------|--------|
| □ ① x1 | □ ⑦ x1 | □ ⑬ x2 | □ ⑲ x1 |
| □ ② x1 | □ ⑧ x1 | □ ⑭ x4 | □ ⑳ x1 |
| □ ③ x1 | □ ⑨ x1 | □ ⑮ x2 | □ ㉑ x1 |
| □ ④ x1 | □ ⑩ x2 | □ ⑯ x1 | □ ㉒ x1 |
| □ ⑤ x1 | □ ⑪ x2 | □ ⑰ x1 |        |
| □ ⑥ x1 | □ ⑫ x1 | □ ⑱ x1 |        |

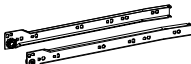
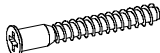

# Hardware

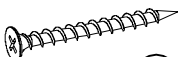

Watch installation demo video at:  
<https://bit.ly/3syt2Lk>

- |                          |   |                        |                          |   |                      |                          |   |                        |
|--------------------------|---|------------------------|--------------------------|---|----------------------|--------------------------|---|------------------------|
| <input type="checkbox"/> |    | Cambolt<br>Ø 6 x 35 mm | <input type="checkbox"/> |    | Screw<br>Ø 7 x 14 mm | <input type="checkbox"/> |    | Screw<br>Ø 6 x 19 mm   |
|                          | (A)   | <b>x36</b>             |                          | (H)   | <b>x8</b>            |                          | (O)   | <b>x12</b>             |
| <input type="checkbox"/> |    | Camlock<br>Ø 15 mm     | <input type="checkbox"/> |    | Shelf Pin            | <input type="checkbox"/> |    | Adjustable<br>leveller |
|                          | (B)   | <b>x36</b>             |                          | (I)   | <b>x8</b>            |                          | (P)   | <b>x2</b>              |
| <input type="checkbox"/> |    | Sticker<br>Ø 25 mm     | <input type="checkbox"/> |    | Handle<br>80 mm      | <input type="checkbox"/> |    | Barrel<br>nut          |
|                          | (C)   | <b>x24</b>             |                          | (J)   | <b>x2</b>            |                          | (Q)   | <b>x2</b>              |
| <input type="checkbox"/> |    | Dowel<br>Ø 6 x 30 mm   | <input type="checkbox"/> |    | Screw<br>Ø 6 x 12 mm | <input type="checkbox"/> |    | Drawer<br>runner A     |
|                          | (D)   | <b>x44</b>             |                          | (K)   | <b>x4</b>            |                          | (R)   | <b>x1</b>              |
| <input type="checkbox"/> |  | Assembly<br>screw      | <input type="checkbox"/> |  | Screw<br>Ø 6 x 9 mm  | <input type="checkbox"/> |  | Drawer<br>runner B     |
|                          | (E)   | <b>x8</b>              |                          | (L)   | <b>x10</b>           |                          | (S)   | <b>x1</b>              |
| <input type="checkbox"/> |  | Screw<br>Ø 6 x 52 mm   | <input type="checkbox"/> |  | Screw<br>Ø 4 x 13 mm |                          |   |                        |
|                          | (F)   | <b>x14</b>             |                          | (M)   | <b>x4</b>            |                          |   |                        |
| <input type="checkbox"/> |  | Hinge                  | <input type="checkbox"/> |  | Wedge                |                          |   |                        |
|                          | (G)   | <b>x4</b>              |                          | (N)   | <b>x12</b>           |                          |   |                        |



This product will require 2hrs for assembly. We hope that you will enjoy the assembly process and hang in there!



There are inner box(es) that include components required to complete this assembly.



Please do not completely tighten all the hardware, until the entire assembly is complete.



Before discarding the packaging, please use the checklist to ensure that you have all the parts required to assemble your product. Please kindly note you will need the original package if you want to return the product later.



If parts are missing or damaged, we will gladly ship your replacements parts free of charge. Please contact us at [help@mopio.com](mailto:help@mopio.com) or chat with us at [www.mopio.com#chat](https://www.mopio.com#chat).



**x1**



**x2**



**2 hours**

# Step 1

Ensure your floor is properly protected, then take out panel (5), (6), and (7).

Screw Cambolt (A) to panel (5) and (6) (don't over screw).

Plug in Dowel (D) into the center holes on the side of each panel (5), (6), and (7).

Fasten Right Drawer Runner A (R) onto Panel (5) with Screw (L).

Fasten Left Drawer Runner A (R) onto Panel (6) with Screw (L).

\*Don't screw too deep

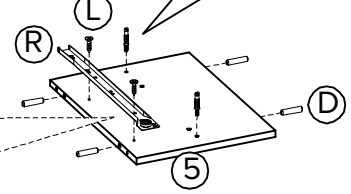
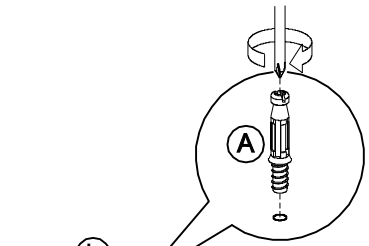
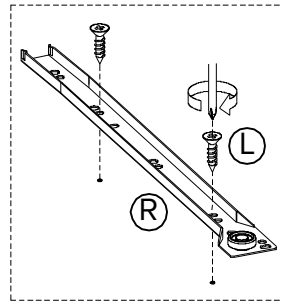
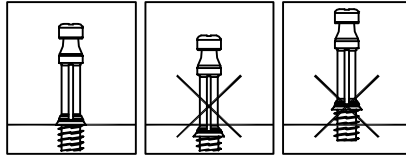

SECTION A

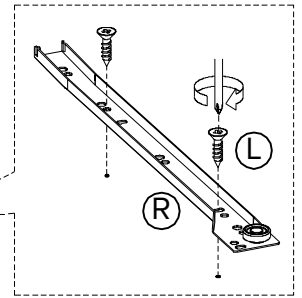

SECTION B

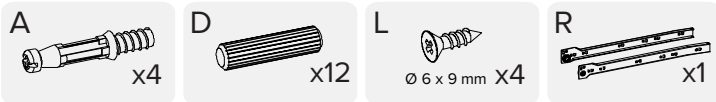
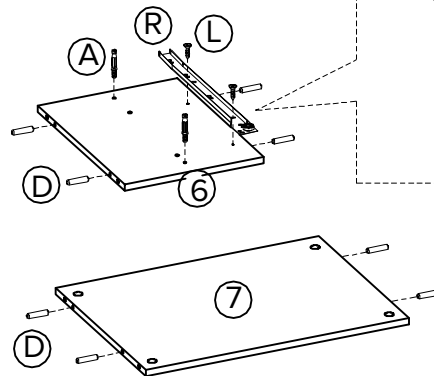
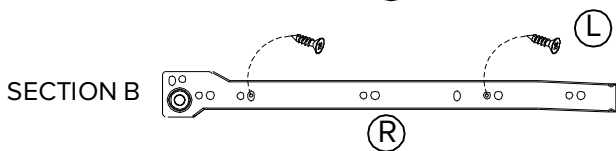
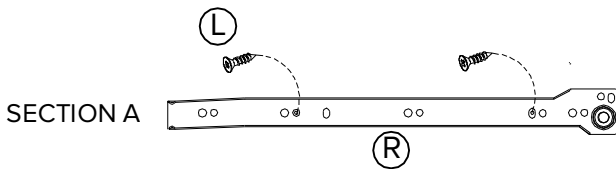

# Step 2

Install panel (5) and (6) onto panel (7) by inserting camlock (B) and tightening it with a screwdriver.

Please ensure the correct camlock placing orientation. Check the illustration carefully.

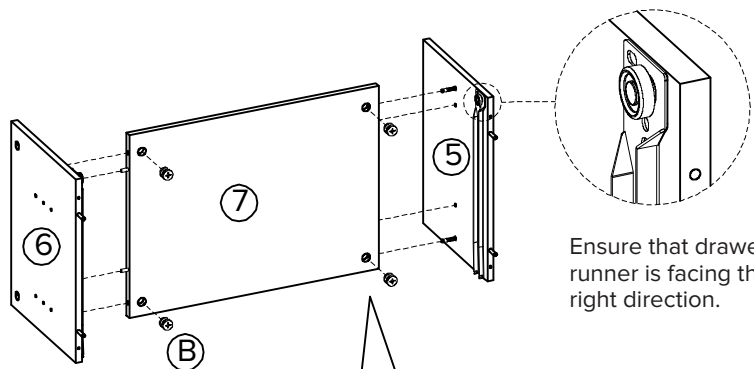

Ensure that drawer runner is facing the right direction.

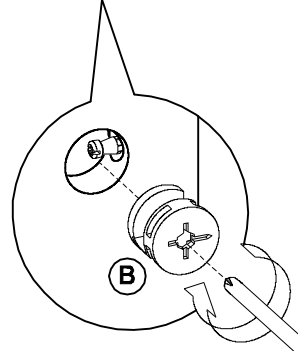
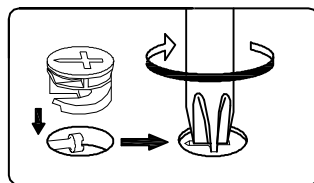

**Missing parts? Or feeling stuck?**  
Chat with us at [www.mopio.com#chat](https://www.mopio.com#chat)

**Watch demo video at:**  
<https://bit.ly/3syt2Lk>

# Step 3

Screw Cambolt (A) to panel (8), and (9) (don't over screw).

Plug in Dowel (D) into the center holes on the each side of panel (3) and (4).

Please ensure your screw or plug into the correct hole according to the illustration.

\*Don't screw too deep

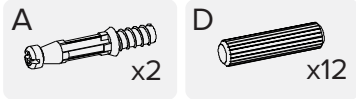
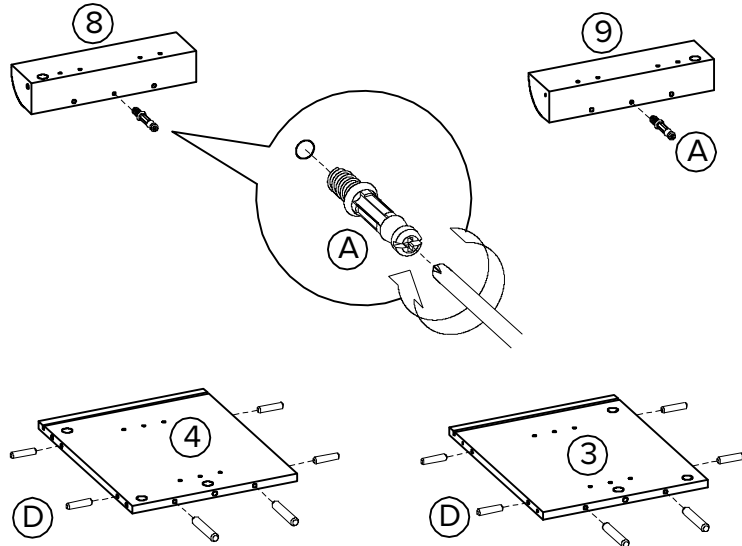
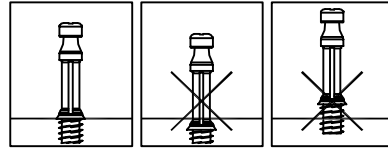

# Step 4

Install panel (4) onto panel (9) by inserting camlock (B) and tightening it with a screwdriver.

Install panel (3) onto panel (8) by inserting camlock (B) and tightening it with a screwdriver.

Please ensure the correct camlock placing orientation. Check the illustration carefully.

Place Sticker Cam (C) over the Connecting Cams (B).

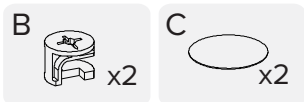
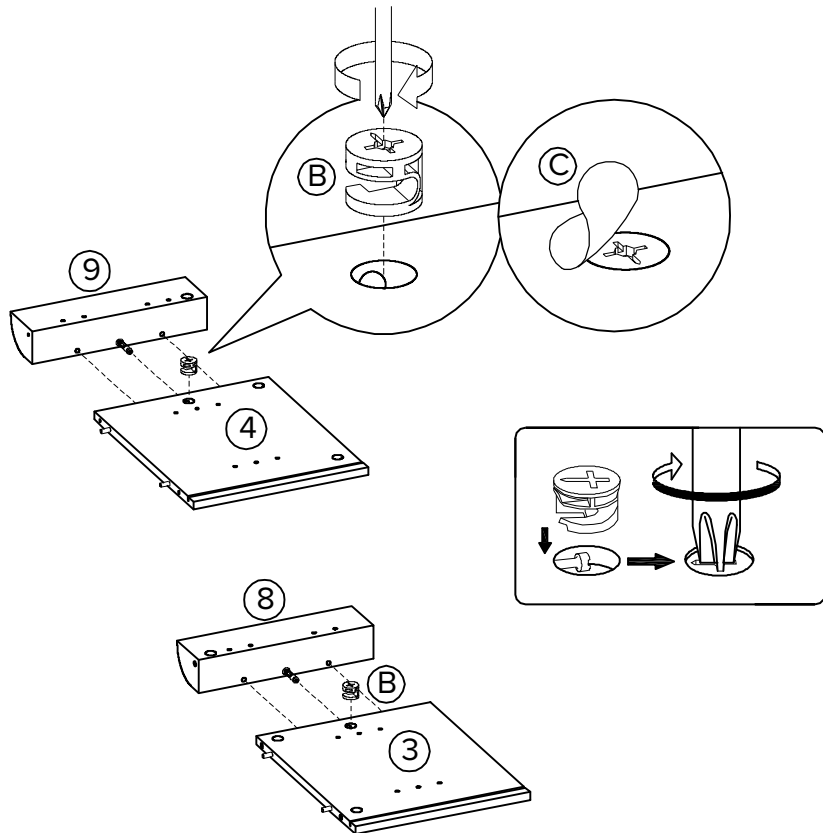

**Missing parts? Or feeling stuck?**  
Chat with us at [www.mopio.com/#chat](https://www.mopio.com/#chat)

**Watch demo video at:**  
<https://bit.ly/3syt2Lk>

# Step 5

Screw Cambolt (A) to panel (2).

Plug in Dowel (D) into the holes of 2 pieces of panel (10).

Please ensure your screw or plug into the correct hole according to the illustration.

\*Don't screw too deep

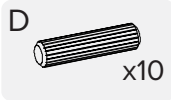
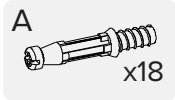
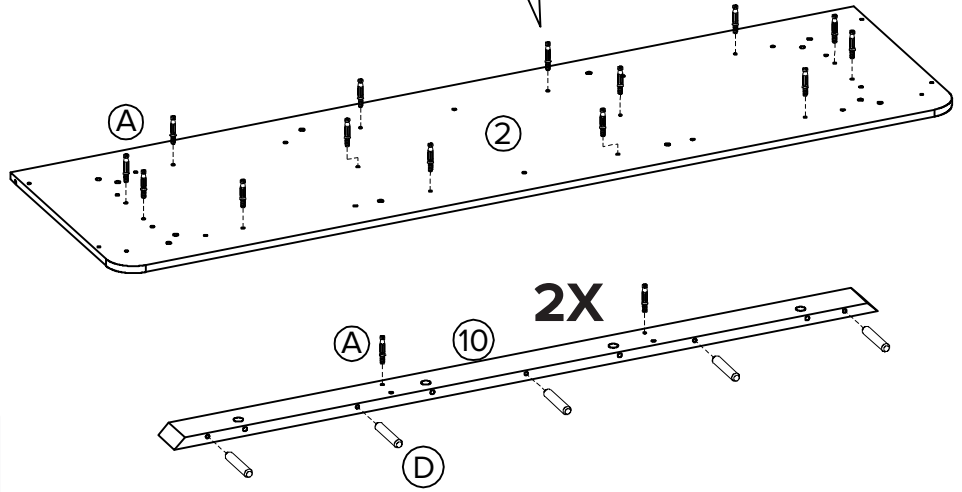
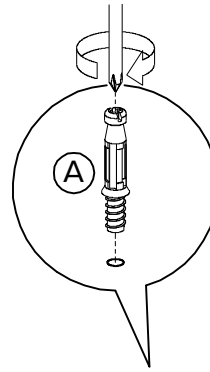
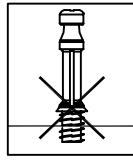
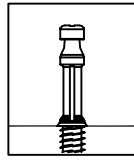

# Step 6

You may require an extra pair of hands to complete this step.

Install Leg (14) onto panel (2) by inserting assembly screw (E) and tightening it with a screwdriver.

Place Sticker Cam (C) over the Assembly screw (E).

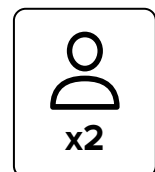
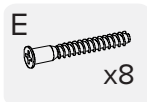
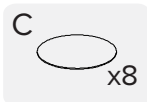
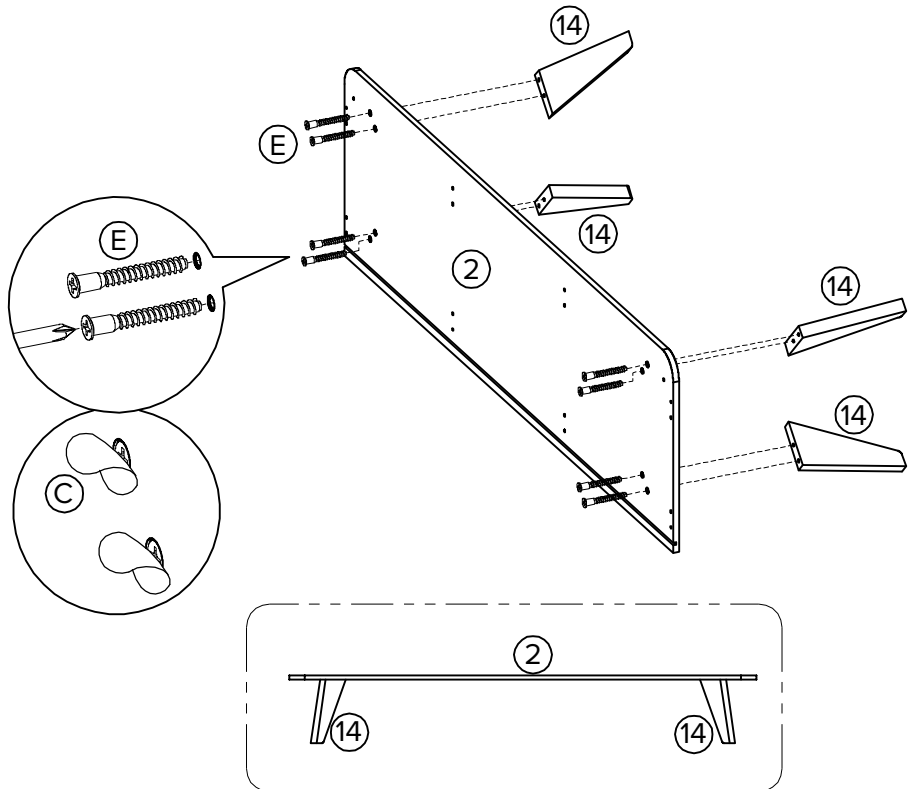

**Missing parts? Or feeling stuck?**  
Chat with us at [www.mopio.com/#chat](https://www.mopio.com/#chat)

**Watch demo video at:**  
<https://bit.ly/3syt2Lk>



# Step 7

Position panel (2), (3), and (4) onto assembled unit by inserting screw (F) and tightening with a screwdriver.

Please ensure you screw or plug into the correct holes according to the illustrations.

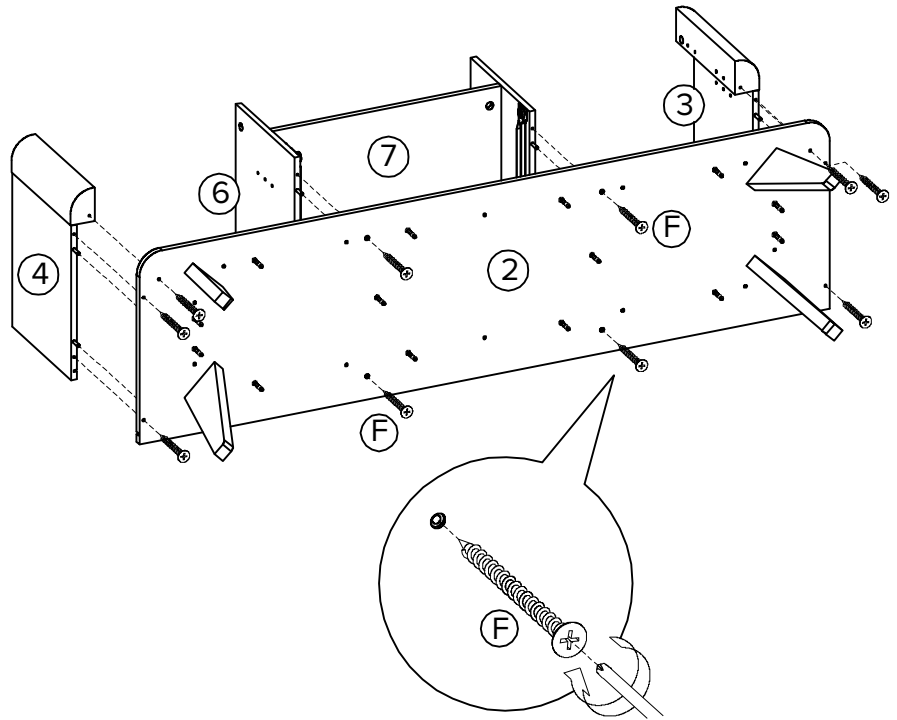

# Step 8

Plug in Dowel (D) into the center holes on the side of 2 pieces of panel (11) and 2 pieces of panel (15).

Insert Barrel Nut (Q) and Adjustable Leveller (P). Please ensure the correct Barrel Nut placing orientation. Check the illustration carefully.

Place Sticker Cam (C) on Barrel Nut (Q).

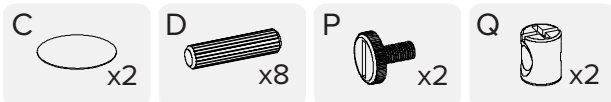
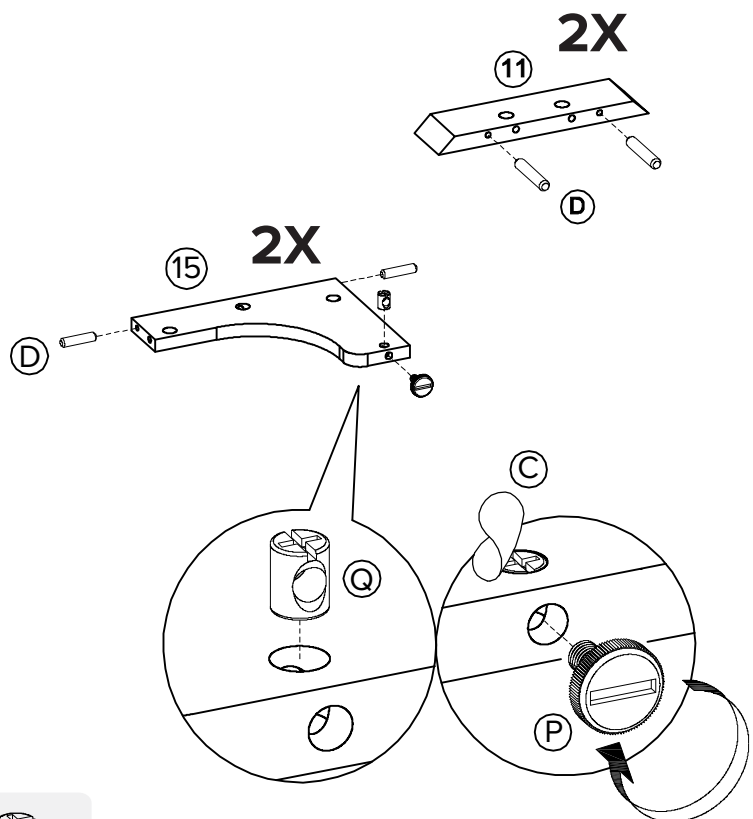

**Missing parts? Or feeling stuck?**  
Chat with us at [www.mopio.com/#chat](https://www.mopio.com/#chat)

**Watch demo video at:**  
<https://bit.ly/3syt2Lk>

## Step 9

Install 2 pieces of panel (10) with 2 pieces of panel (15) by inserting camlock (B) and tightening it with a screwdriver.

Please ensure the correct camlock placing orientation. Check the illustration carefully

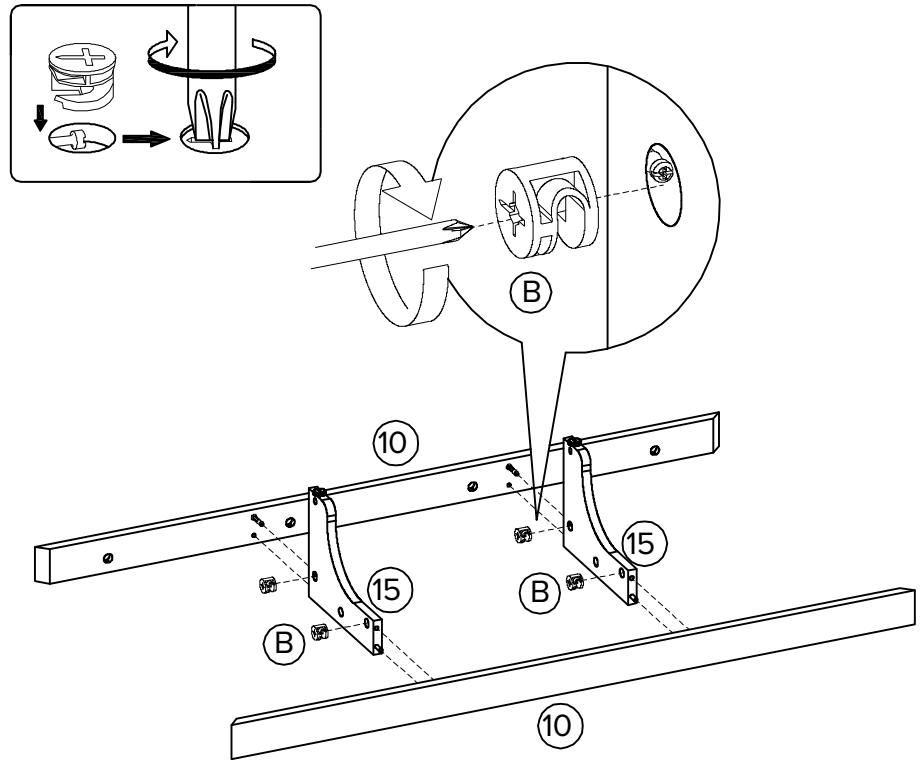

## Step 10

Install assembled unit (10 & 15) onto assembled unit by inserting camlock (B) and tightening it with a screw.

Please ensure you screw or plug into the correct holes according to the illustrations.

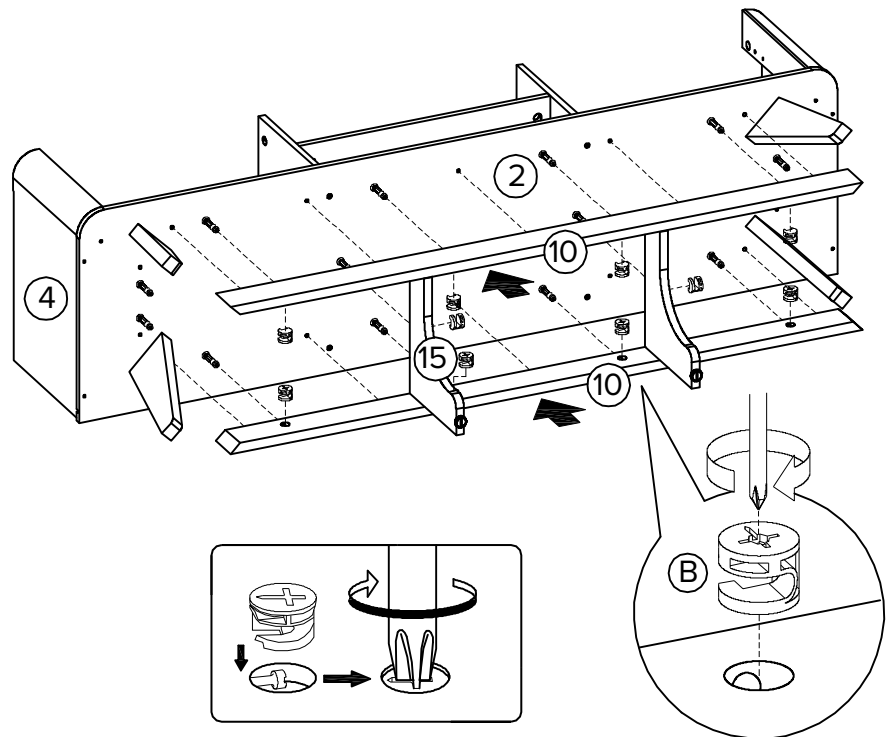

Missing parts? Or feeling stuck?  
Chat with us at [www.mopio.com/#chat](https://www.mopio.com/#chat)



Watch demo video at:  
<https://bit.ly/3syt2Lk>

# Step 11

Position panel (11) onto assembled unit by inserting camlock (B) by tightening with a screw.

Please ensure you screw or plug into the correct holes according to the illustrations.

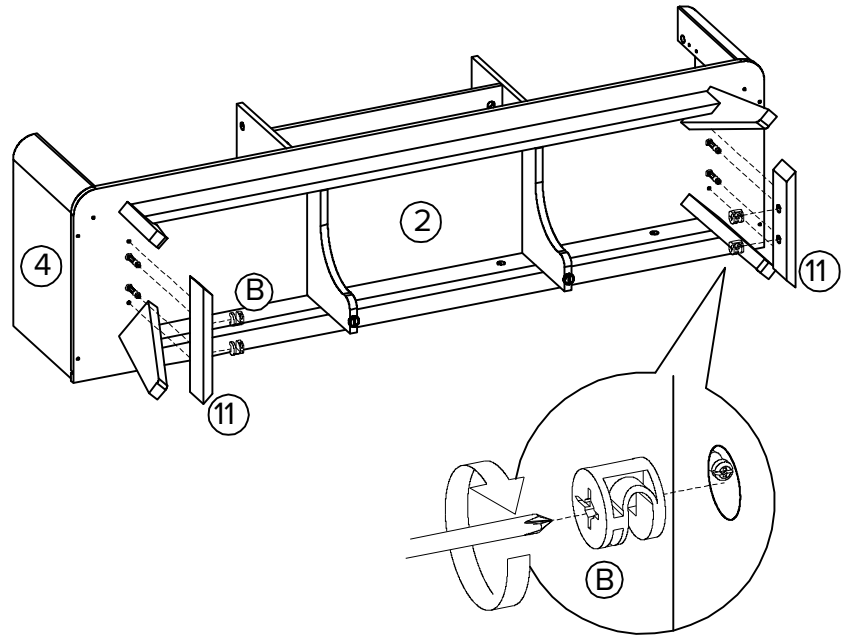

# Step 12

Slide Back Panel (12) into grooves of Assembled Unit as shown.

Adjust the adjustable leveller. Full insert and do not touch the floor.



From this step onwards, always lift when moving the product, do not drag.

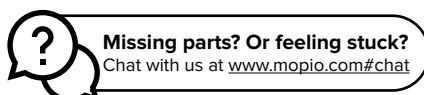
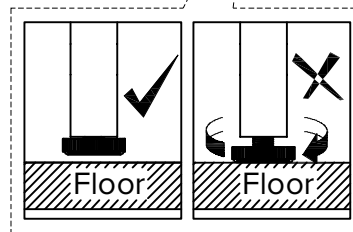
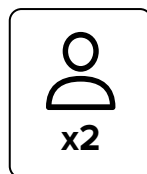
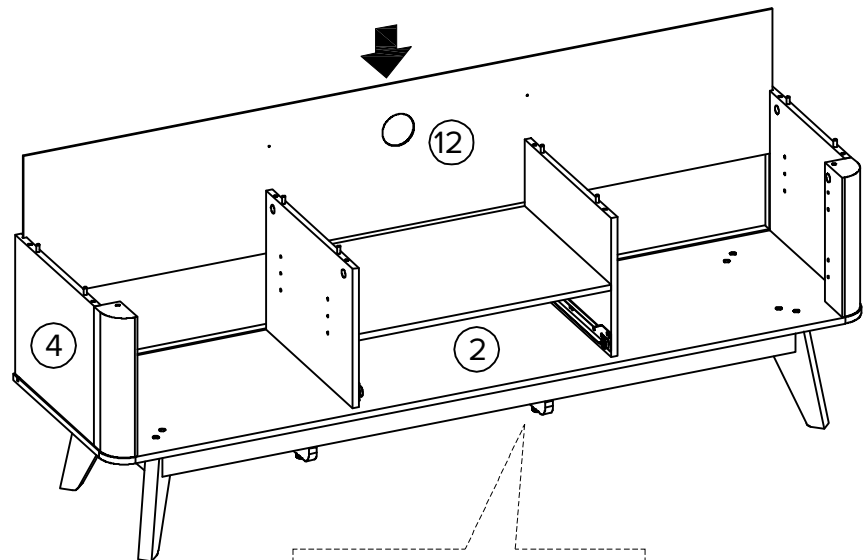

Missing parts? Or feeling stuck?  
Chat with us at [www.mopio.com/#chat](https://www.mopio.com/#chat)



Watch demo video at:  
<https://bit.ly/3syt2Lk>

# Step 13

Screw Cambolt (A) to panel (1).  
(Don't over screw)

Please ensure your screw or  
plug into the correct hole  
according to the illustration.

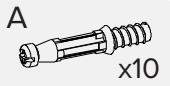
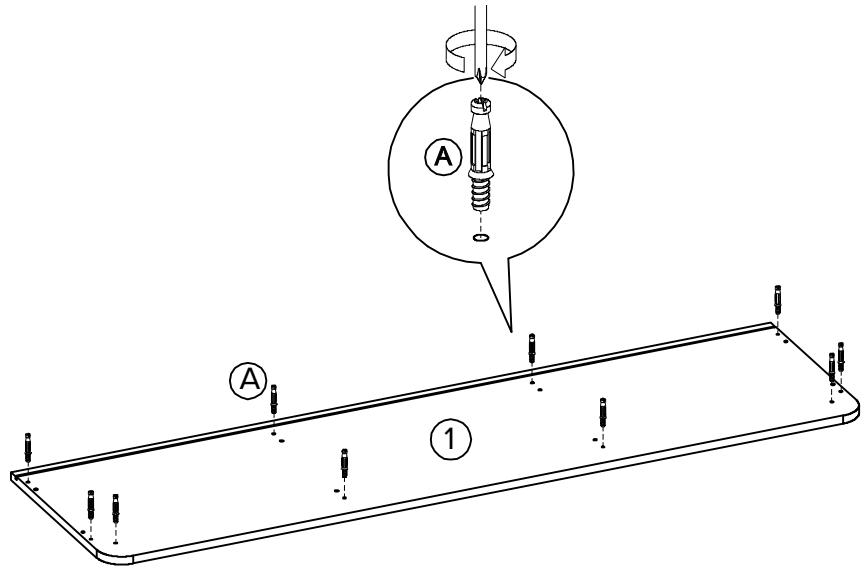

# Step 14

Install panel (1) onto assembled  
unit by inserting camlock (B) and  
tightening it with a screwdriver.

Please ensure the correct camlock  
placing orientation. Check the  
illustration carefully.

Place Sticker Cam (C) over the  
Connecting Cams (B).

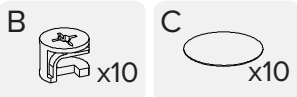
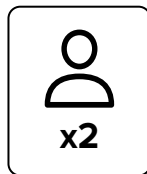
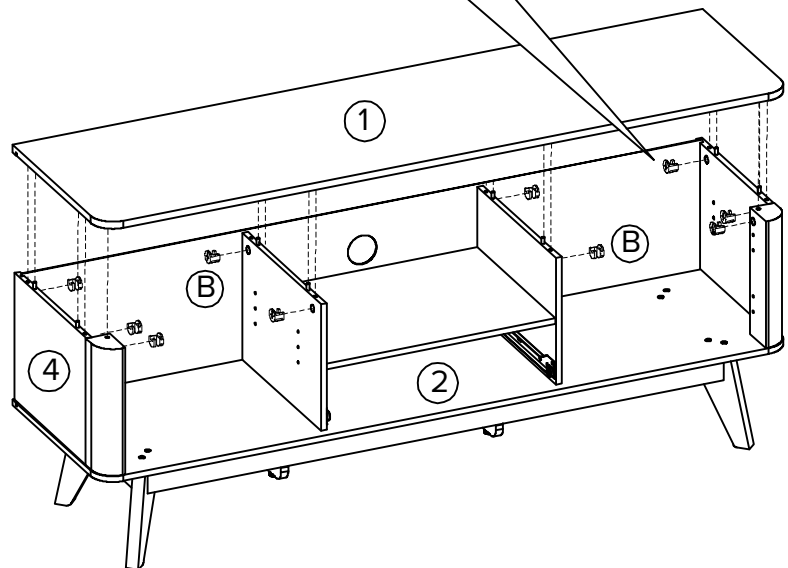
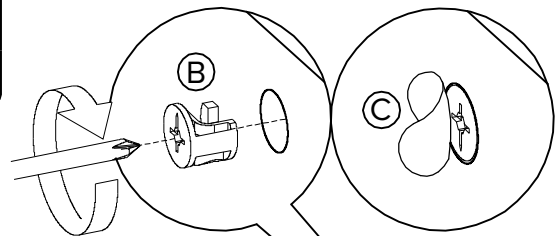
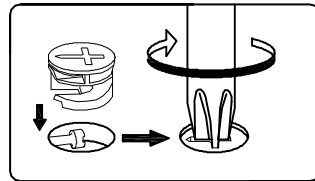

**?** Missing parts? Or feeling stuck?  
Chat with us at [www.mopio.com/#chat](https://www.mopio.com/#chat)

**▶** Watch demo video at:  
<https://bit.ly/3syt2Lk>

# Step 15

Gently adjust Panel (1) sideways in either direction until the diagonal measurements of the frame are equal.

Holding the assembly in place, fix the Wedge (N) with Screws (O) & (M) as shown.

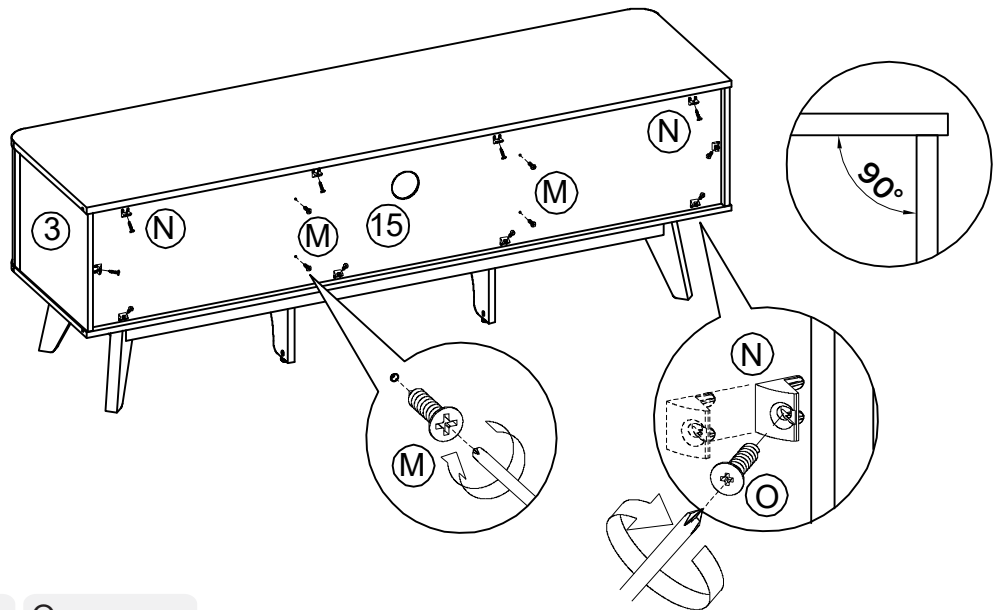

# Step 16

Prepare Panel (18), (19) and (20).

Screw Cambolt (A) to panel (18).

Plug in Dowel (D) into the center holes on the side of panel (19) and (20).

Please ensure your screw or plug into the correct hole according to the illustration.

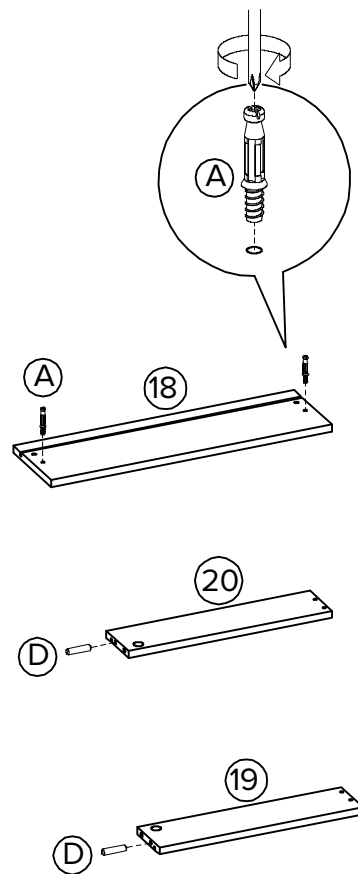

**Missing parts? Or feeling stuck?**  
Chat with us at [www.mopio.com/#chat](https://www.mopio.com/#chat)

**Watch demo video at:**  
<https://bit.ly/3syt2Lk>

# Step 17

Install panel (19) and (20) onto panel (18) by inserting camlock (B) and tightening it with a screwdriver. Place Sticker Cam (C) over the Connecting Cams (B).

Slide panel (22) into grooves of Drawer Side panels as shown.

Install panel (21) onto the assembled unit by inserting screw (F) and tightening it with a screw driver.

Please ensure the correct camlock placing orientation. Check the illustration carefully.

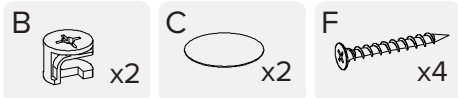
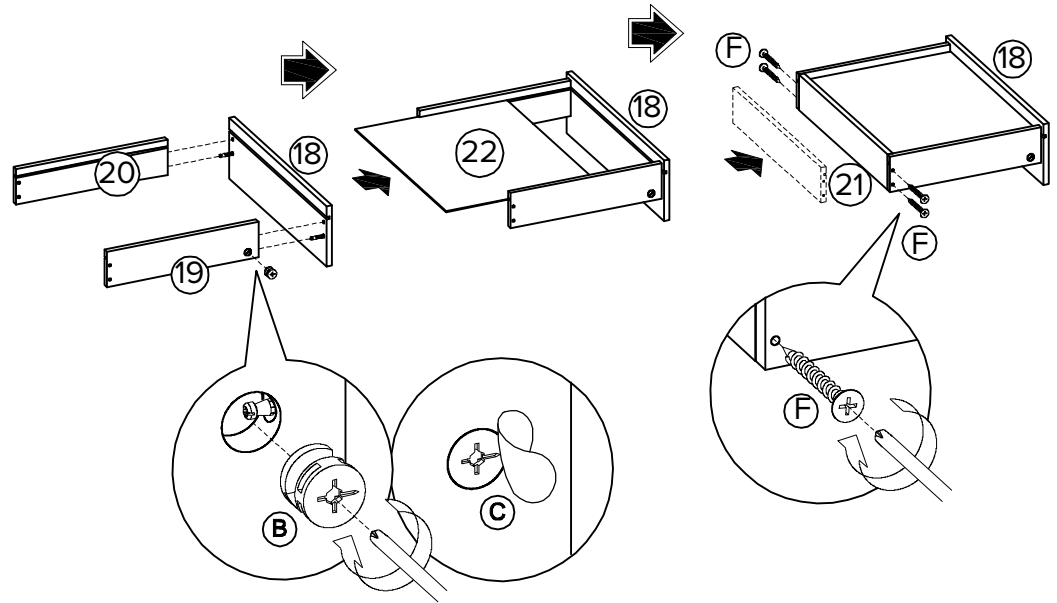

# Step 18

Adjust the drawer assembly so that the diagonal measurements of the drawer are equal.

Insert Wedge (N) between the drawer panels as shown and fasten them with Screws (O).

Fasten 1 set Drawer Runners B (S) onto drawer with Screws (L).

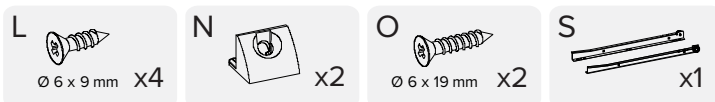
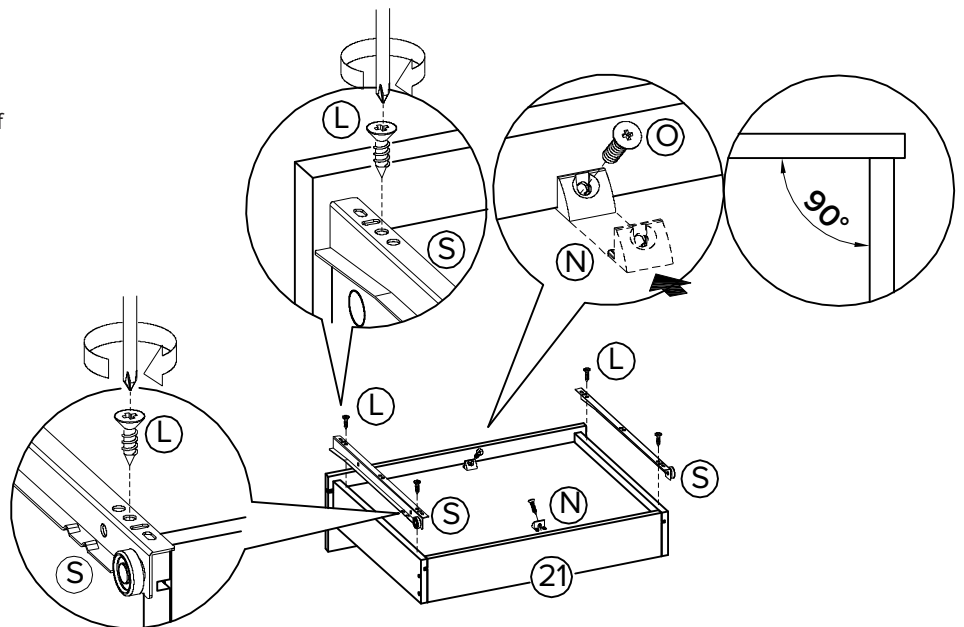

**Missing parts? Or feeling stuck?**  
 Chat with us at [www.mopio.com#chat](http://www.mopio.com#chat)

**Watch demo video at:**  
<https://bit.ly/3syt2Lk>

# Step 19

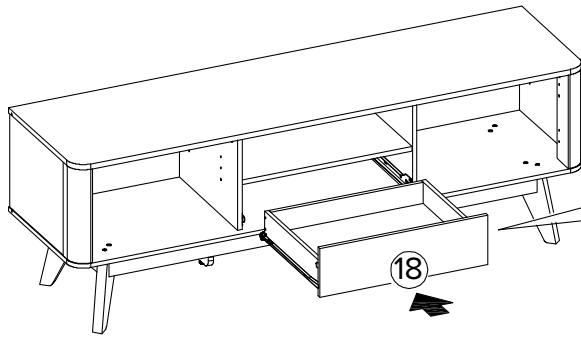

Insert Drawer into the TV Stand as shown.

**Detail 1:**

In the event of misaligned Drawer or Drawer hit the bottom panel. To adjust gaps around the Drawer, first remove the Drawer. Loosen screws (L) on the runners and adjust Drawer Runners (R) to the up or down direction.

**Detail 2:**

When the drawer front (18) are correctly aligned, re-tighten screws (L) on the runners (R). Lock the runners (R) in place by fastening additional Screw (L) to each runner (R) as shown.

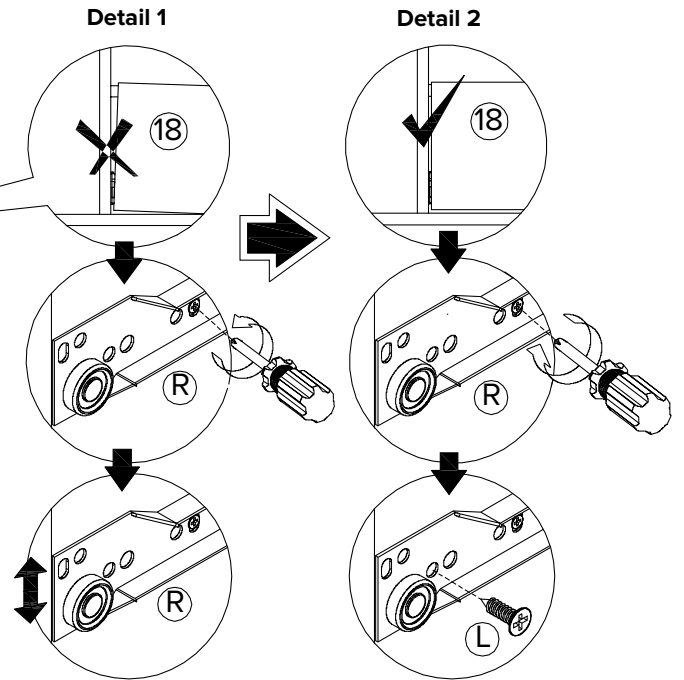

# Step 20

Fasten Hinges (G) with Screws (H) onto door panel (16) & (17).

Fasten handle (J) with Screws (K) onto door panel (16) & (17).

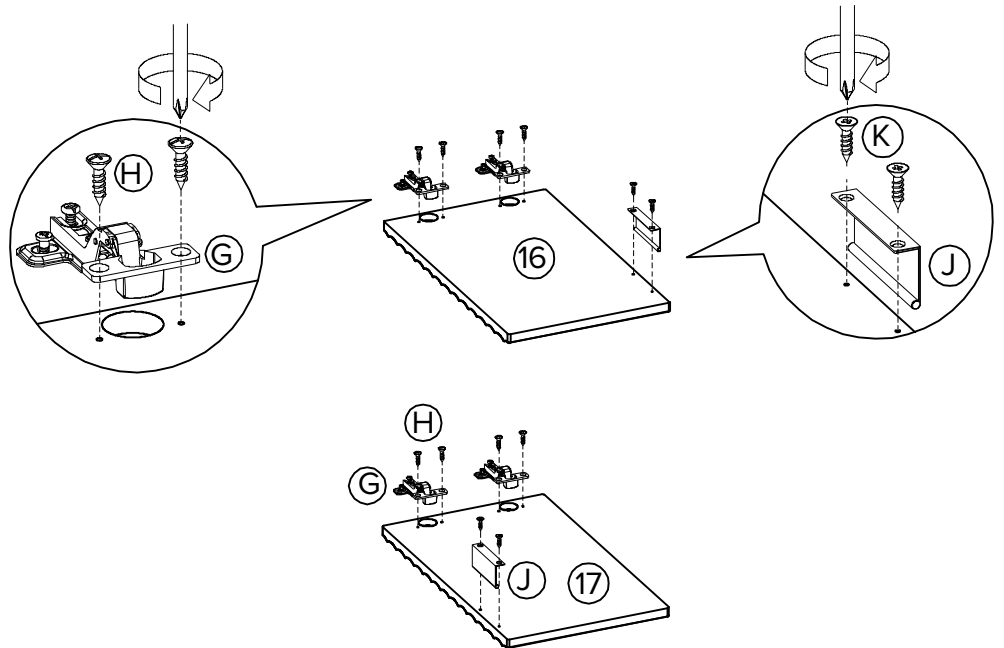

**Missing parts? Or feeling stuck?**  
Chat with us at [www.mopio.com/#chat](https://www.mopio.com/#chat)

**Watch demo video at:**  
<https://bit.ly/3syt2Lk>

# Step 21

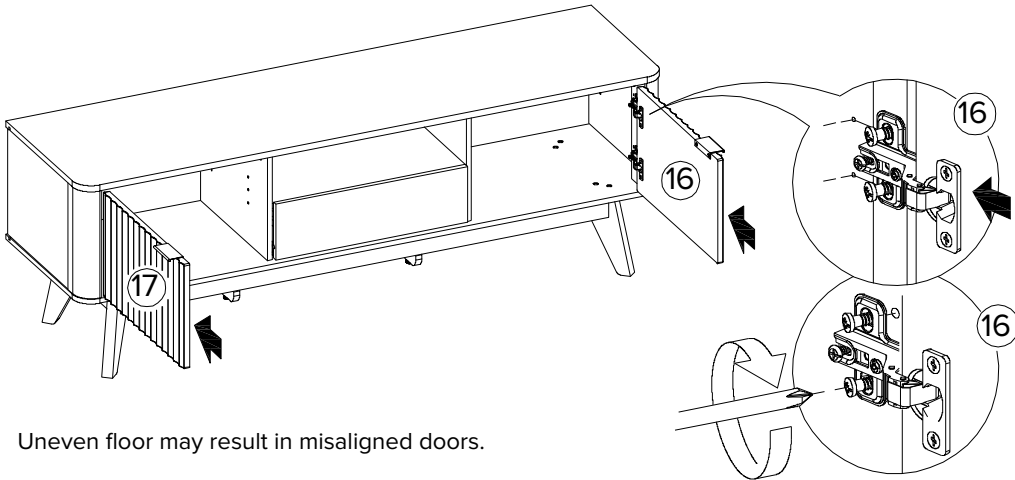

Uneven floor may result in misaligned doors.

Insert drawers into the TV Stand as shown.

Insert door hinges on door panel (16) onto right side panel with a screwdriver.

Insert door hinges on door panel (17) onto left side panel with a screwdriver.

Adjust the alignment of the doors if necessary.

# Step 22

**To adjust the door to the front and back direction**, loosen the back screw as shown on the illustration. Adjust the door to the front or back direction and re-tighten the screw.

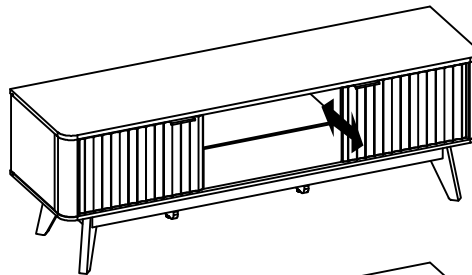

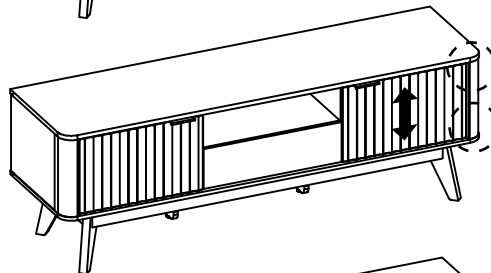

**To adjust the door to the up and down direction**, loosen 2 screws on mounting plate as shown on the illustration. You may need to loosen 2 hinges at the same time to perform this adjustment. Adjust the door to the up and down direction and re-tighten the screw.

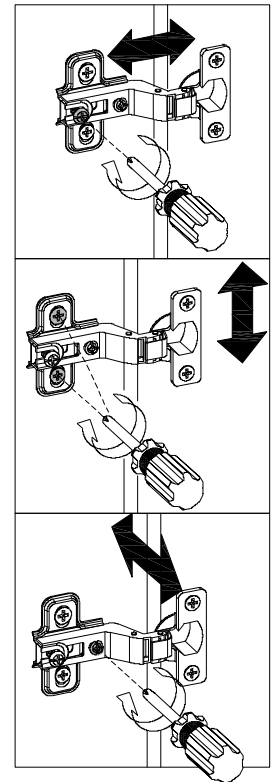
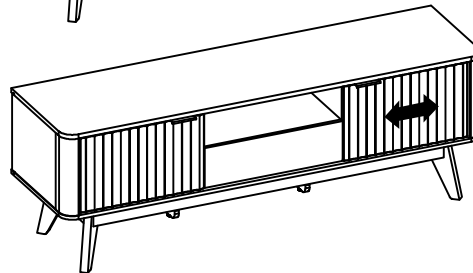

**To adjust the door to the side direction**, simply loosen or tighten the front screw as shown on the illustration.



 **Missing parts? Or feeling stuck?**  
Chat with us at [www.mopio.com/#chat](https://www.mopio.com/#chat)

 **Watch demo video at:**  
<https://bit.ly/3syt2Lk>



## Step 23

Insert Shelf Pins (I) onto Side and Divider Panels in the desired positions.

Slide Shelves (13) diagonally in and rest on the Shelf Pins (I).

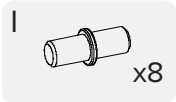
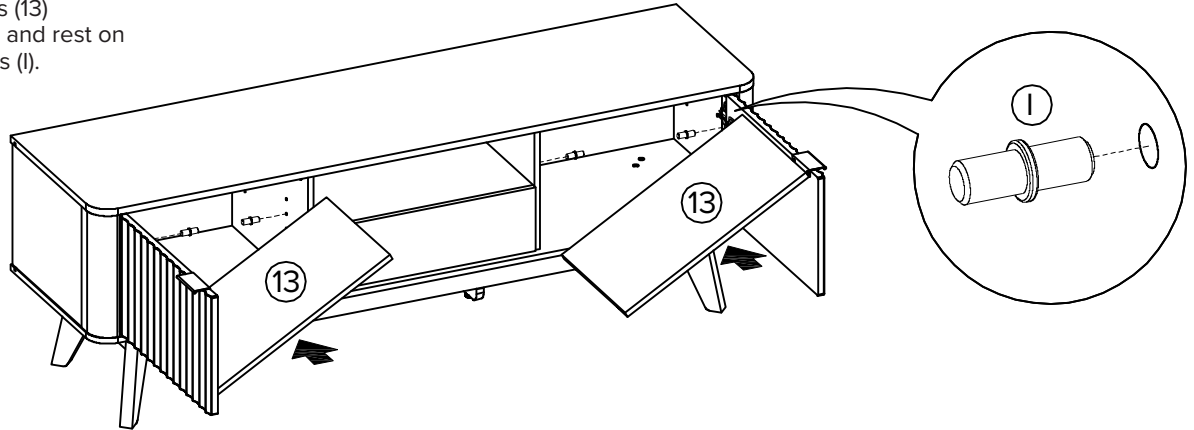

## Step 24

Lift the product to your desired position. Once on the right position, adjust the leveller until touch the ground.

Remember to always lift when moving the product. Do not drag.

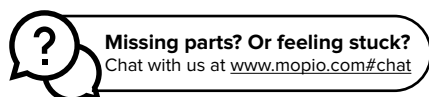
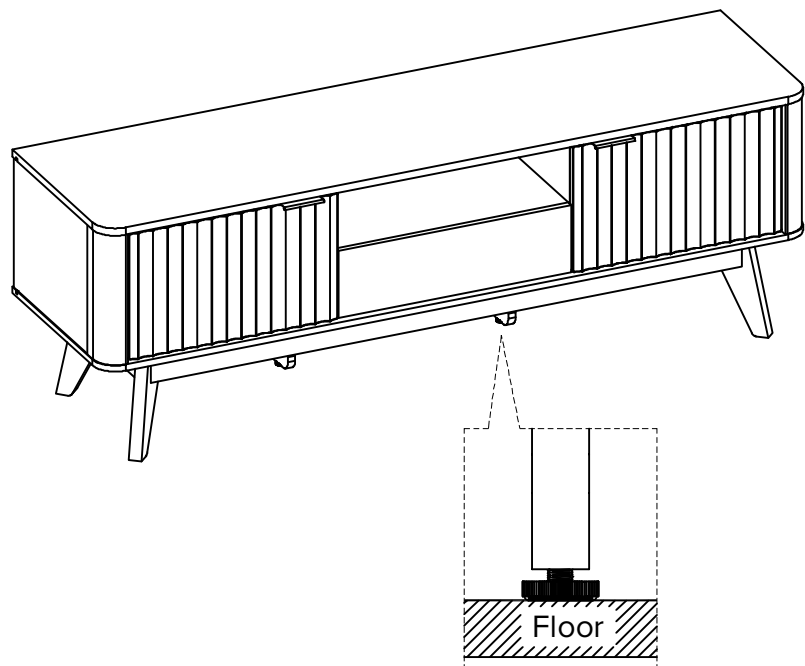

Missing parts? Or feeling stuck?  
Chat with us at [www.mopio.com#chat](https://www.mopio.com#chat)



Watch demo video at:  
<https://bit.ly/3syt2Lk>

# Finished!

---

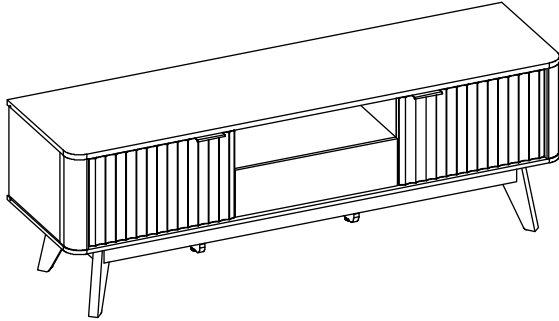

**Congratulations, you have made it through the assembly process! We're almost there! ☆**

**Please perform following checks to ensure assembly is properly done.**

- Ensure all legs frame are fully tightened, please refer to Step 6 and 10.
- If the door's gap is misaligned, please refer to Step 19 & 22. Please ensure the box is square.
- If the product is imbalance, please refer to Step 19, 21 & 24 and check if the floor is uneven

**Move your Mopio product carefully, with 2 people lifting it to the preferred location. Clean the product with a damp cloth. You are all set!**

**Enjoy your fresh and updated living space thanks to the addition of your new Mopio product!**

---



**Missing parts? Or feeling stuck?**  
Chat with us at [www.mopio.com/#chat](https://www.mopio.com/#chat)



**Watch demo video at:**  
<https://bit.ly/3syt2Lk>

# Care

## Instructions

Your furniture, if treated with respect and love, will last you a long time. Each piece requires light maintenance to maximize its longevity.

### **Few quick tips before using this product:**

1. Recommended weight limit for the table top is 70lbs and 15lbs for each storage compartment.
2. Avoid uneven weight distribution for long time as it may cause damage to the product shape.
3. Check and tighten the camlock and screw periodically as it may loose over the time.

### **How to take care of it?**

1. Avoid direct sunlight or use curtains or blinds to limit the sun exposure to the product.
2. Clean the product regularly with a dry, soft cloth.
3. Avoid using abrasive or liquid cleanser.
4. Avoid placing hot objects onto the table top surface.
5. Spillage may damage the surface. Clean immediately with a dry cloth.
6. We recommend using placemats or coasters underneath glasses, cups, bowls or plates to prevent scratches to the table surface.

Follow the care instructions and look after your furniture, in return, your furniture will look after you.

We hope to see you soon!

# Frequently Asked Questions

## 1. What should I do if my product received is incomplete?

Mopio products are flat packed and come in separate boxes. Once your order has dispatched and been sent with Fedex, you will receive an email with tracking information. Please note that Fedex may deliver your boxes in separate deliveries. Kindly follow the tracking information, allowing all boxes to be received before starting assembly. If you need further assistance on deliveries tracking, feel free to reach out to us at [www.mopio.com#chat](http://www.mopio.com#chat) or [help@mopio.com](mailto:help@mopio.com).

## 2. What should I do if my shipment is damaged or products received are defective?

We're sorry to hear that! Please email us at [help@mopio.com](mailto:help@mopio.com) or chat with us at [www.mopio.com#chat](http://www.mopio.com#chat) and provide a detailed description of the damage, as well as photos (or videos, where appropriate) showing the damage. We will do our best to resolve the issue as soon as possible.

## 3. Can replacement parts be ordered?

Yes. Simply write to our customer service team at [help@mopio.com](mailto:help@mopio.com) or chat with us at [www.mopio.com#chat](http://www.mopio.com#chat), let us know your order ID and we will be happy to assist further.

## 4. Who do I contact for repair queries?

You may write to us at [help@mopio.com](mailto:help@mopio.com) specifying your queries and we will be able to assist you further.

## 5. What warranty do you offer for your products?

You'll just need to submit your warranty registration upon receiving product at [www.mopio.com/warranty/register](http://www.mopio.com/warranty/register). You can print a copy of your order from Order Details in Amazon and upload it as your proof of purchase. More details can be found in **Warranty section**.

## 6. How do I claim my warranty?

Easy! Just email us at [help@mopio.com](mailto:help@mopio.com) and provide a detailed description of the fault as well as photos.

## 7. What should I do if I want to return the product?

We offer 30-day return policy upon product received. To initiate a return request, please message us through Amazon or contact our customer service team at [help@mopio.com](mailto:help@mopio.com) or [www.mopio.com#chat](http://www.mopio.com#chat) with your reason of returning so we can facilitate the request and assist you further. For more details on the return policy, please refer to **Return section**.

# Warranty & Return

## **1 YEAR LIMITED WARRANTY STATEMENT FOR MANUFACTURING DEFECTS**

Please read this limited warranty carefully. To maintain your warranty, you will need to comply with the conditions stated here. This warranty is for manufacturing defects only and does not cover damages as a result of misuse.

1. Please be sure to register your product at [www.mopio.com/warranty/register](http://www.mopio.com/warranty/register) to receive up to date warranty and product information.
2. Your new product comes with 1-year warranty against manufacturing defects. The warranty starts on the date of purchase. No warranty will be honoured without an original sales receipt. The warranty and financial responsibility of the manufacturer only applies to the products itself.
3. Manufacturing defects include circumstances where the product has broken under normal use and no longer provides proper support. In the event you encounter a manufacturing defect, please stop using this product immediately and contact customer service.
4. This warranty applies only when the product has been properly used by consumers who purchased the product from authorized channels as a new product. Proper use means using the product on a level surface where all legs touch the floor with an equal distribution of weight. Proper use also means that the product was not abused by the consumer, as defined by the manufacturer. This warranty does not constitute agreement to replace other parts.
5. If the product fails due to manufacturing defects, the manufacturer will repair or replace at its discretion and reserves the right to substitute comparable materials or models and does not guarantee that the replacement part will match existing pieces.
6. In the event the product needs to be inspected by the manufacturer to determine a warranty claim, the transportation cost or removal cost is borne by the consumer.

## **MOPIO'S 30-DAY RETURN POLICY**

We believe you will be thrilled with your purchase from Mopio. That's because we go out of our way to ensure that products are designed and built to be just what you need. We understand, however, that sometimes a product may not be what you expected it to be. In that event, we invite you to review the following terms related to returning a product.

## The Return

Returns are to be made within 30 days of the date you received the product. To initiate return request, please message us or contact our customer service team at [help@mopio.com](mailto:help@mopio.com) or [www.mopio.com#chat](https://www.mopio.com#chat) with your reason of returning so we can facilitate the request and issue return authorization to you. Please note the policy is subject to the conditions below:

1. Only undamaged items in original packaging will be accepted under the Returns Policy. Any items that are not returned to us in the original packaging and/or in original condition will incur an additional handling fee (deducted from your refund). It is your responsibility to package the item sufficiently to avoid damage in transit back to us. We encourage customers to photograph the items scheduled for return and the condition of the packaging before handing over to the delivery company.
2. We will not refund a product that you have bought and received where, in our reasonable opinion, the product has: become of unacceptable quality due to fair wear and tear; misuse; using it in an abnormal way; or failure to take reasonable care.
3. We will not be able to offer standard return policy after 30-day timeframe has passed. However, our customer service team is always an email away if you require further assistance with your Mopio products.

## The Refund

We will assist you to complete the return process. We will perform standard inspection upon your return is received and will send you a message to acknowledge the return if item is presenting in original condition with original packaging.

You will be refunded the full amount less return shipping cost. Please note that while shipping charges on original deliveries are subsidized, on returns the full shipping amount paid by Mopio to the delivery partner will be deducted from your refund. **All refunds will take 2 business days to process upon return acknowledgement from us, however actual fund reversal date will depend on your card company's own processing schedule.**

Kindly note, in the event of returning a defective or damaged item, **we will however absorb the shipping charges and ensure your return/exchange experience is hassle free.**

## The Exchange

We put quality as one of our top priorities – we work with experienced manufacturers and have every piece of Mopio product going through strict quality control process. We want to make sure your Mopio product reaches you safe and sound, however we are happy to do an exchange in case you receive a defective or damaged product due to any unforeseen hiccups throughout the journey. Please message us or email us at [help@mopio.com](mailto:help@mopio.com) with proof of defect or damage, our customer service will evaluate the exchange request, and assist you throughout the process accordingly.