

# TED NIGHTSTAND

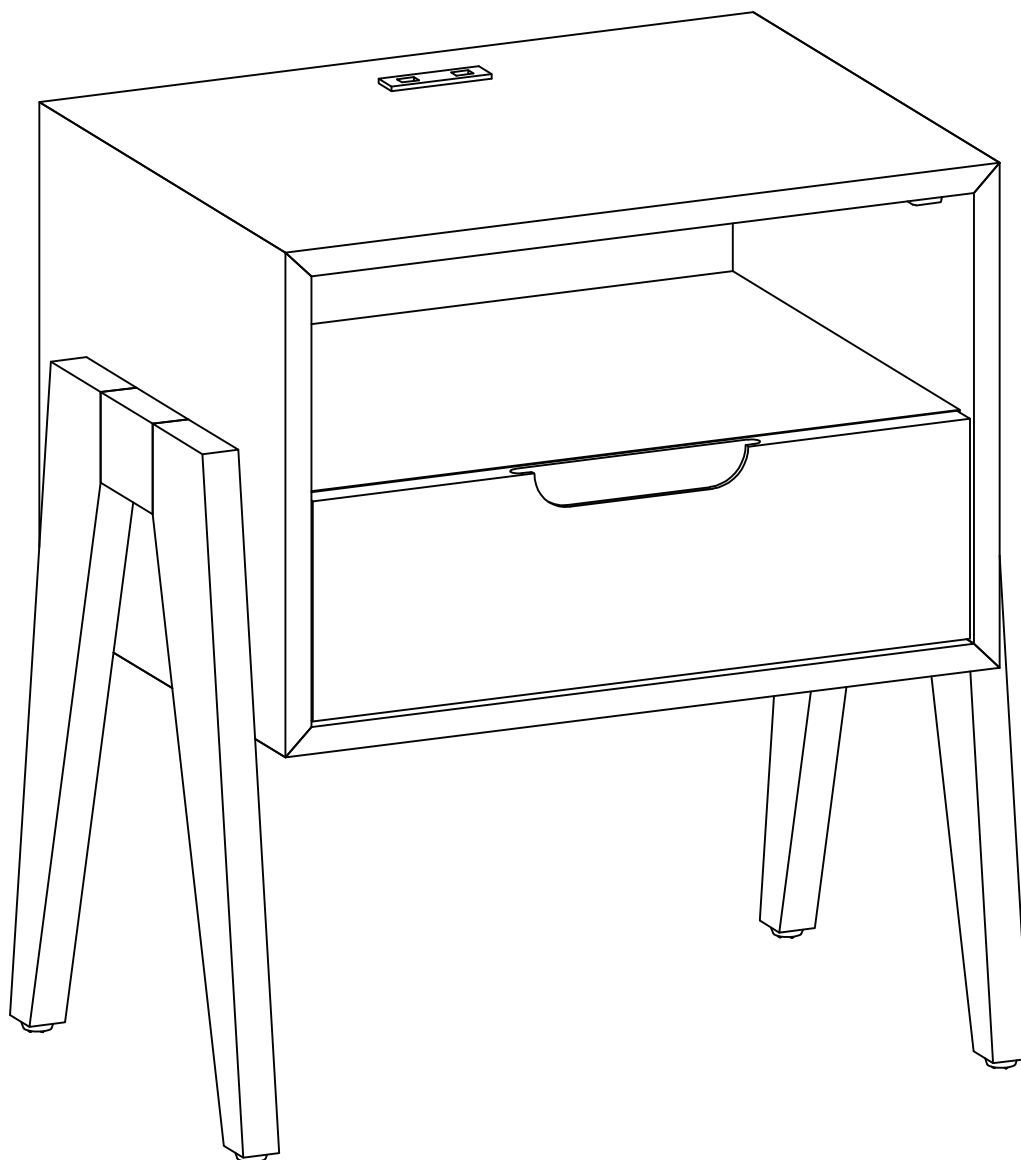

ASSEMBLY INSTRUCTIONS

**mopio**<sup>®</sup>

# Join Mopio Club and enjoy your 1-Year Warranty

We've got more for you. Be part of **Mopio Club** and enjoy:

- Privileged Customer Care
- 10% Off Your Next Purchase (no min spend)
- 1-Year Free Warranty
- Early Access To Upcoming Launches

Scan the QR code or go to the link to find out more: [www.mopio.com/club](http://www.mopio.com/club)



## Chat With Us!

For any enquiries or issues regarding your purchase, chat with us at [www.mopio.com/chat](http://www.mopio.com/chat).

 [help@mopio.com](mailto:help@mopio.com)

  [@mopioinc](https://www.instagram.com/mopioinc)

 [www.mopio.com](http://www.mopio.com)

# Before you start...

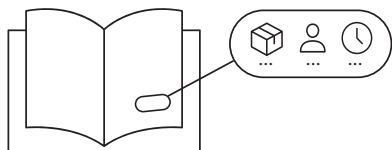

Ensure you have received all cartons and familiarize yourself with the workload. Make sure there are enough helping hands to assist you, and that you have allocated the time required to assemble your new product.

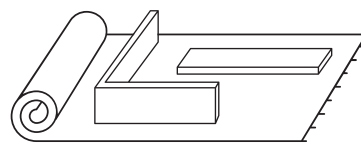

Make sure you have cleared enough space in your home for the assembly. We recommend protecting your floor with a mat or cardboard to avoid scratches during the assembly process.

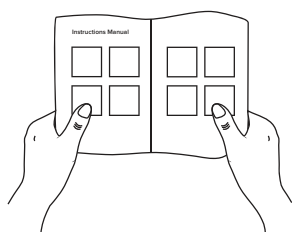

Read instructions carefully and check no parts are missing.

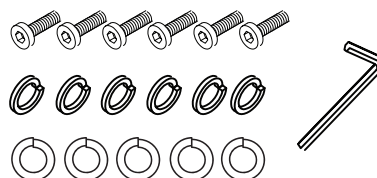

Lay out all hardware on a soft surface so you can easily identify them.

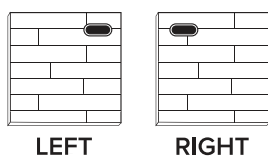

Carefully identify all components in order to differentiate which pieces are left and right.

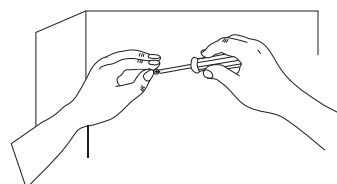

Install your new product carefully following the instructions. Don't skip ahead!

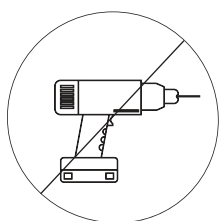

**DO NOT** over tighten screws or use a drill. It will damage the product.



If you need further assistance with assembling your Mopio product, please chat with us at [www.mopio.com#chat](https://www.mopio.com#chat).

# Parts

 **Watch installation demo video at:**  
<https://bitly.ws/TPgi>

① x1

② x2

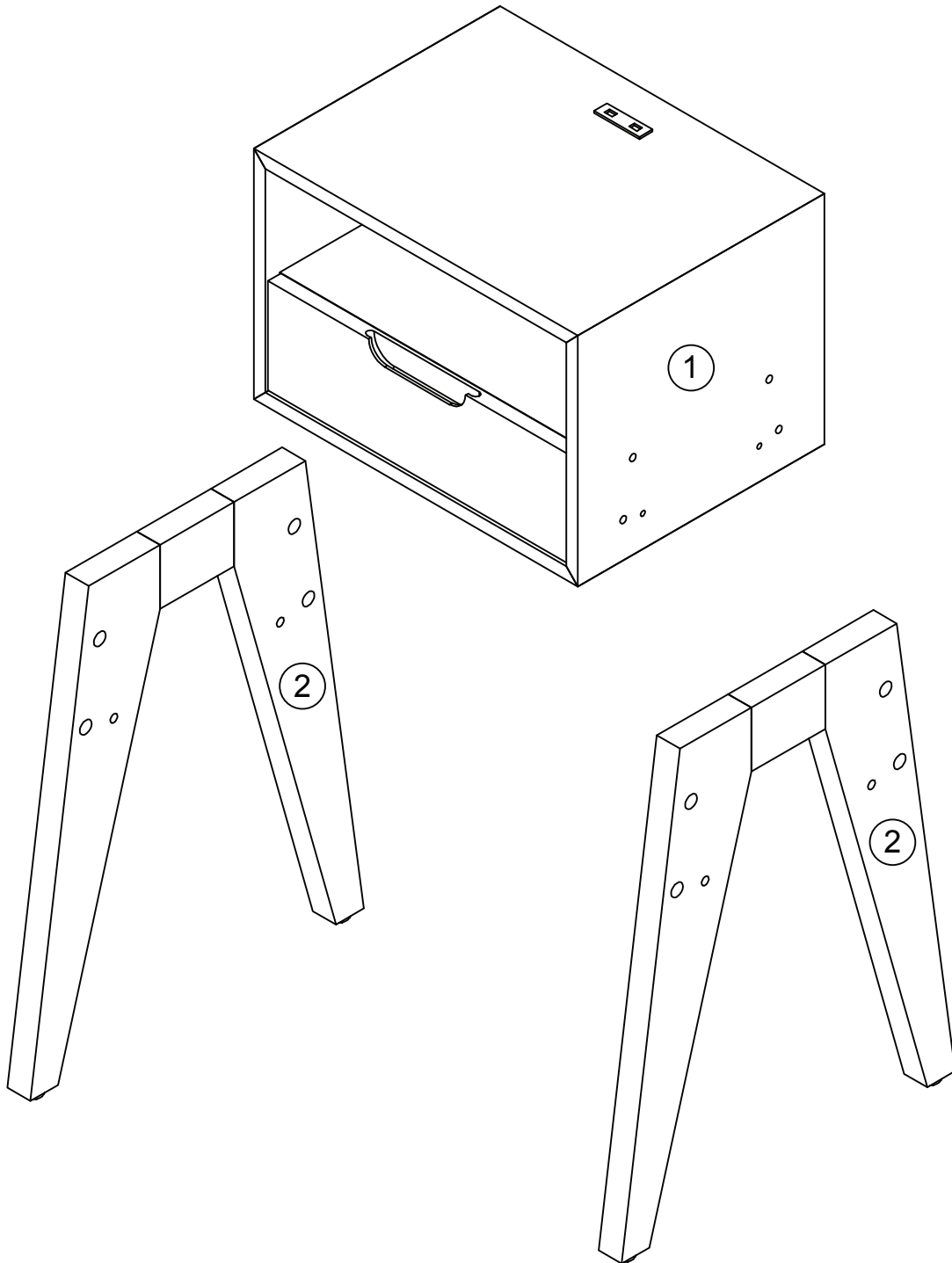



# Hardware

 **Watch installation demo video at:**  
<https://bitly.ws/TPgi>

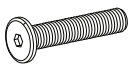
 Dowel  
Ø 8 x 30 mm  
**(A) x4**

 Bolt  
M8 x 35  
**(B) x8**

 Flat Washer  
**(C) x8**

 Spring Lock Washer  
**(D) x8**

 Allen Key  
**(E) x1**



 This product will require 15mins for assembly. We hope that you will enjoy the assembly process and hang in there!

 There are inner box(es) that include components required to complete this assembly.

 Please do not completely tighten all the hardware, until each assembly step is complete.

 Before discarding the packaging, please use the checklist to ensure that you have all the parts required to assemble your product. Please kindly note you will need the original package if you want to return the product later.

 If parts are missing or damaged, we will gladly ship your replacements parts free of charge. Please contact us at [help@mopio.com](mailto:help@mopio.com) or chat with us at [www.mopio.com#chat](https://www.mopio.com#chat).

 **x1**     **x1**     **15 mins**

# Step 1

To remove drawer from body, pull out drawer to full extension of the sliders.

Thereafter, press the retaining pins in the direction stated according to the illustration and pull drawer to remove the sliders.

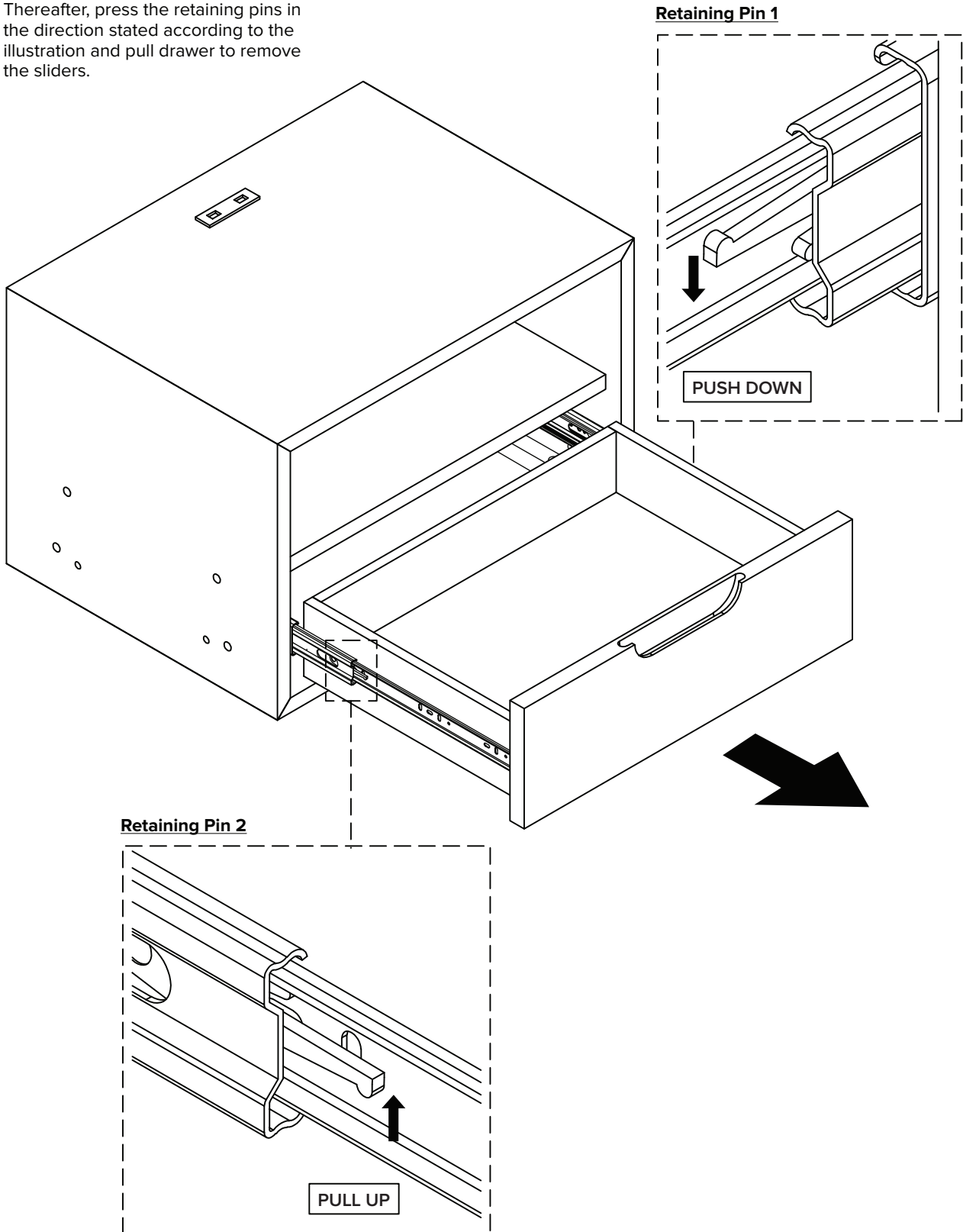



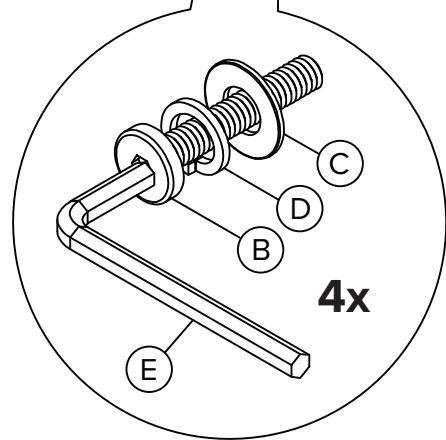
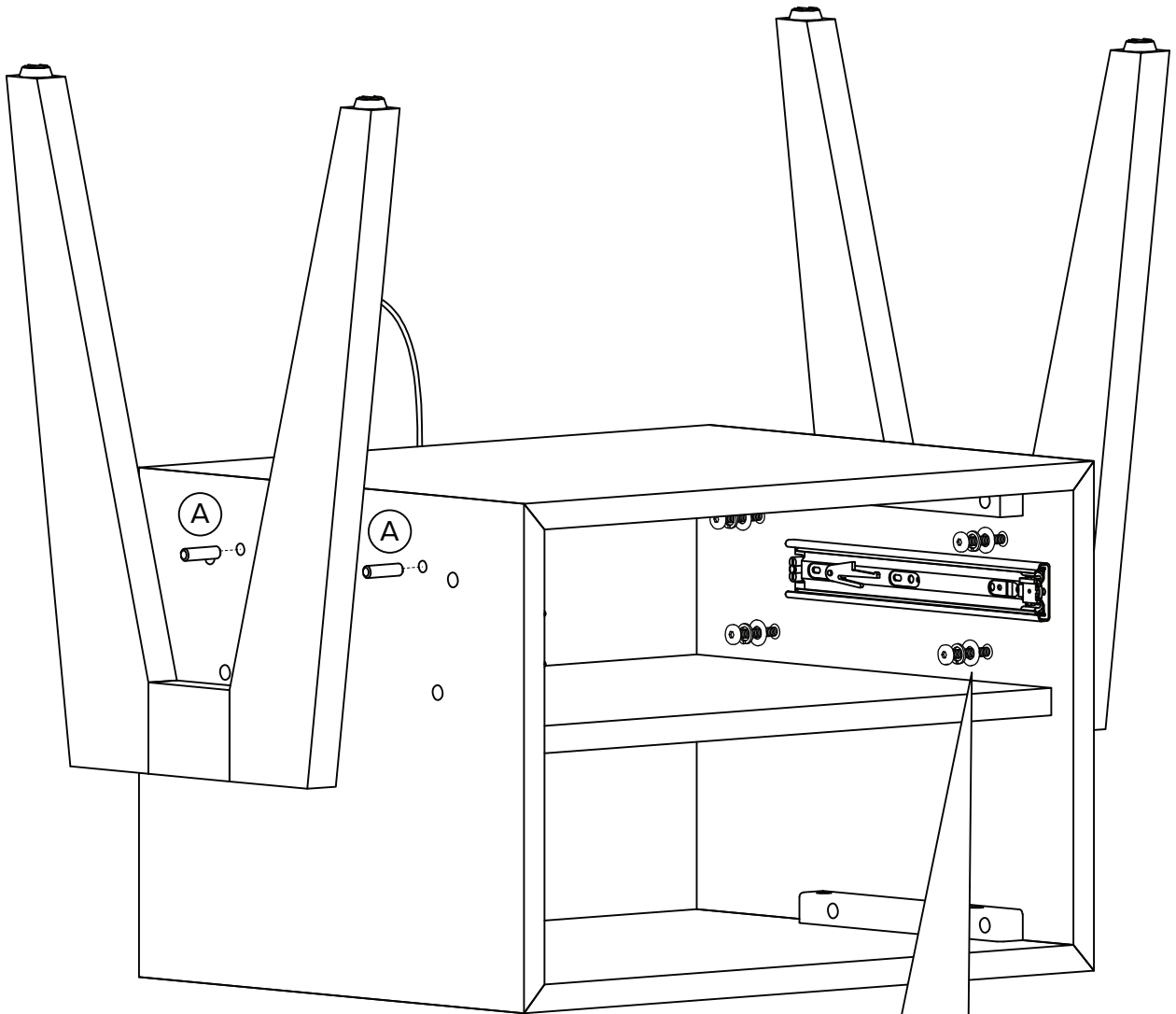

 **Missing parts? Or feeling stuck?**  
Chat with us at [www.mopio.com#chat](https://www.mopio.com#chat)

 **Watch demo video at:**  
<https://bitly.ws/TPgi>

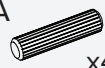
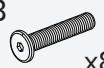
# Step 2



- A  x4
- B  x8
- C  x8
- D  x8
- E  x1

 **Missing parts? Or feeling stuck?**  
Chat with us at [www.mopio.com/#chat](https://www.mopio.com/#chat)

 **Watch demo video at:**  
<https://bitly.ws/TPgi>

# Step 3

Align the sliders and push drawer back into position. There is no need to press onto the retaining pin to install drawer.

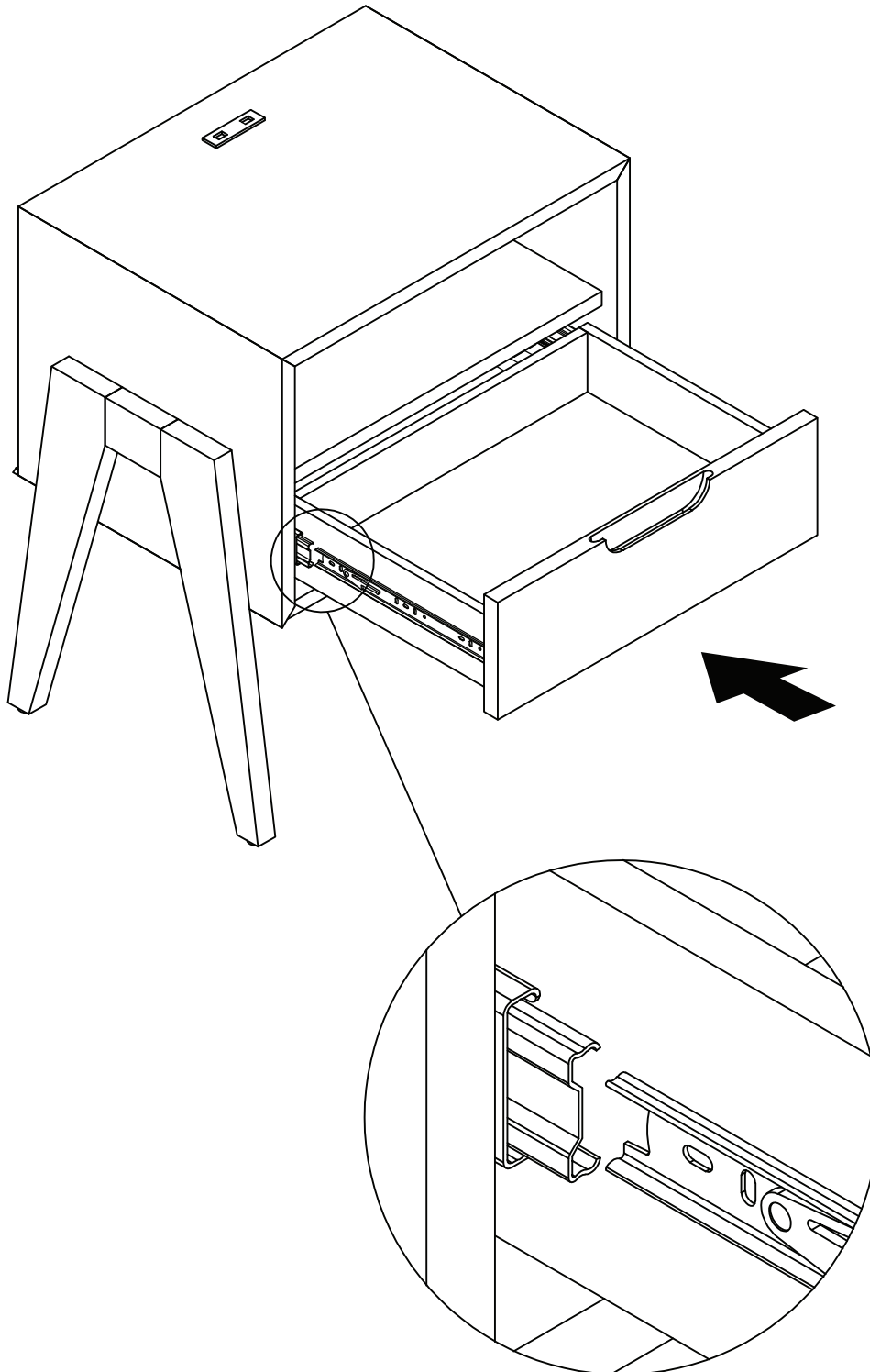

 **Missing parts? Or feeling stuck?**  
Chat with us at [www.mopio.com/chat](https://www.mopio.com/chat)

 **Watch demo video at:**  
<https://bitly.ws/TPgi>



# Finished!

---

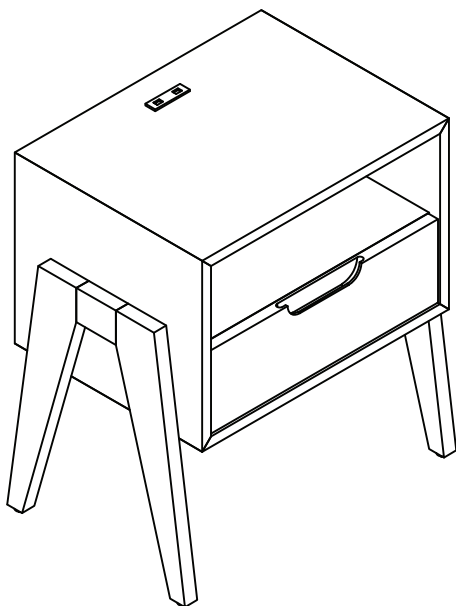

**Congratulations, you have made it through the assembly process! We're almost there!☆**

**Please perform following checks to ensure assembly is properly done.**

**Move your Mopio product carefully, with 1 person lifting it to the preferred location. Clean the product with a dry cloth. You are all set!**

**Enjoy your fresh and updated living space thanks to the addition of your new Mopio product!**

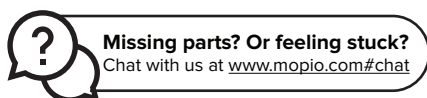

**Missing parts? Or feeling stuck?**  
Chat with us at [www.mopio.com/#chat](https://www.mopio.com/#chat)



**Watch demo video at:**  
<https://bitly.ws/TPgi>

# Important Safety Instructions

This product has a polarized plug as a feature to reduce the risk of electric shock. This plug will fit in a polarized outlet only one way. If plug does not fit fully in the outlet, reverse the plug. If it still does not fit, contact a qualified technician.

Never use wire an extension cord unless plug can be fully inserted. Do not alter the plug.

This device complies with Part 15 of the FCC Rules, Operation is subject to the following two conditions:

1. This device may not cause harmful interference and
2. This device must accept any interferences received, including interference that may cause undesired operation.

## **USB technical specs**

---

Input: 100 - 240VAC 50/60h=Hz 0.4A Max  
Output: 5VDC Max 2.4 A

# Care

## Instructions

Your furniture, if treated with respect and love, will last you a long time. Each piece requires light maintenance to maximize its longevity.

### **Few quick tips before using this product:**

1. Avoid uneven weight distribution for long time as it may cause damage to the product shape.
2. Always move the nightstand by lifting it at the base, do not drag.

### **How to take care of it?**

1. Clean the product regularly with a dry, soft cloth.
2. Avoid using abrasive or liquid cleanser.
3. Avoid prolonged exposure to direct sunlight and keep furniture away from any heating source to prevent fading or discoloration
4. Spillage may damage the surface. Clean immediately with a dry cloth.

Follow the care instructions and look after your furniture, in return, your furniture will look after you.

We hope to see you soon!

# Frequently Asked Questions

## 1. What should I do if my product received is incomplete?

Mopio products are flat packed and come in separate boxes. Once your order has dispatched and been sent with Fedex, you will receive an email with tracking information. Please note that Fedex may deliver your boxes in separate deliveries. Kindly follow the tracking information, allowing all boxes to be received before starting assembly. If you need further assistance on deliveries tracking, feel free to reach out to us at [www.mopio.com#chat](http://www.mopio.com#chat) or [help@mopio.com](mailto:help@mopio.com).

## 2. What should I do if my shipment is damaged or products received are defective?

We're sorry to hear that! Please email us at [help@mopio.com](mailto:help@mopio.com) or chat with us at [www.mopio.com#chat](http://www.mopio.com#chat) and provide a detailed description of the damage, as well as photos (or videos, where appropriate) showing the damage. We will do our best to resolve the issue as soon as possible.

## 3. Can replacement parts be ordered?

Yes. Simply write to our customer service team at [help@mopio.com](mailto:help@mopio.com) or chat with us at [www.mopio.com#chat](http://www.mopio.com#chat), let us know your order ID and we will be happy to assist further.

## 4. Who do I contact for repair queries?

You may write to us at [help@mopio.com](mailto:help@mopio.com) specifying your queries and we will be able to assist you further.

## 5. What warranty do you offer for your products?

You'll just need to submit your warranty registration upon receiving product at [www.mopio.com/warranty/register](http://www.mopio.com/warranty/register). You may provide your order ID or upload your order confirmation page as your proof of purchase. More details can be found in **Warranty section**.

## 6. How do I claim my warranty?

Easy! Just email us at [help@mopio.com](mailto:help@mopio.com) and provide a detailed description of the fault as well as photos.

## 7. What should I do if I want to return the product?

We offer a 30-day return policy upon product received. To initiate a return request, please contact our customer service team at [help@mopio.com](mailto:help@mopio.com) or [www.mopio.com#chat](http://www.mopio.com#chat) with your reason of returning so we can facilitate the request and assist you further. For more details on the return policy, please refer to **Return section**.

# Warranty & Return

## **1 YEAR LIMITED WARRANTY STATEMENT FOR MANUFACTURING DEFECTS**

Please read this limited warranty carefully. To maintain your warranty, you will need to comply with the conditions stated here. This warranty is for manufacturing defects only and does not cover damages as a result of misuse.

1. Please be sure to register your product at [www.mopio.com/warranty/register](http://www.mopio.com/warranty/register) to activate your warranty. We recommend you doing so within 30 days upon receiving.
2. Your new product comes with 1-year warranty against manufacturing defects, upon activation. The warranty starts on the date of receipt. No warranty will be honored without a proof of purchase. The warranty and financial responsibility of the manufacturer only applies to the products itself.
3. Manufacturing defects include circumstances where the product has broken under normal use and no longer provides proper support. In the event you encounter a manufacturing defect, please stop using this product immediately and contact customer service.
4. This warranty applies only when the product has been properly used by consumers who purchased the product from authorized channels as a new product. Proper use means using the product on a level surface where all legs touch the floor with an equal distribution of weight. Proper use also means that the product was not abused by the consumer, as defined by the manufacturer. This warranty does not constitute agreement to replace other parts.
5. If the product fails due to manufacturing defects, the manufacturer will repair or replace at its discretion and reserves the right to substitute comparable materials or models and does not guarantee that the replacement part will match existing pieces.
6. In the event the product needs to be inspected by the manufacturer to determine a warranty claim, the transportation cost or removal cost is borne by the consumer.

## **MOPIO'S 30-DAY RETURN POLICY**

We believe you will be thrilled with your purchase from Mopio. That's because we go out of our way to ensure that products are designed and built to be just what you need. We understand, however, that sometimes a product may not be what you expected it to be. In that event, we invite you to review the following terms related to returning a product.

## The Return

Returns are to be made within 30 days of the date you received the product. To initiate return request, please message us or contact our customer service team at [help@mopio.com](mailto:help@mopio.com) or [www.mopio.com#chat](https://www.mopio.com#chat) with your reason of returning so we can facilitate the request and issue return authorization to you. Please note the policy is subject to the conditions below:

1. Only undamaged items in original packaging will be accepted under the Returns Policy. Any items that are not returned to us in the original packaging and/or in original condition will incur an additional handling fee (deducted from your refund). It is your responsibility to package the item sufficiently to avoid damage in transit back to us. We encourage customers to photograph the items scheduled for return and the condition of the packaging before handing over to the delivery company.
2. We will not refund a product that you have bought and received where, in our reasonable opinion, the product has: become of unacceptable quality due to fair wear and tear; misuse; using it in an abnormal way; or failure to take reasonable care.
3. We will not be able to offer standard return policy after 30-day timeframe has passed. However, our customer service team is always an email away if you require further assistance with your Mopio products.

## The Refund

We will assist you to complete the return process. We will perform standard inspection upon your return is received and will send you a message to acknowledge the return if item is presenting in original condition with original packaging.

You will be refunded the full amount less return shipping cost. Please note that while shipping charges on original deliveries are subsidized, on returns the full shipping amount paid by Mopio to the delivery partner will be deducted from your refund. **All refunds will take 2 business days to process upon return acknowledgement from us, however actual fund reversal date will depend on your card company's own processing schedule.**

Kindly note, in the event of returning a defective or damaged item, **we will however absorb the shipping charges and ensure your return/exchange experience is hassle free.**

## The Exchange

We put quality as one of our top priorities – we work with experienced manufacturers and have every piece of Mopio product going through strict quality control process. We want to make sure your Mopio product reaches you safe and sound, however we are happy to do an exchange in case you receive a defective or damaged product due to any unforeseen hiccups throughout the journey. Please message us or email us at [help@mopio.com](mailto:help@mopio.com) with proof of defect or damage, our customer service will evaluate the exchange request, and assist you throughout the process accordingly.