

Have Any Questions?

mopio

Chat with us at www.mopio.com#chat | We will be online from 10am to 7pm PST timing. Alternatively you can contact us at help@mopio.com

Shop With Confidence



Norwin Executive Desk

I was able to organize some of Bryce's gaming equipment with the Norwin Executive Desk by @mopioinc ! I always tell Bryce his rainbow equipment is cramping my neutral vibe ”
- L

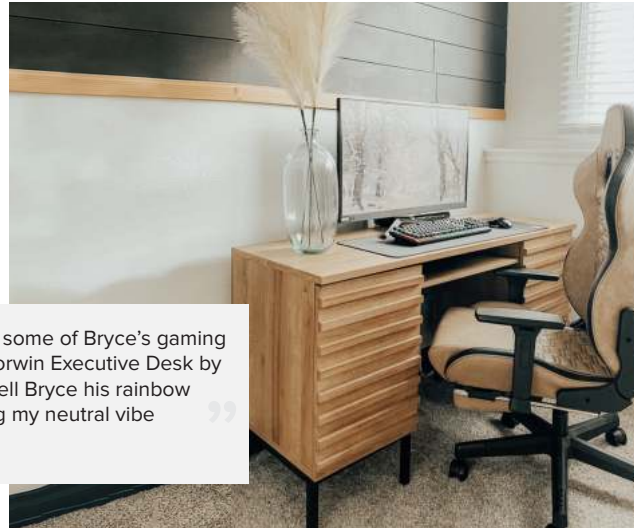

I am so very pleased with this coffee table. It looks great in our home and I love the nice walnut style. It was so easy to assemble and it's such good quality. The doors on both sides slide which the little kid in me was super entertained by. Highly recommend this piece!
- L.D



Haylee Coffee Table



Brooklyn Corner TV Stand

Parts were labeled properly and the instructions were fairly clear. It took me about 2 hours to assemble on my own, which was a bit longer than I expected, but nothing about the assembly was particularly hard.

The colour of the oak laminate was in line with the pictures and the sizing was as described. All in all, it was value for money and it uplifted our living room with its waveform panel design and gave it the mid century modern touch I wanted. ”
- L.L

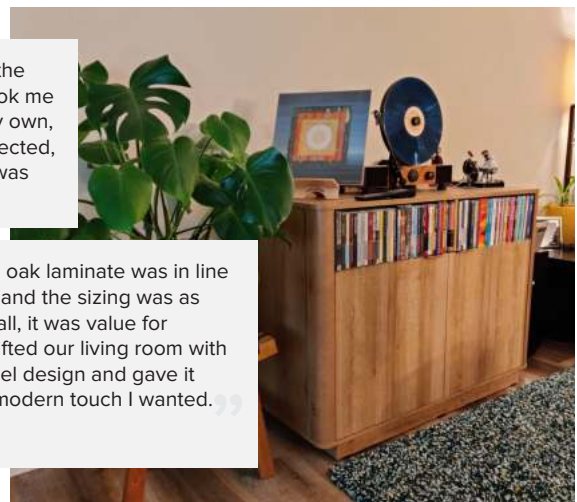

BROOKLYN CORNER TV STAND

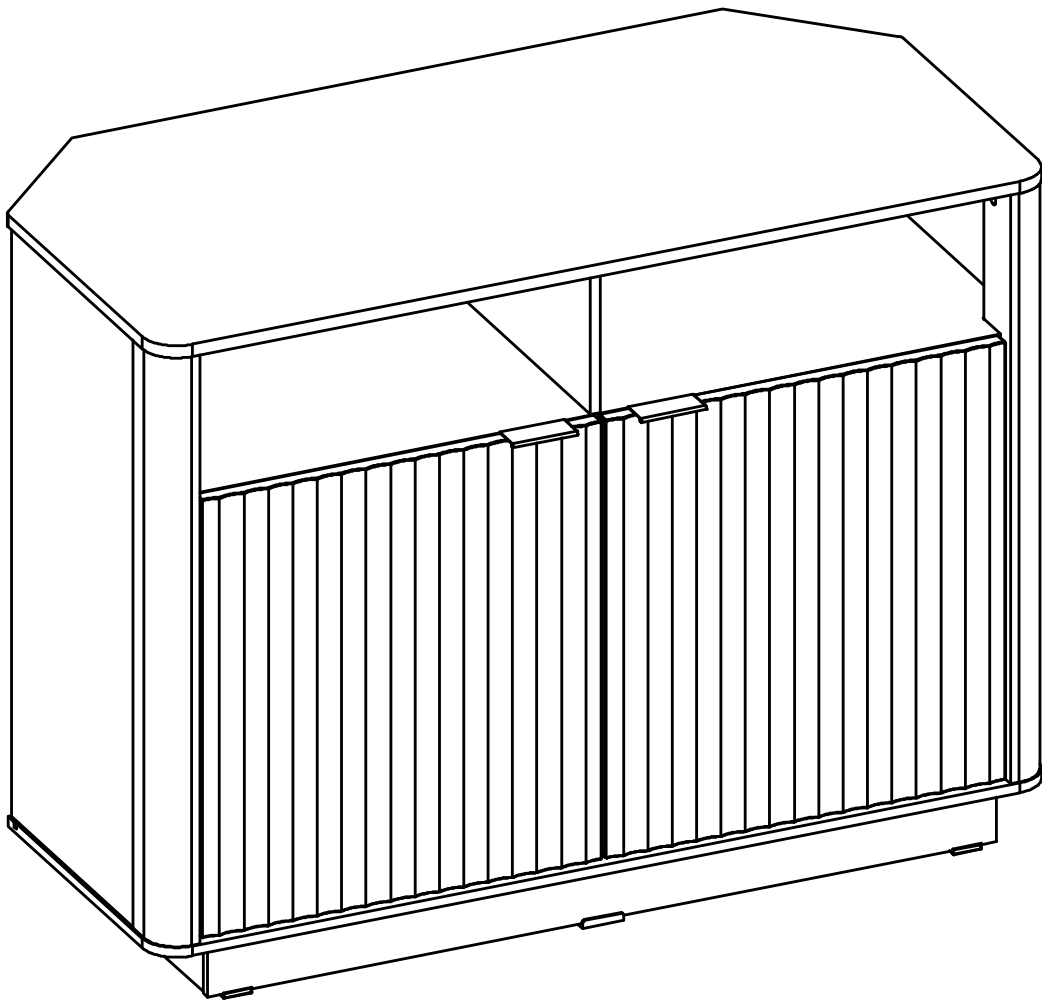

ASSEMBLY INSTRUCTIONS

mopio[®]

Join Mopio Club and enjoy your 1-Year Warranty

We've got more for you. Be part of **Mopio Club** and enjoy:

- Privileged Customer Care
- 10% Off Your Next Purchase (no min spend)
- 1-Year Free Warranty
- Early Access To Upcoming Launches

Scan the QR code or go to the link to find out more:
www.mopio.com/club



Chat With Us!

For any enquiries or issues regarding your purchase, chat with us
at www.mopio.com/chat.

Or connect with us through other channels:

✉ help@mopio.com

📘 @mopioinc

🌐 www.mopio.com

Before you start...

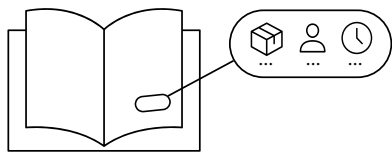

Ensure you have received all cartons and familiarize yourself with the workload. Make sure there are enough helping hands to assist you, and that you have allocated the time required to assemble your new product.

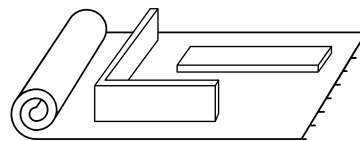

Make sure you have cleared enough space in your home for the assembly. We recommend protecting your floor with a mat or cardboard to avoid scratches during the assembly process.

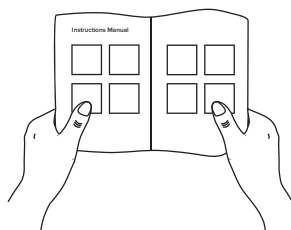

Read instructions carefully and check no parts are missing.

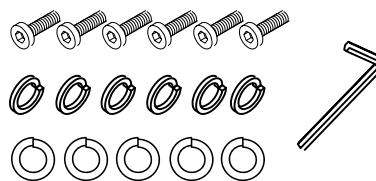

Lay out all hardware on a soft surface so you can easily identify them.

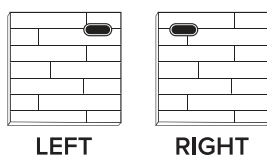

Carefully identify all components in order to differentiate which pieces are left and right.

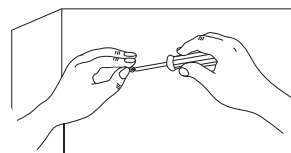

Install your new product carefully following the instructions. Don't skip ahead!

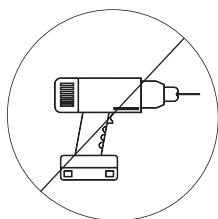

DO NOT over tighten screws or use a drill. It will damage the product.

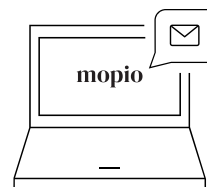

If you need further assistance with assembling your Mopio product, please chat with us at www.mopio.com#chat.

Parts



Watch installation demo video at:
<https://bit.ly/39Rn29P>



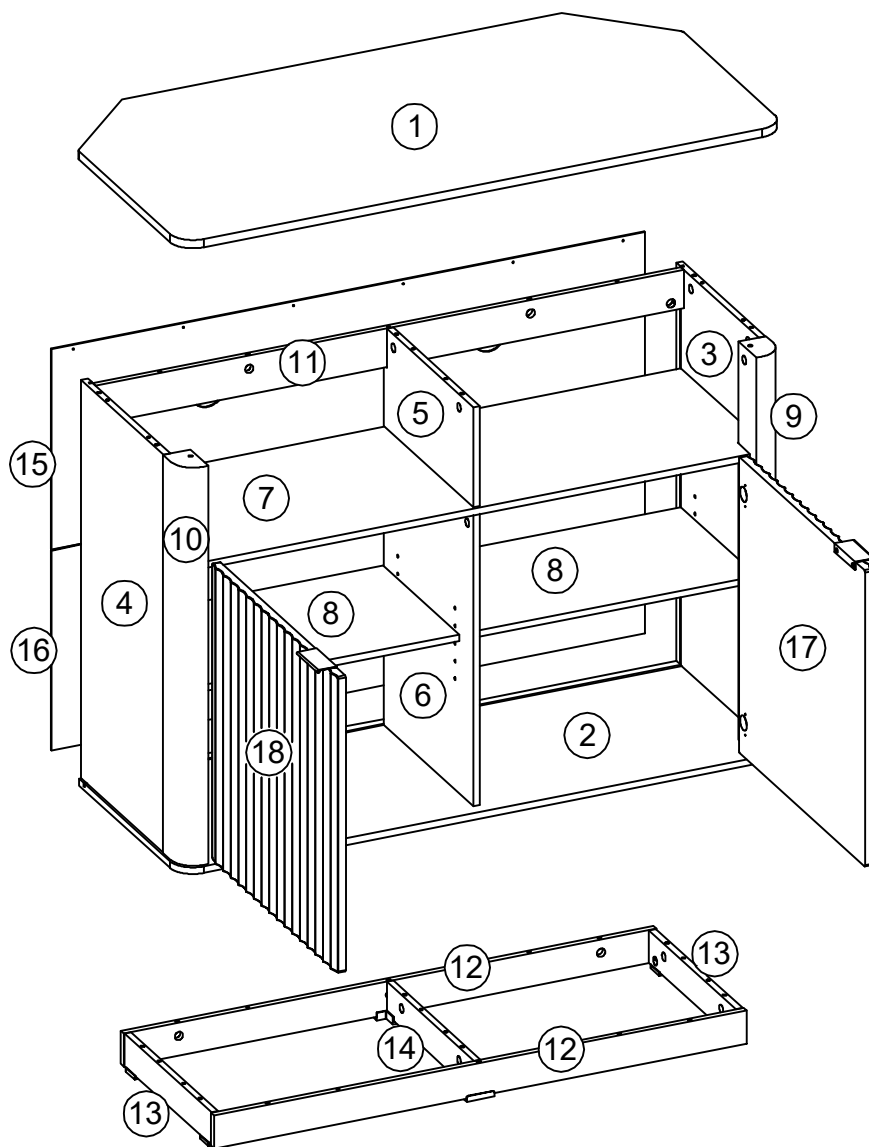







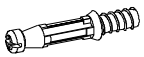





- | | |
|-------------------------------|-------------------------------|
| <input type="checkbox"/> ① x1 | <input type="checkbox"/> ⑩ x1 |
| <input type="checkbox"/> ② x1 | <input type="checkbox"/> ⑪ x1 |
| <input type="checkbox"/> ③ x1 | <input type="checkbox"/> ⑫ x2 |
| <input type="checkbox"/> ④ x1 | <input type="checkbox"/> ⑬ x2 |
| <input type="checkbox"/> ⑤ x1 | <input type="checkbox"/> ⑭ x1 |
| <input type="checkbox"/> ⑥ x1 | <input type="checkbox"/> ⑮ x1 |
| <input type="checkbox"/> ⑦ x1 | <input type="checkbox"/> ⑯ x1 |
| <input type="checkbox"/> ⑧ x2 | <input type="checkbox"/> ⑰ x1 |
| <input type="checkbox"/> ⑨ x1 | <input type="checkbox"/> ⑱ x1 |

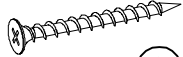

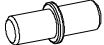
Hardware

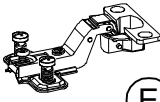
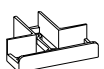
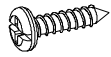

Watch installation demo video at:
<https://bit.ly/39Rn29P>

- | | | | | | | | | |
|--------------------------|---|------------------------|--------------------------|---|----------------------|--------------------------|---|----------------------|
| <input type="checkbox"/> |  | Cambolt
Ø 6 x 35 mm | <input type="checkbox"/> |  | Handle
80 mm | <input type="checkbox"/> |  | Wedge |
| | (A) | x40 | | (G) | x2 | | (M) | x12 |
| <input type="checkbox"/> |  | Camlock
Ø 15 mm | <input type="checkbox"/> |  | Screw
Ø 6 x 12 mm | <input type="checkbox"/> |  | Screw
Ø 6 x 19 mm |
| | (B) | x40 | | (H) | x12 | | (N) | x12 |
| <input type="checkbox"/> |  | Sticker
Ø 25 mm | <input type="checkbox"/> |  | Screw
Ø 4 x 13 mm | <input type="checkbox"/> |  | Screw
Ø 6 x 52 mm |
| | (C) | x24 | | (I) | x9 | | (O) | x10 |
| <input type="checkbox"/> |  | Dowel
Ø 6 x 30 mm | <input type="checkbox"/> |  | Shelf Pin | <input type="checkbox"/> |  | Wall Tipping |
| | (D) | x43 | | (J) | x8 | | (P) | x2 |
| <input type="checkbox"/> |  | Hinge | <input type="checkbox"/> |  | Foot mate | <input type="checkbox"/> |  | Screw
Ø 6 x 12 mm |
| | (E) | x4 | | (K) | x2 | | (Q) | x2 |
| <input type="checkbox"/> |  | Screw
Ø 7 x 14 mm | <input type="checkbox"/> |  | Foot mate | <input type="checkbox"/> |  | Bumper
Ø 5 x 2 mm |
| | (F) | x8 | | (L) | x4 | | (R) | x2 |



This product will require 2.5hrs for assembly. We hope that you will enjoy the assembly process and hang in there!



There are inner box(es) that include components required to complete this assembly.



Please do not completely tighten all the hardware, until the entire assembly is complete.



Before discarding the packaging, please use the checklist to ensure that you have all the parts required to assemble your product. Please kindly note you will need the original package if you want to return the product later.



If parts are missing or damaged, we will gladly ship your replacements parts free of charge. Please contact us at help@mopio.com or chat with us at [www.mopio.com#chat](https://www.mopio.com/chat).



x1



x2



2.5 hours

Step 1

Ensure your floor is properly protected, then take out panel (5), panel (6), and panel (7).

Screw Cambolt (A) to panel (7) (don't over screw).

Plug in Dowel (D) into the center holes of the each side of panels (5), (6), and (7).

*Don't screw too deep

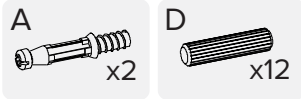
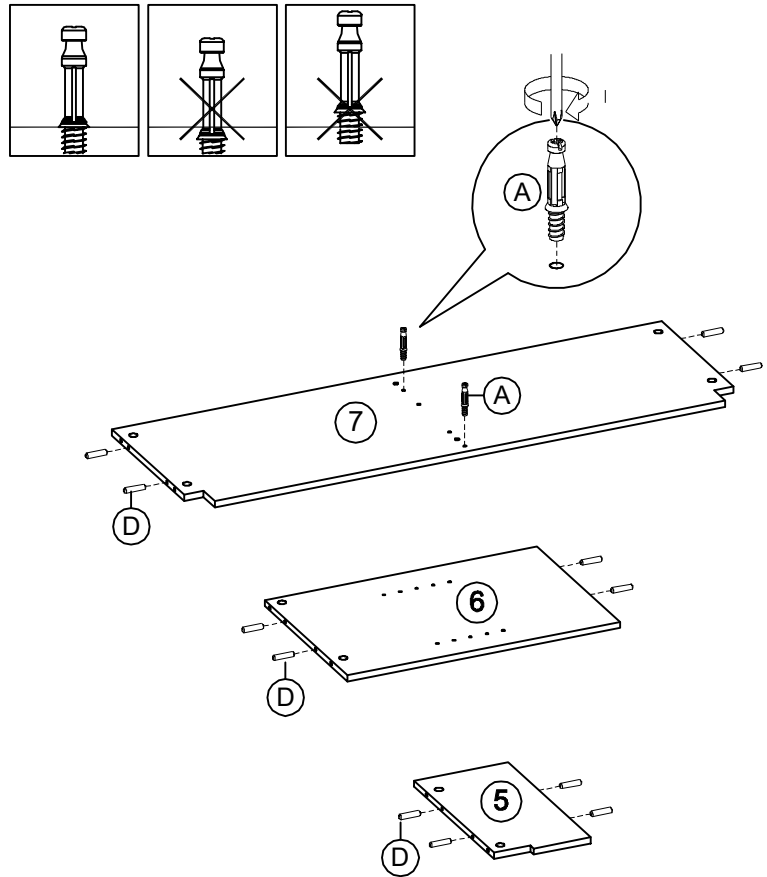

Step 2

Install panel (5) onto panel (7) by inserting screw (O) and tightening it with a screwdriver.

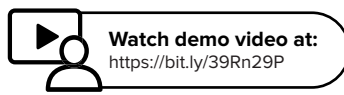
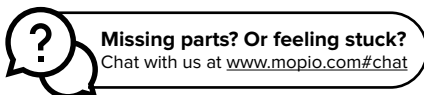
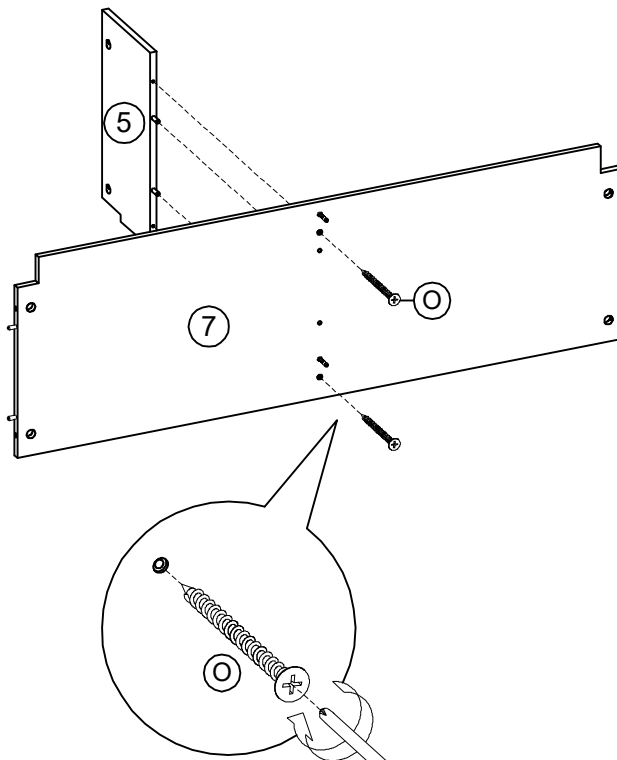

Step 3

Install panel (6) onto panel (7) by inserting camlock (B) and tightening it with a screwdriver.

Please ensure the correct camlock placing orientation. Check the illustration carefully.

Place Sticker Cam (C) over the Connecting Cams (B).

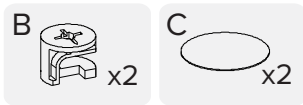
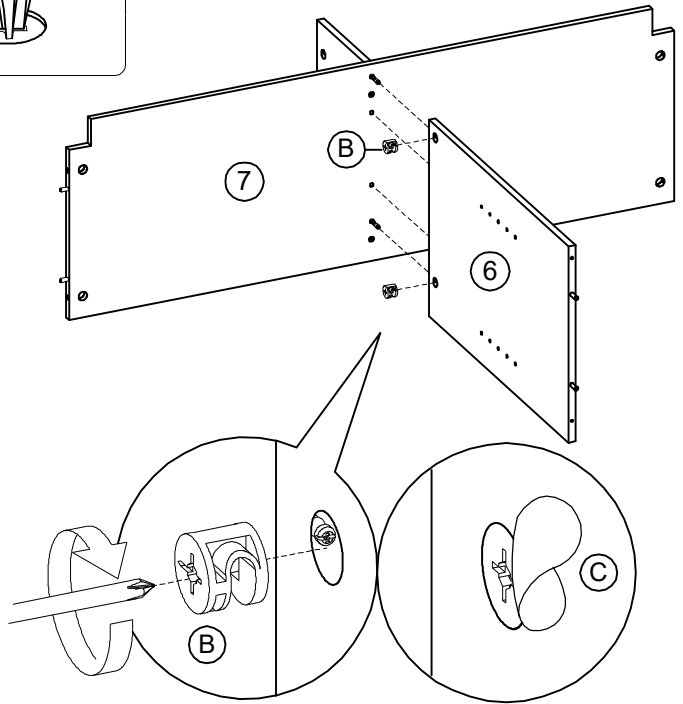
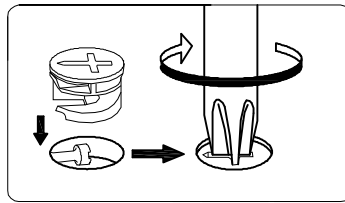

Step 4

Prepare panels (11), (3), and (4).

Screw Cambolt (A) to panel (3) and (4) (don't over screw).

Plug in Dowel (D) into the center holes of the each side of panels (11), (3), and (4).

*Don't screw too deep

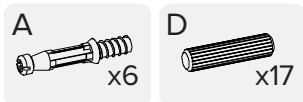
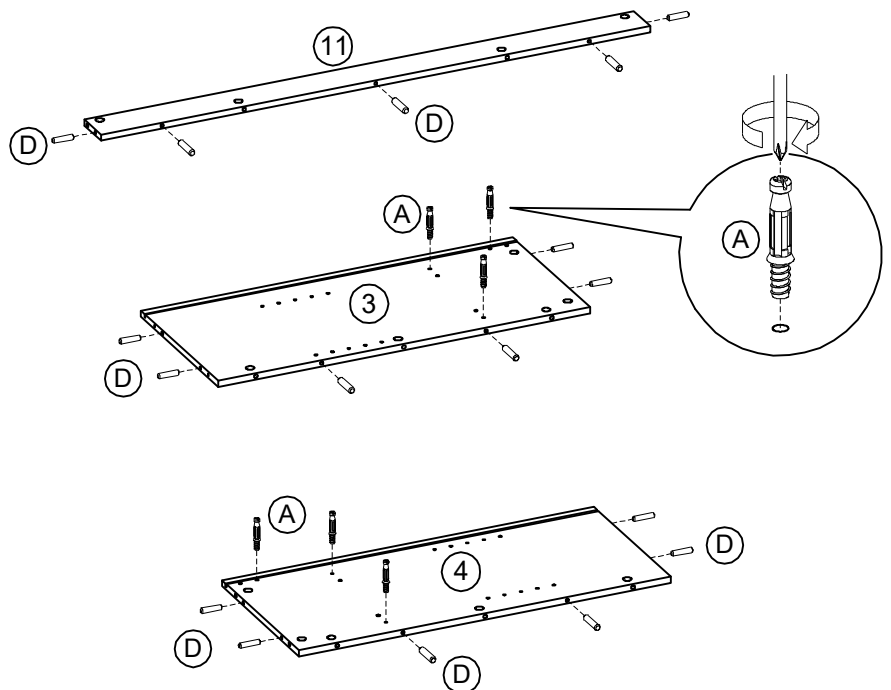
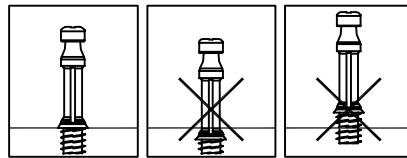

Missing parts? Or feeling stuck?
Chat with us at www.mopio.com/chat

Watch demo video at:
<https://bit.ly/39Rn29P>

Step 5

Install panel (3) onto panel (7) by inserting camlock (B) and tightening it with a screwdriver.

Please ensure the correct camlock placing orientation. Check the illustration carefully.

Place Sticker Cam (C) over the Connecting Cams (B).

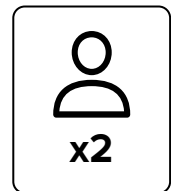
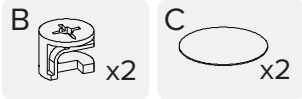
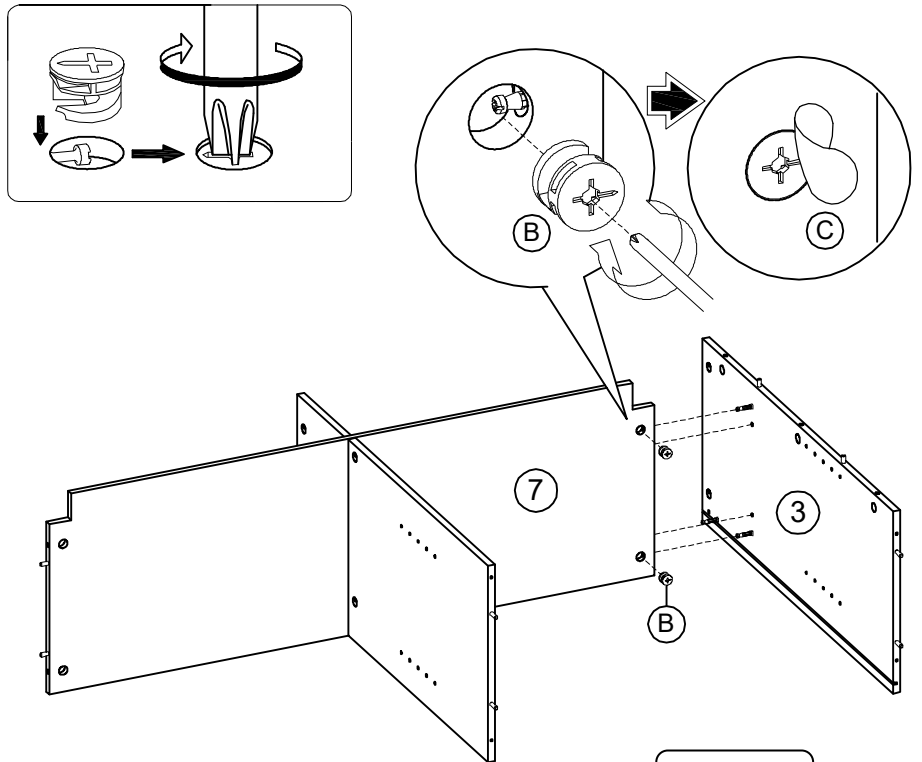

Step 6

Simultaneously install panel (4) and (11) onto the assembled unit together by inserting camlock (B) and tightening it with a screwdriver.

Please ensure the correct camlock placing orientation. Check the illustration carefully.

Place Sticker Cam (C) over the Connecting Cams (B).

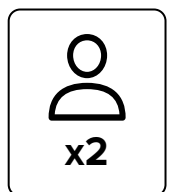
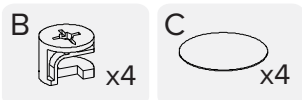
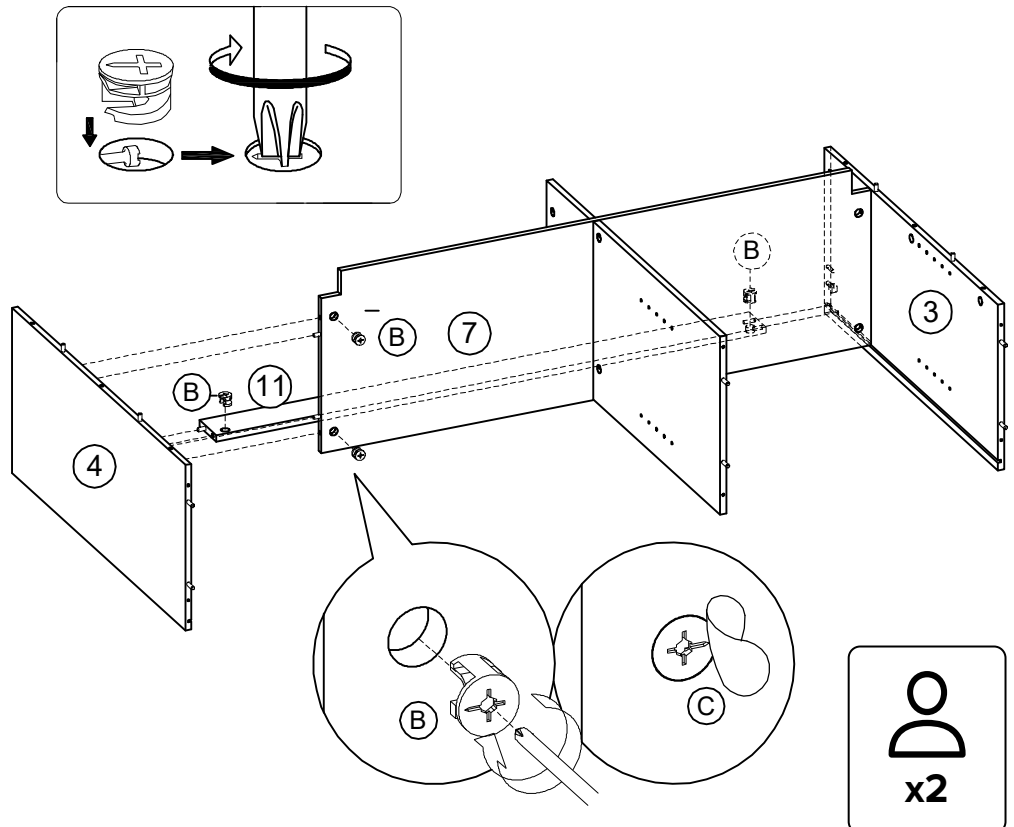

Missing parts? Or feeling stuck?
Chat with us at www.mopio.com/#chat

Watch demo video at:
<https://bit.ly/39Rn29P>

Step 7

*Don't screw too deep

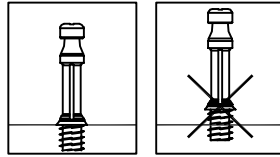

Screw Cambolt (A) to panel (2), (9), and (10) (don't over screw).

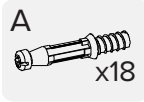
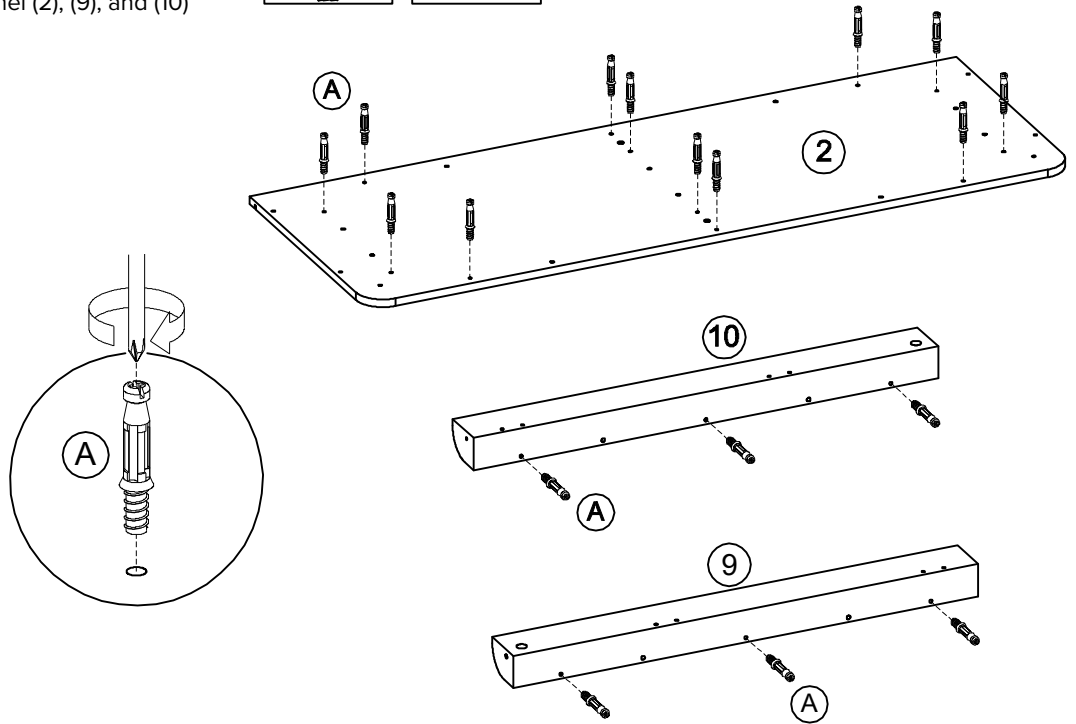

Step 8

Install panel (9) and (10) onto the assembled unit by inserting camlock (B) and tightening it with a screwdriver.

Please ensure the correct camlock placing orientation. Check the illustration carefully.

Place Sticker Cam (C) over the Connecting Cams (B).

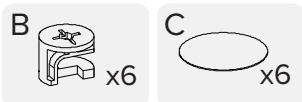
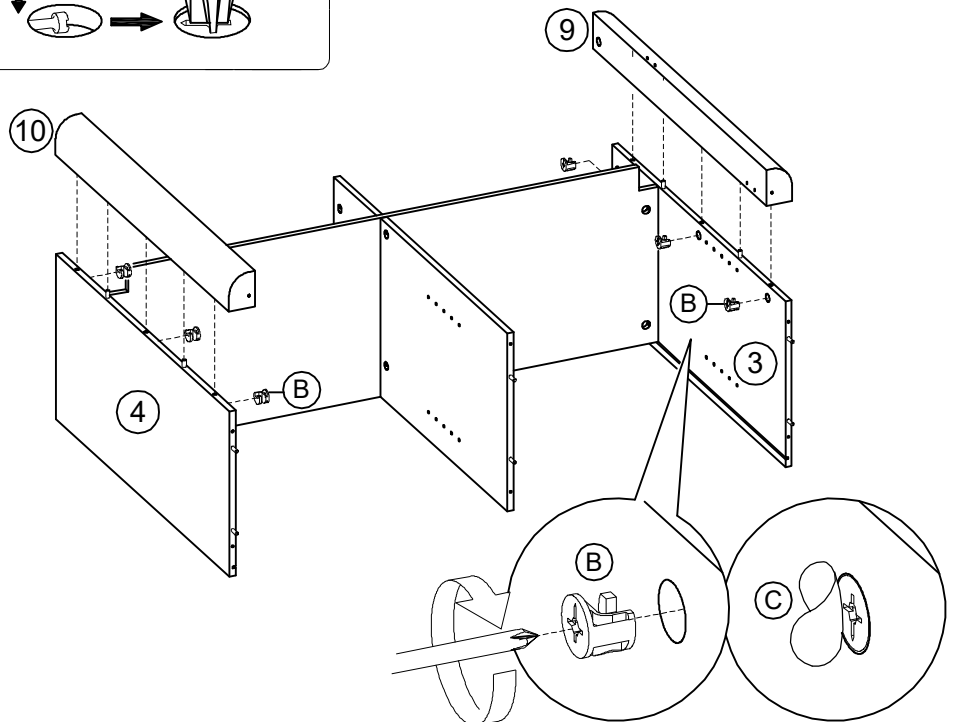
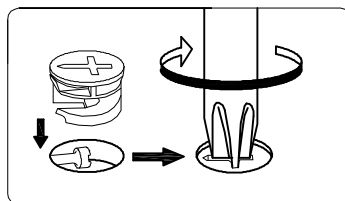

Missing parts? Or feeling stuck?
Chat with us at www.mopio.com#chat

Watch demo video at:
<https://bit.ly/39Rn29P>

Step 9

Install panel (2) onto the assembled unit by inserting screw (O) and tightening it with a screwdriver.

Please ensure you screw or plug into the correct holes according to the illustrations.

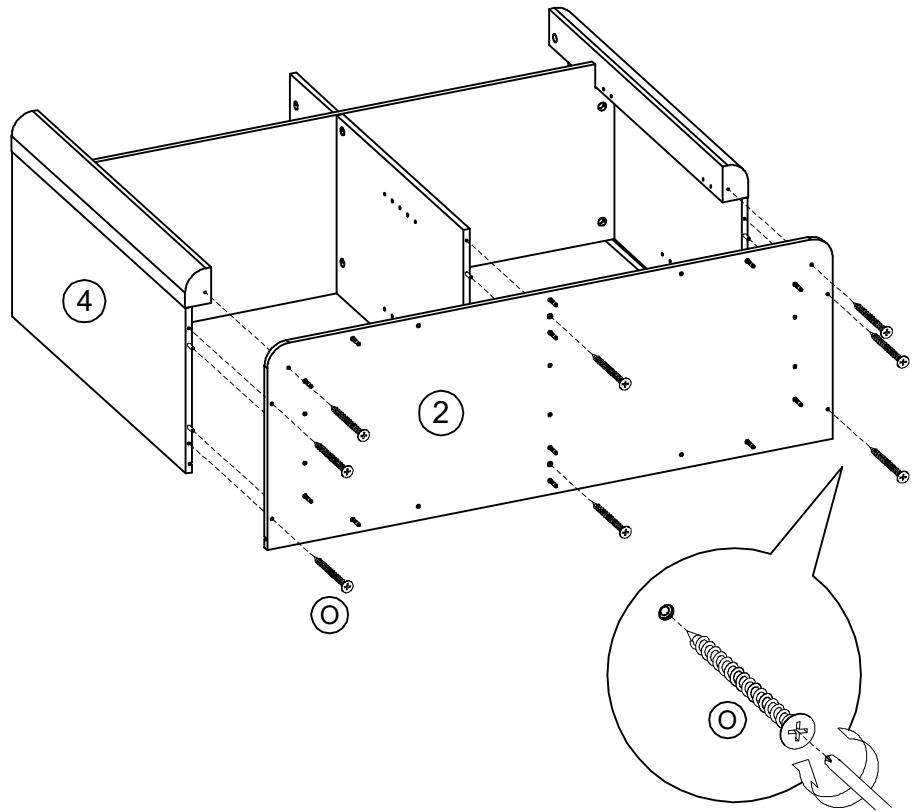

Step 10

*Don't screw too deep

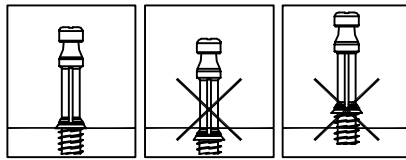

Screw Cambolt (A) to 2 pieces of panel (12) (don't over screw).

Plug in Dowel (D) into the center holes of the each side of panels (12), (13), and (14).

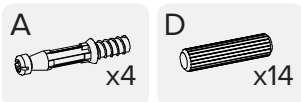
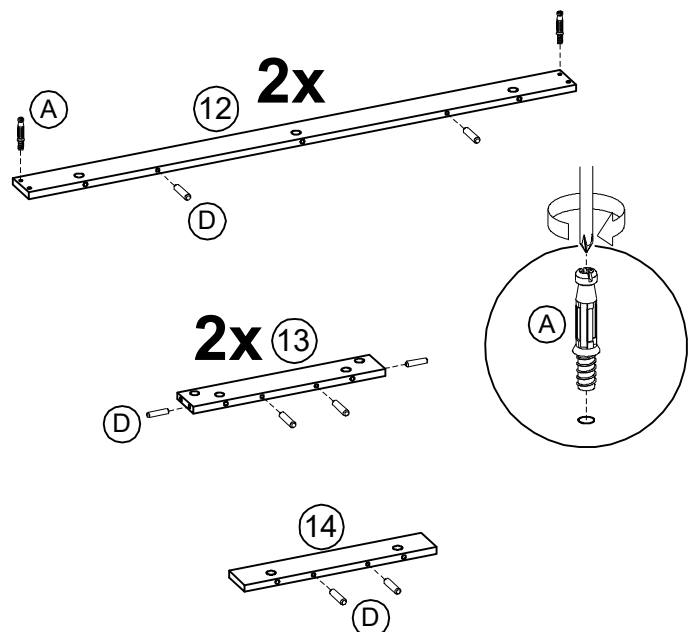

? **Missing parts? Or feeling stuck?**
Chat with us at www.mopio.com/#chat

▶ **Watch demo video at:**
<https://bit.ly/39Rn29P>

Step 11

Install 2 pieces of panel (12) and 2 pieces of panel (13) by inserting camlock (B) and tightening it with a screwdriver.

Please ensure the correct camlock placing orientation. Check the illustration carefully.

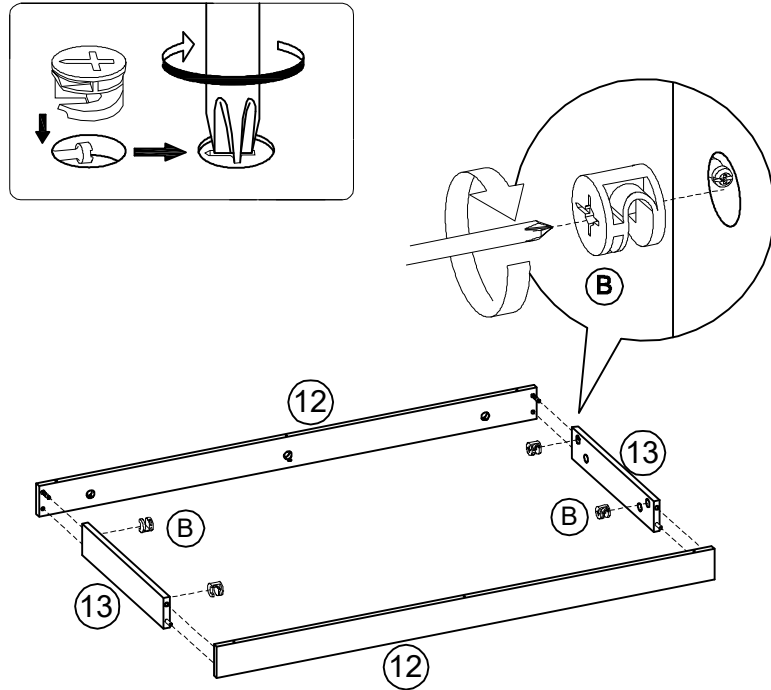

Step 12

Install the assemble unit (12 &13) onto panel (2) by inserting camlock (B) and tightening it with a screwdriver.

Install panel (14) onto the assembled unit by inserting camlock (B) and tightening it with a screwdriver.

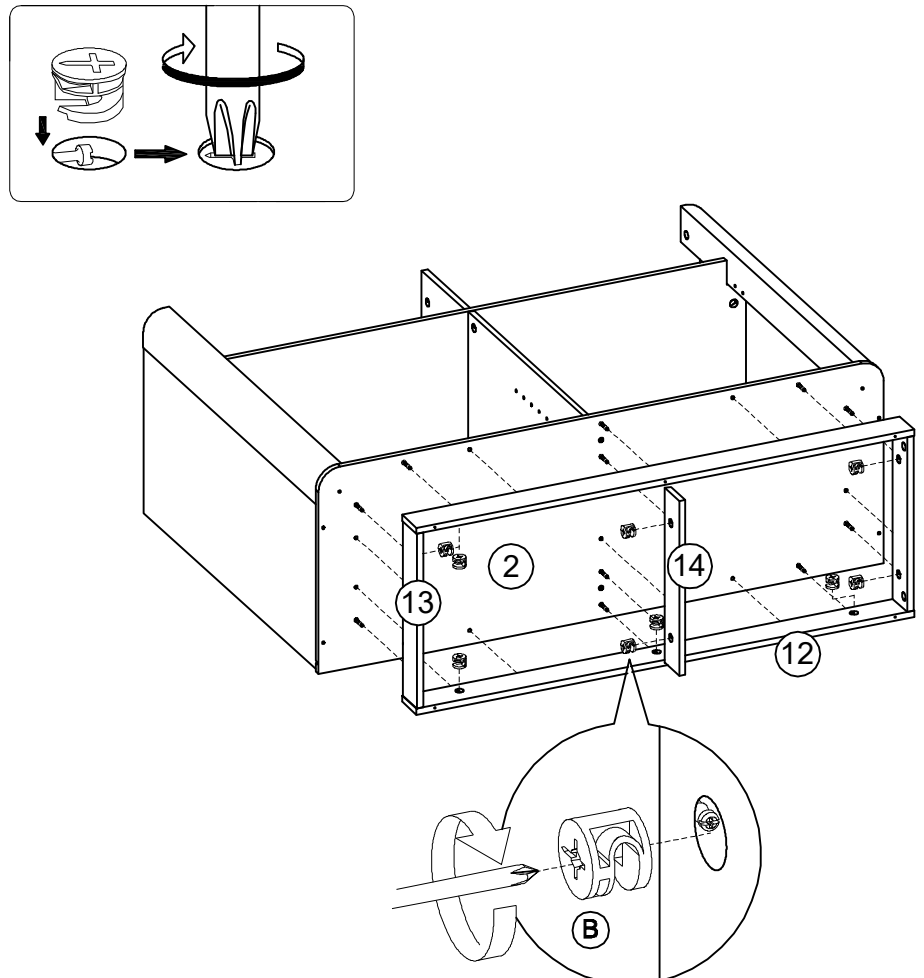

Missing parts? Or feeling stuck?
Chat with us at www.mopio.com/#chat

Watch demo video at:
<https://bit.ly/39Rn29P>

Step 13

Fasten the Foot Mate (K & L) by inserting screw (H) onto the assembled unit.

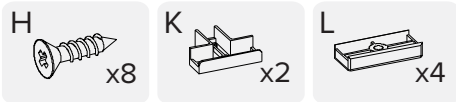
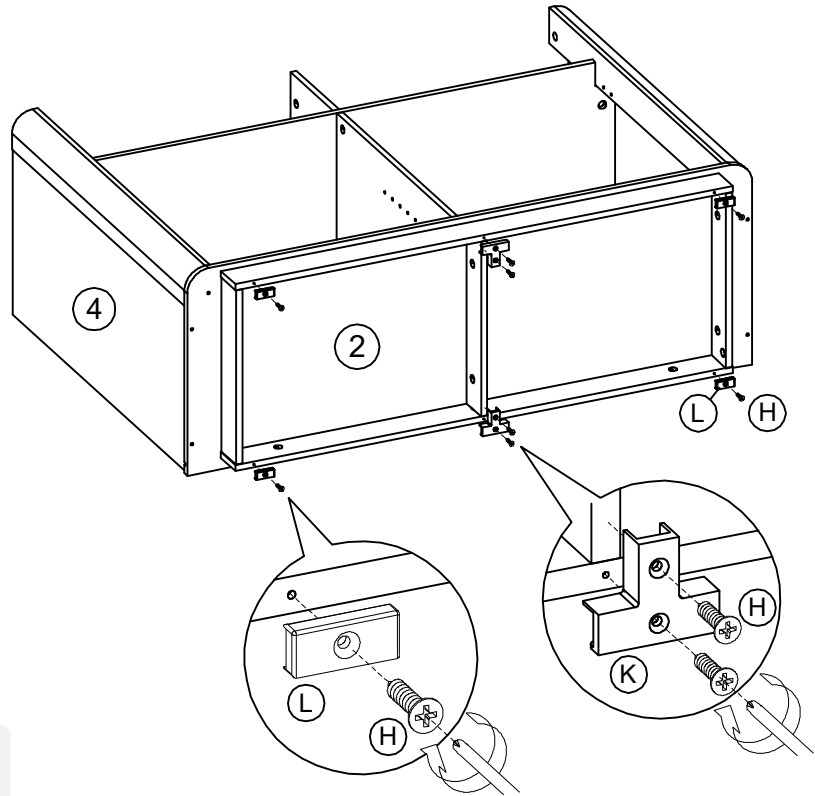

Step 14

Slide Back Panel (15 & 16) into grooves of assembled unit as shown.

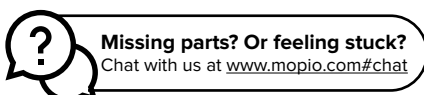
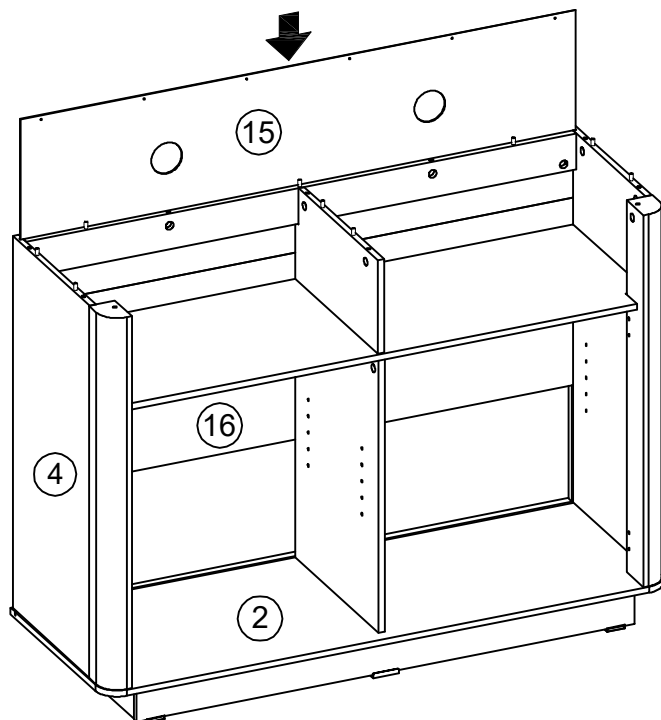

Missing parts? Or feeling stuck?
Chat with us at www.mopio.com/#chat



Watch demo video at:
<https://bit.ly/39Rn29P>

Step 15

Screw Cambolt (A) to panel (1).

Please ensure you screw or plug into the correct holes according to the illustrations.

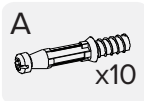
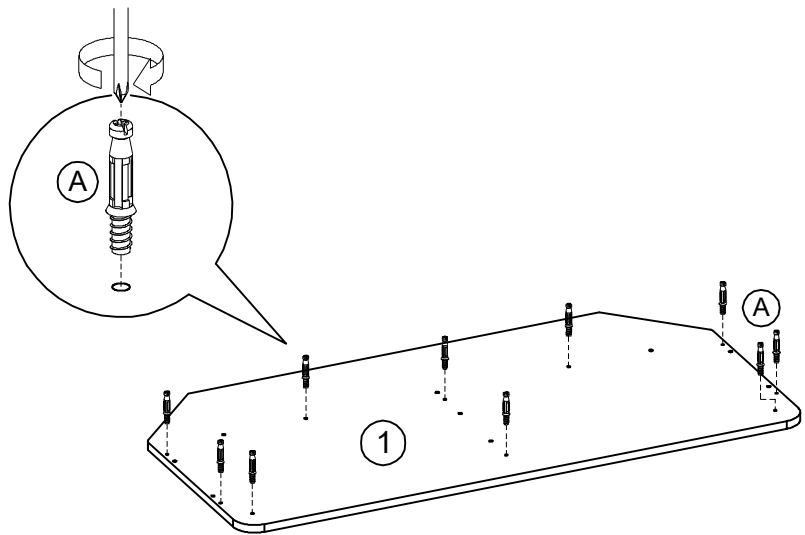

Step 16

Install panel (1) onto the assembled unit by inserting camlock (B) and tightening it with a screwdriver.

Please ensure the correct camlock placing orientation. Check the illustration carefully.

Place Sticker Cam (C) over the Connecting Cams (B).

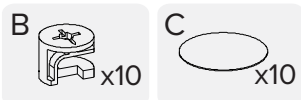
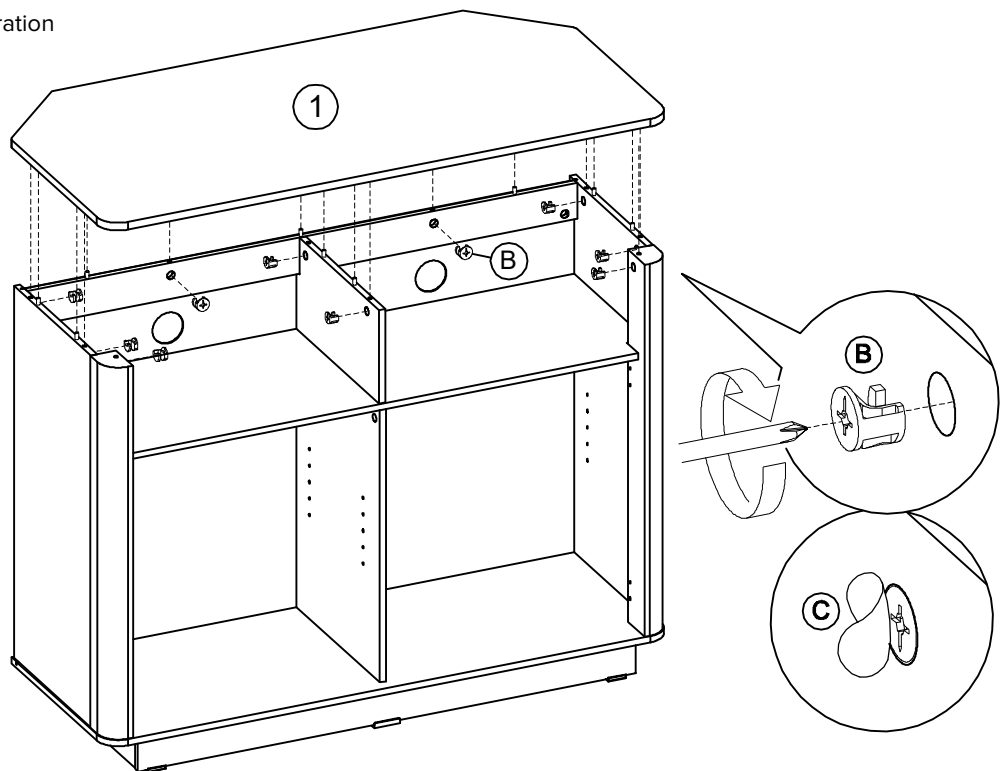
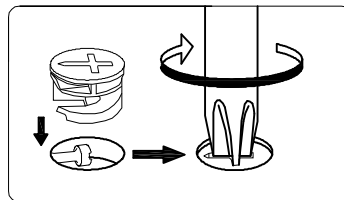

Missing parts? Or feeling stuck?
Chat with us at www.mopio.com/#chat



Watch demo video at:
<https://bit.ly/39Rn29P>

Step 17

Gently adjust Top Panel sideways in either direction until the diagonal measurements of the frame are equal.

Holding the assembly in place, fix with Screws (I) as shown.

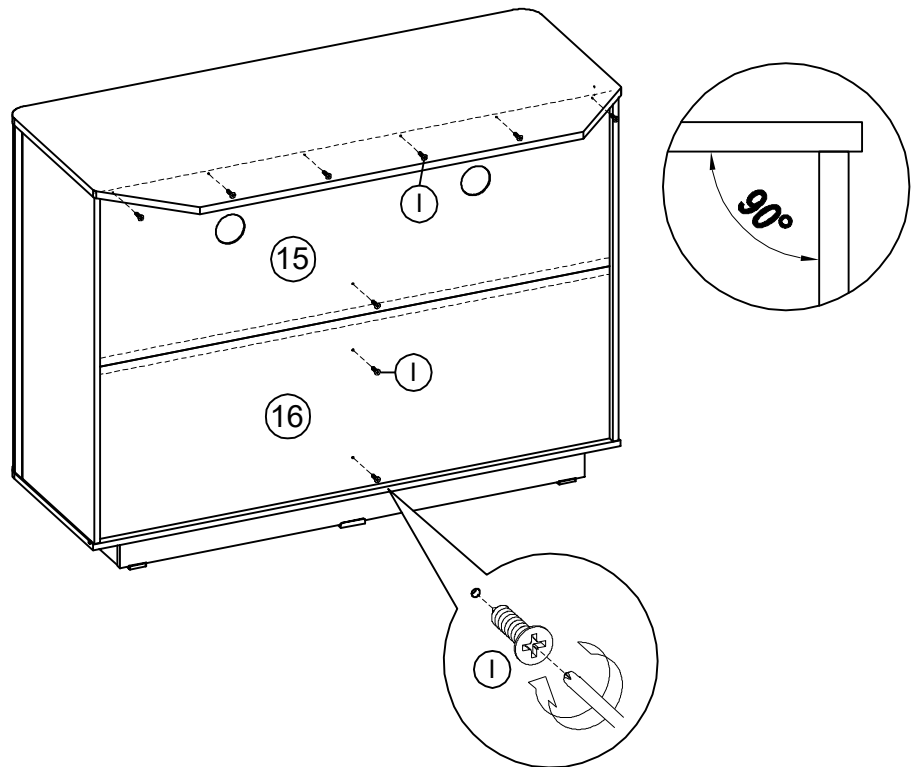

Step 18

Fix Wedge (M) into the correct holes by inserting screw (N) and tightening with a screwdriver.

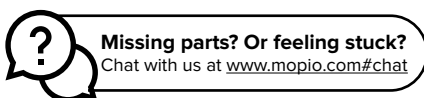
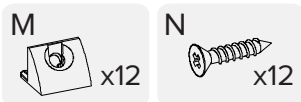
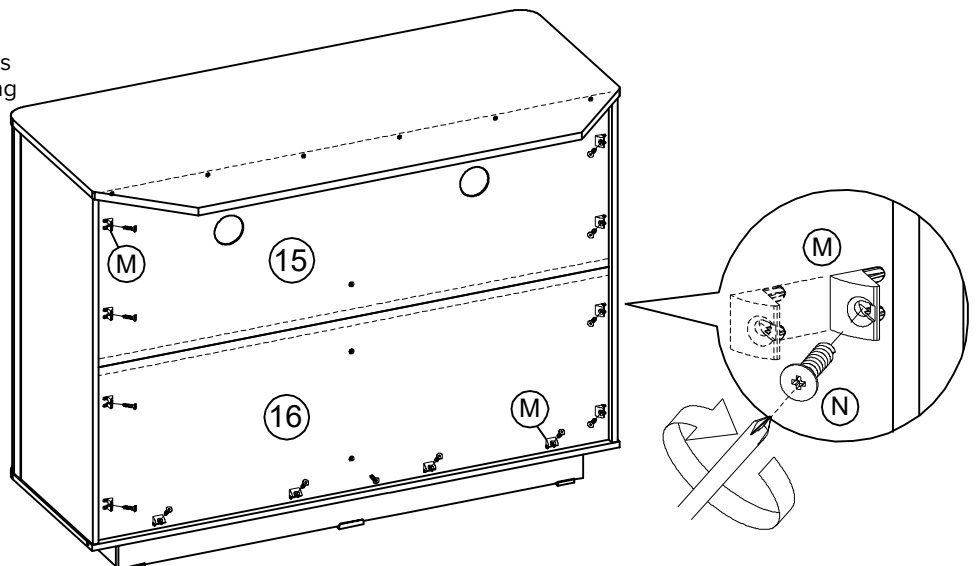

Missing parts? Or feeling stuck?
Chat with us at www.mopio.com/#chat

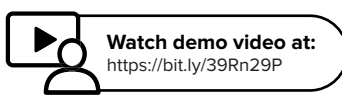

Watch demo video at:
<https://bit.ly/39Rn29P>

Step 19

Fasten Hinges (E) with Screws (F) onto door panel (17) & (18).

Fasten handle (G) with Screws (H) onto door panel (17) & (18).

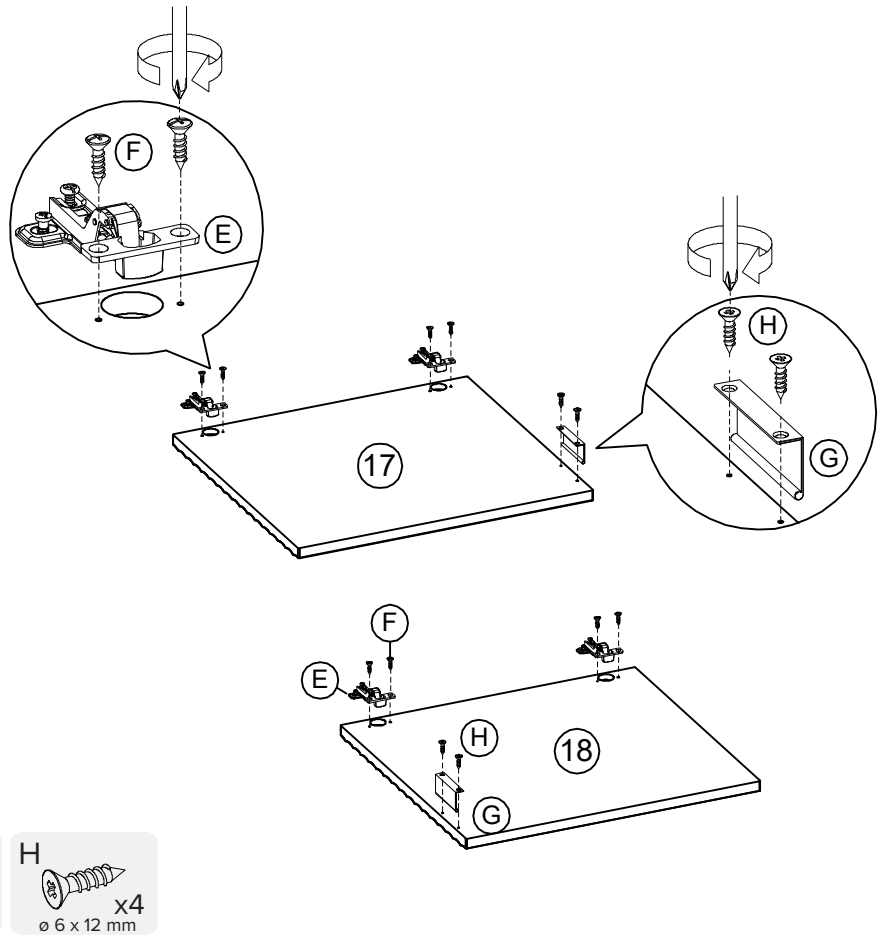

Step 20

Uneven floor may result in misaligned doors.

Insert door hinges on door panel (17) onto Right side panel with a screwdriver.

Insert door hinges on door panel (18) onto Left side panel with a screwdriver.

Adjust the alignment of the doors if necessary.

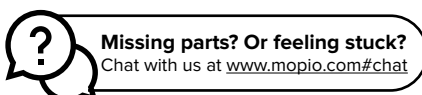
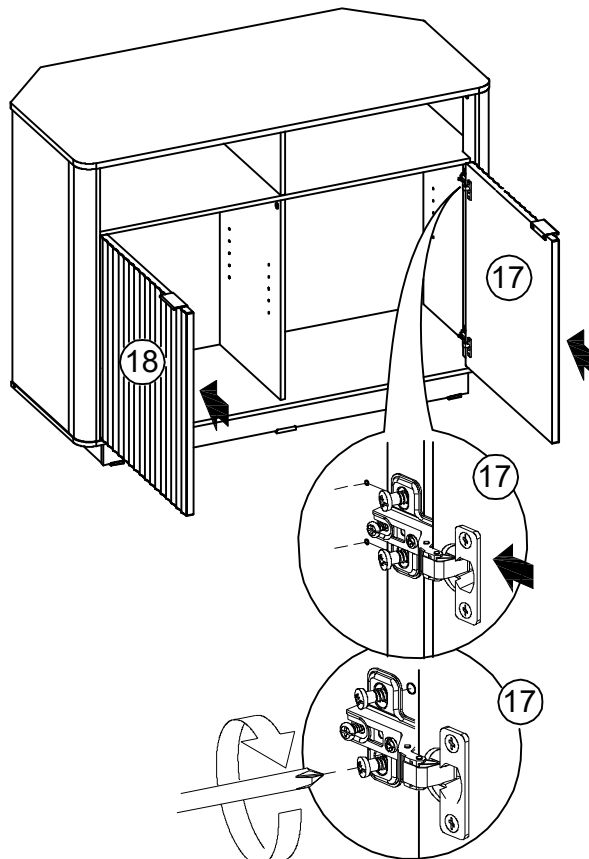

Step 21

To adjust the door to the front and back direction, loosen the back screw as shown on the illustration. Adjust the door to the front or back direction and re-tighten the screw.

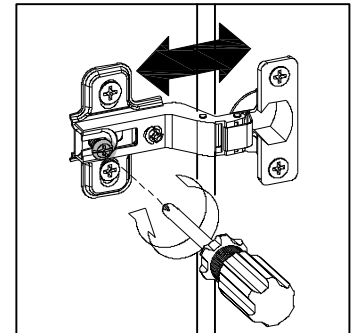
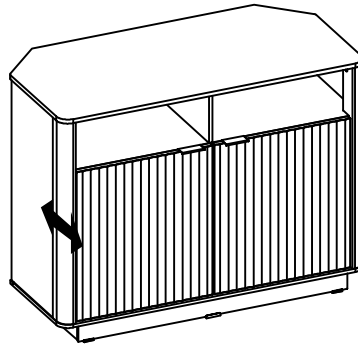

To adjust the door to the up and down direction, loosen 2 screws on mounting plate as shown on the illustration. You may need to loosen 2 hinges at the same time to perform this adjustment. Adjust the door to the up and down direction and re-tighten the screw.

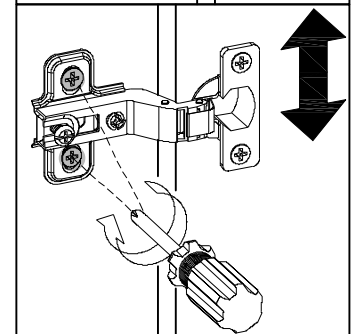
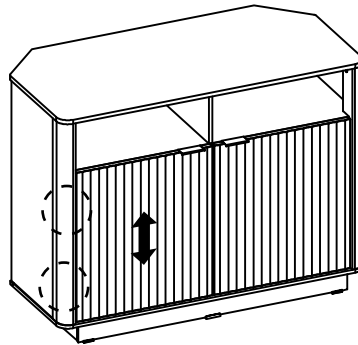

To adjust the door to the side direction, simply loosen or tighten the front screw as shown on the illustration.

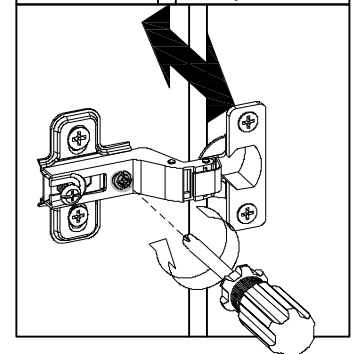
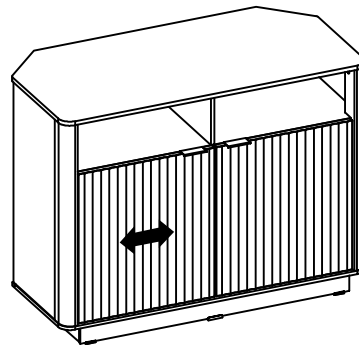

Step 22

Insert Shelf Pins (J) onto Side and Divider Panels in the desired positions.

Place Shelves (8) on the Shelf Pins (J).

Peel Bumper (R) and stick on the backside of handle as shown on the illustration.

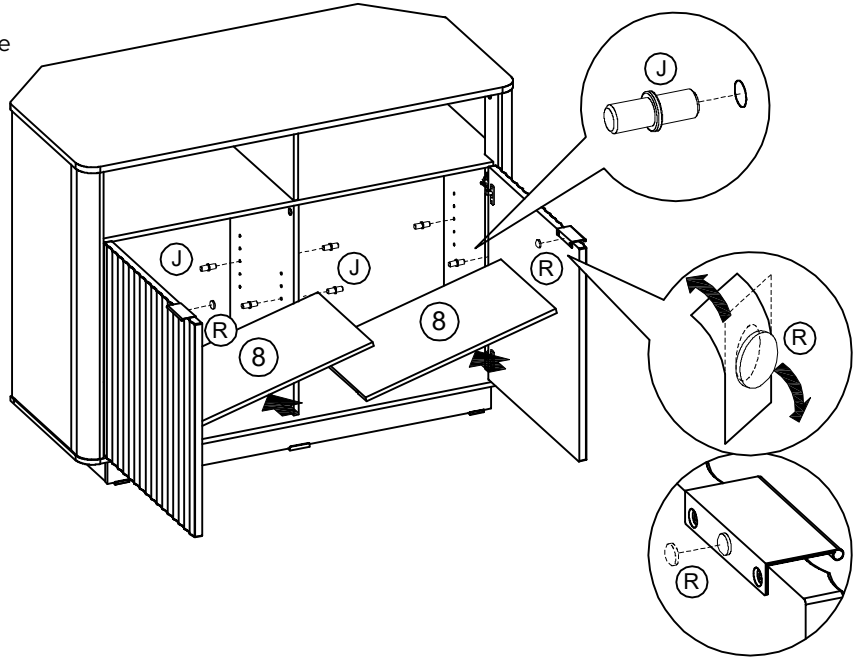

Step 23

Check if the floor is uneven.

If necessary, the center pad can be removed.

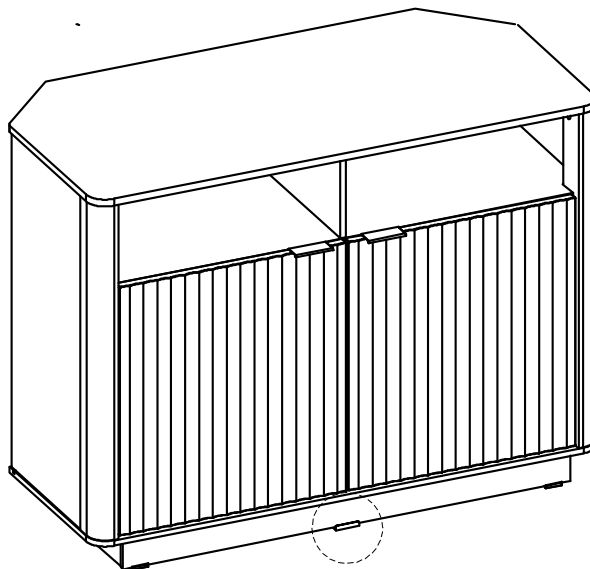

Missing parts? Or feeling stuck?
Chat with us at www.mopio.com/#chat



Watch demo video at:
<https://bit.ly/39Rn29P>

Step 24

Anti-tip Kit

To prevent injury and property damage from unexpected tipping of furniture, we highly recommend installation of the anti-tip kit included with this product.

Check periodically the screw and change the screw position if it start to lose.

Fasten Wall Tipping (N) to Top Panel with Screws (O). With help, move the product into position.

Mark fixing hole on wall and remove product. Where necessary, drill holes and mount hardware.

Reposition product and fix using hardware recommended.

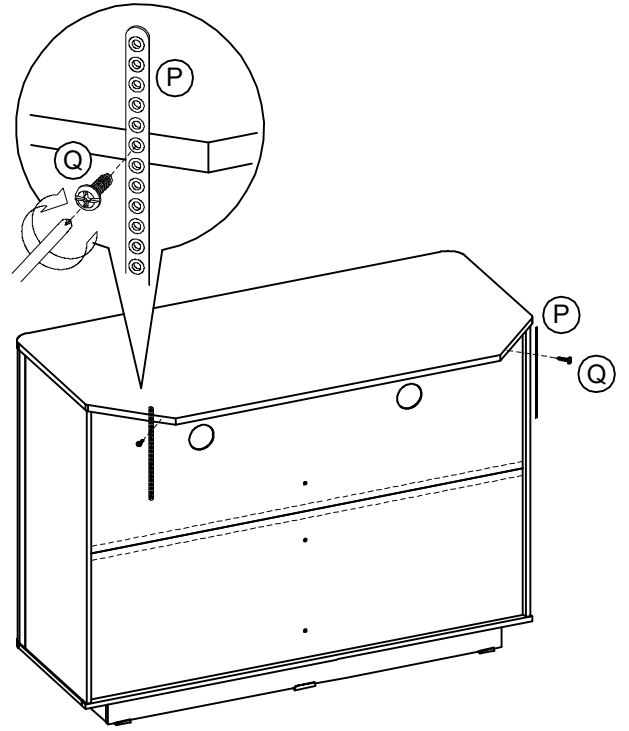

Please seek professional advice if unsure of wall constructions.

Properly affixing furniture to your wall will depend on the wall material: concrete, drywall, masonry, or wood will require the appropriate hardware.

Wall anchor and wall screw is not provided, please source the right wall anchor and wall screw according to the wall type.

Please consult with your local hardware store to ensure you are using the correct



This anti-tip kit is not a substitute for proper adult supervision. This anti-tip kit may provide protection against tipping furniture.

Teach and do not allow children to climb on furniture or drawers. Always keep the heavy load at the bottom of the drawer. Do not put toys or objects on the top of dresser that can attract children to climb.

By installing anti-tip kit, you acknowledge that you are fully aware of the safety requirement and accept to adhere to it. Illustrations in this guide are for reference only and may be slightly different from the actual object.

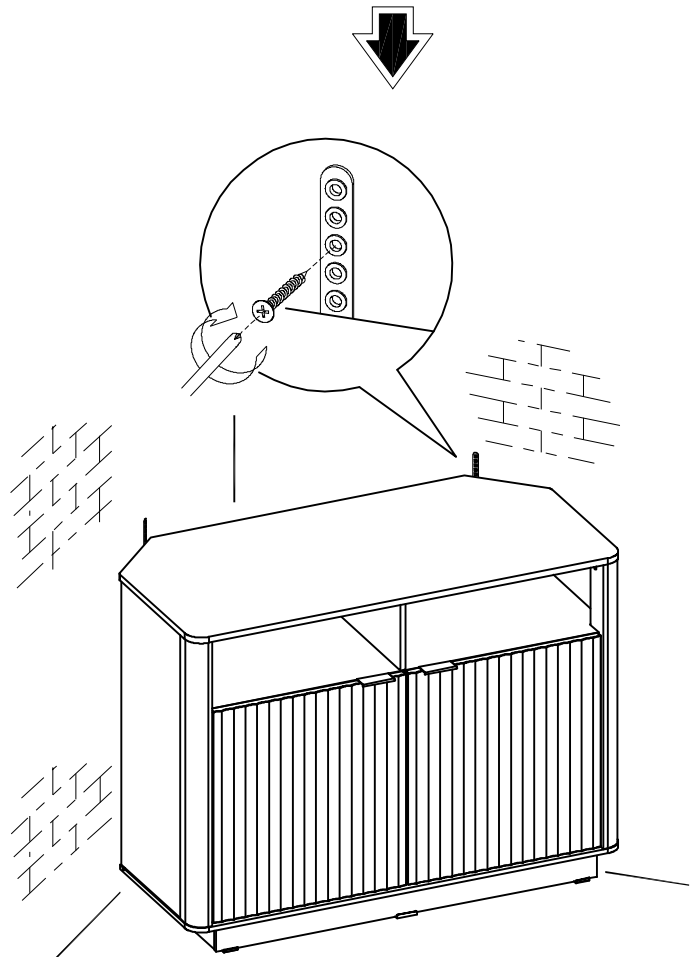

P



x2

Q



x2



Missing parts? Or feeling stuck?
Chat with us at www.mopio.com#chat



Watch demo video at:
<https://bit.ly/39Rn29P>

Finished!

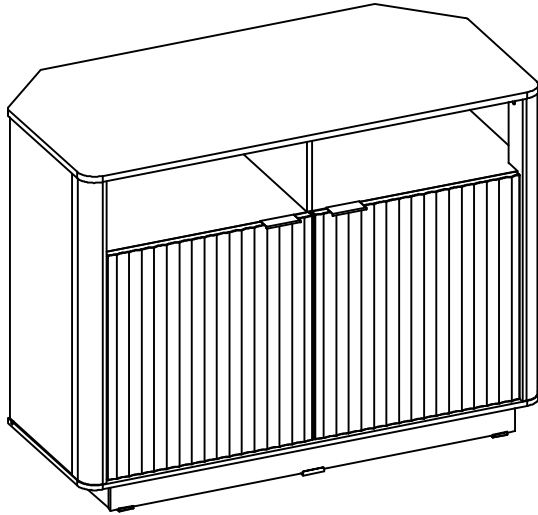

Congratulations, you have made it through the assembly process! We're almost there! ☆

Please perform following checks to ensure assembly is properly done.

- Ensure all legs frame are fully tightened, please refer to Step 12.
- If the door's gap is misaligned, please refer to Step 21. Please ensure the box is square.
- if the product is imbalanced, please refer to Step 21 & 23. Please check if the floor is uneven.

Move your Mopio product carefully, with 2 people lifting it to the preferred location. Clean the product with a dry cloth. You are all set!

Enjoy your fresh and updated living space thanks to the addition of your new Mopio product!

Care

Instructions

Your furniture, if treated with respect and love, will last you a long time. Each piece requires light maintenance to maximize its longevity.

Few quick tips before using this product:

1. Recommended weight limit for the top is 50 lbs and 15 lbs for each of the shelf compartment.
2. Avoid uneven weight distribution for long time as it may cause damage to the product shape.
3. Drawers might not slide smoothly when dresser is overloaded by weight.
4. Check and tighten the camlock and screw periodically as it may loose over the time.
5. Check anti tipping screw periodically, change the screw position if it start to lose.

How to take care of it?

1. Avoid direct sunlight or use curtains or blinds to limit the sun exposure to the product.
2. Clean the product regularly with a dry, soft cloth.
3. Avoid using abrasive or liquid cleanser.
4. Avoid placing hot objects onto the top surface.
5. Spillage may damage the surface. Clean immediately with a dry cloth.
6. We recommend using placemats or coasters underneath glasses, cups, bowls or plates to prevent scratches to the table surface.

Follow the care instructions and look after your furniture, in return, your furniture will look after you.

We hope to see you soon!

Frequently Asked Questions

1. What should I do if my product received is incomplete?

Mopio products are flat packed and come in separate boxes. Once your order has dispatched and been sent with Fedex, you will receive an email with tracking information. Please note that Fedex may deliver your boxes in separate deliveries. Kindly follow the tracking information, allowing all boxes to be received before starting assembly. If you need further assistance on deliveries tracking, feel free to reach out to us at www.mopio.com#chat or help@mopio.com.

2. What should I do if my shipment is damaged or products received are defective?

We're sorry to hear that! Please email us at help@mopio.com or chat with us at www.mopio.com#chat and provide a detailed description of the damage, as well as photos (or videos, where appropriate) showing the damage. We will do our best to resolve the issue as soon as possible.

3. Can replacement parts be ordered?

Yes. Simply write to our customer service team at help@mopio.com or chat with us at www.mopio.com#chat, let us know your order ID and we will be happy to assist further.

4. Who do I contact for repair queries?

You may write to us at help@mopio.com specifying your queries and we will be able to assist you further.

5. What warranty do you offer for your products?

You'll just need to submit your warranty registration upon receiving product at www.mopio.com/warranty/register and it comes with one year warranty period. You can print a copy of your order from Order Details in Amazon and upload it as your proof of purchase. More details can be found in **Warranty section**.

6. How do I claim my warranty?

Easy! Just email us at help@mopio.com and provide a detailed description of the fault as well as photos.

7. What should I do if I want to return the product?

We offer 30-day return policy upon product received. To initiate a return request, please message us through Amazon or contact our customer service team at help@mopio.com or www.mopio.com#chat with your reason of returning so we can facilitate the request and assist you further. For more details on the return policy, please refer to **Return section**.

Warranty & Return

1 YEAR LIMITED WARRANTY STATEMENT FOR MANUFACTURING DEFECTS

Please read this limited warranty carefully. To maintain your warranty, you will need to comply with the conditions stated here. This warranty is for manufacturing defects only and does not cover damages as a result of misuse.

1. Please be sure to register your product at www.mopio.com/warranty/register to receive up to date warranty and product information.
2. Your new product comes with 1-year warranty against manufacturing defects. The warranty starts on the date of purchase. No warranty will be honoured without an original sales receipt. The warranty and financial responsibility of the manufacturer only applies to the products itself.
3. Manufacturing defects include circumstances where the product has broken under normal use and no longer provides proper support. In the event you encounter a manufacturing defect, please stop using this product immediately and contact customer service.
4. This warranty applies only when the product has been properly used by consumers who purchased the product from authorized channels as a new product. Proper use means using the product on a level surface where all legs touch the floor with an equal distribution of weight. Proper use also means that the product was not abused by the consumer, as defined by the manufacturer. This warranty does not constitute agreement to replace other parts.
5. If the product fails due to manufacturing defects, the manufacturer will repair or replace at its discretion and reserves the right to substitute comparable materials or models and does not guarantee that the replacement part will match existing pieces.
6. In the event the product needs to be inspected by the manufacturer to determine a warranty claim, the transportation cost or removal cost is borne by the consumer.

MOPIO'S 30-DAY RETURN POLICY

We believe you will be thrilled with your purchase from Mopio. That's because we go out of our way to ensure that products are designed and built to be just what you need. We understand, however, that sometimes a product may not be what you expected it to be. In that event, we invite you to review the following terms related to returning a product.

The Return

Returns are to be made within 30 days of the date you received the product. To initiate return request, please message us or contact our customer service team at help@mopio.com or www.mopio.com#chat with your reason of returning so we can facilitate the request and issue return authorization to you. Please note the policy is subject to the conditions below:

1. Only undamaged items in original packaging will be accepted under the Returns Policy. Any items that are not returned to us in the original packaging and/or in original condition will incur an additional handling fee (deducted from your refund). It is your responsibility to package the item sufficiently to avoid damage in transit back to us. We encourage customers to photograph the items scheduled for return and the condition of the packaging before handing over to the delivery company.
2. We will not refund a product that you have bought and received where, in our reasonable opinion, the product has: become of unacceptable quality due to fair wear and tear; misuse; using it in an abnormal way; or failure to take reasonable care.
3. We will not be able to offer standard return policy after 30-day timeframe has passed. However, our customer service team is always an email away if you require further assistance with your Mopio products.

The Refund

We will assist you to complete the return process. We will perform standard inspection upon your return is received and will send you a message to acknowledge the return if item is presenting in original condition with original packaging.

You will be refunded the full amount less return shipping cost. Please note that while shipping charges on original deliveries are subsidized, on returns the full shipping amount paid by Mopio to the delivery partner will be deducted from your refund. **All refunds will take 2 business days to process upon return acknowledgement from us, however actual fund reversal date will depend on your card company's own processing schedule.**

Kindly note, in the event of returning a defective or damaged item, **we will however absorb the shipping charges and ensure your return/exchange experience is hassle free.**

The Exchange

We put quality as one of our top priorities – we work with experienced manufacturers and have every piece of Mopio product going through strict quality control process. We want to make sure your Mopio product reaches you safe and sound, however we are happy to do an exchange in case you receive a defective or damaged product due to any unforeseen hiccups throughout the journey. Please message us or email us at help@mopio.com with proof of defect or damage, our customer service will evaluate the exchange request, and assist you throughout the process accordingly.