

NORWIN LADDER DESK

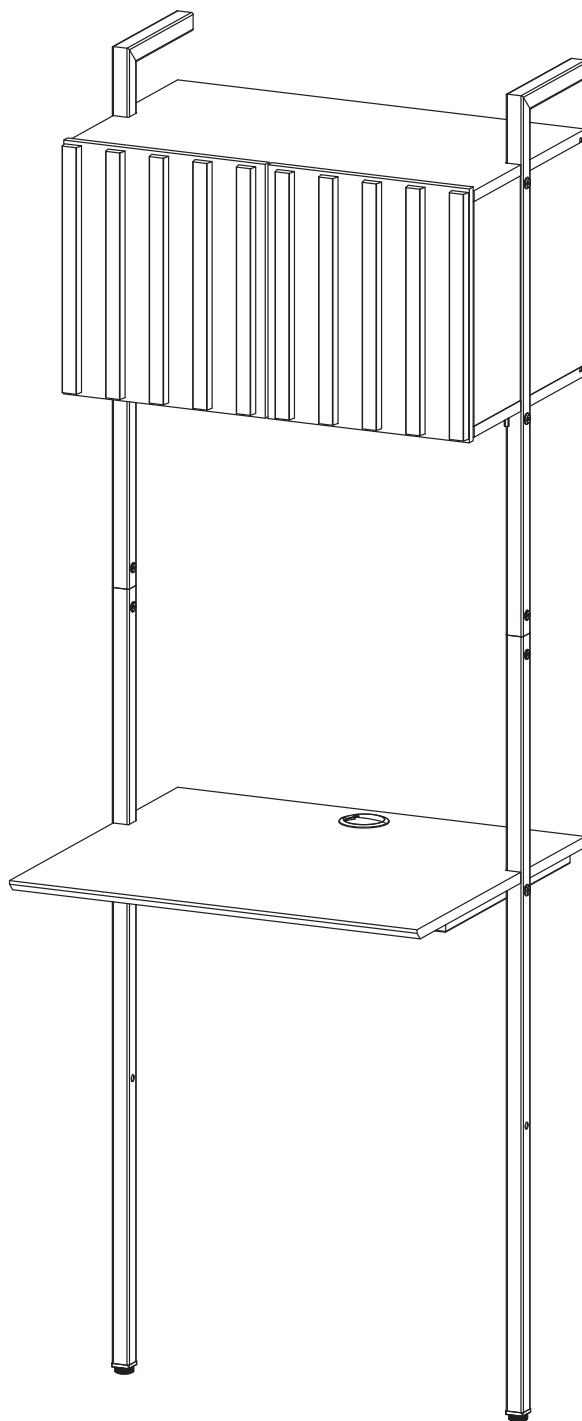

ASSEMBLY INSTRUCTIONS

mopio[®]

Join Mopio Club and enjoy your 1-Year Warranty

We've got more for you. Be part of **Mopio Club** and enjoy:

- Privileged Customer Care
- 10% Off Your Next Purchase (no min spend)
- 1-Year Free Warranty
- Early Access To Upcoming Launches

Scan the QR code or go to the link to find out more:
www.mopio.com/club



Chat With Us!

For any enquiries or issues regarding your purchase, chat with us
at www.mopio.com/chat.

Or connect with us through other channels:

✉ help@mopio.com

📘 @mopioinc

🌐 www.mopio.com

Before you start...

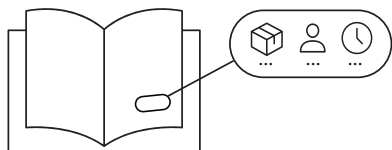

Ensure you have received all cartons and familiarize yourself with the workload. Make sure there are enough helping hands to assist you, and that you have allocated the time required to assemble your new product.

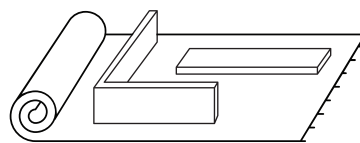

Make sure you have cleared enough space in your home for the assembly. We recommend protecting your floor with a mat or cardboard to avoid scratches during the assembly process.

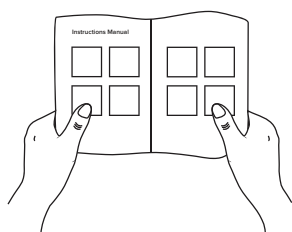

Read instructions carefully and check no parts are missing.

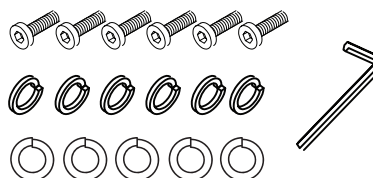

Lay out all hardware on a soft surface so you can easily identify them.

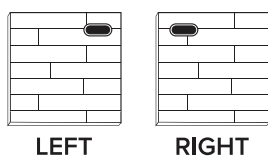

Carefully identify all components in order to differentiate which pieces are left and right.

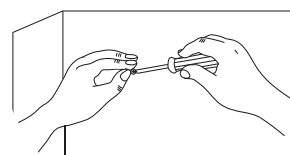

Install your new product carefully following the instructions. Don't skip ahead!

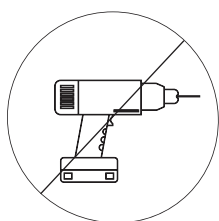

DO NOT over tighten screws or use a drill. It will damage the product.



If you need further assistance with assembling your Mopio product, please chat with us at www.mopio.com#chat.

Parts

 Watch installation demo video at:
<https://bit.ly/3HJVmS9>



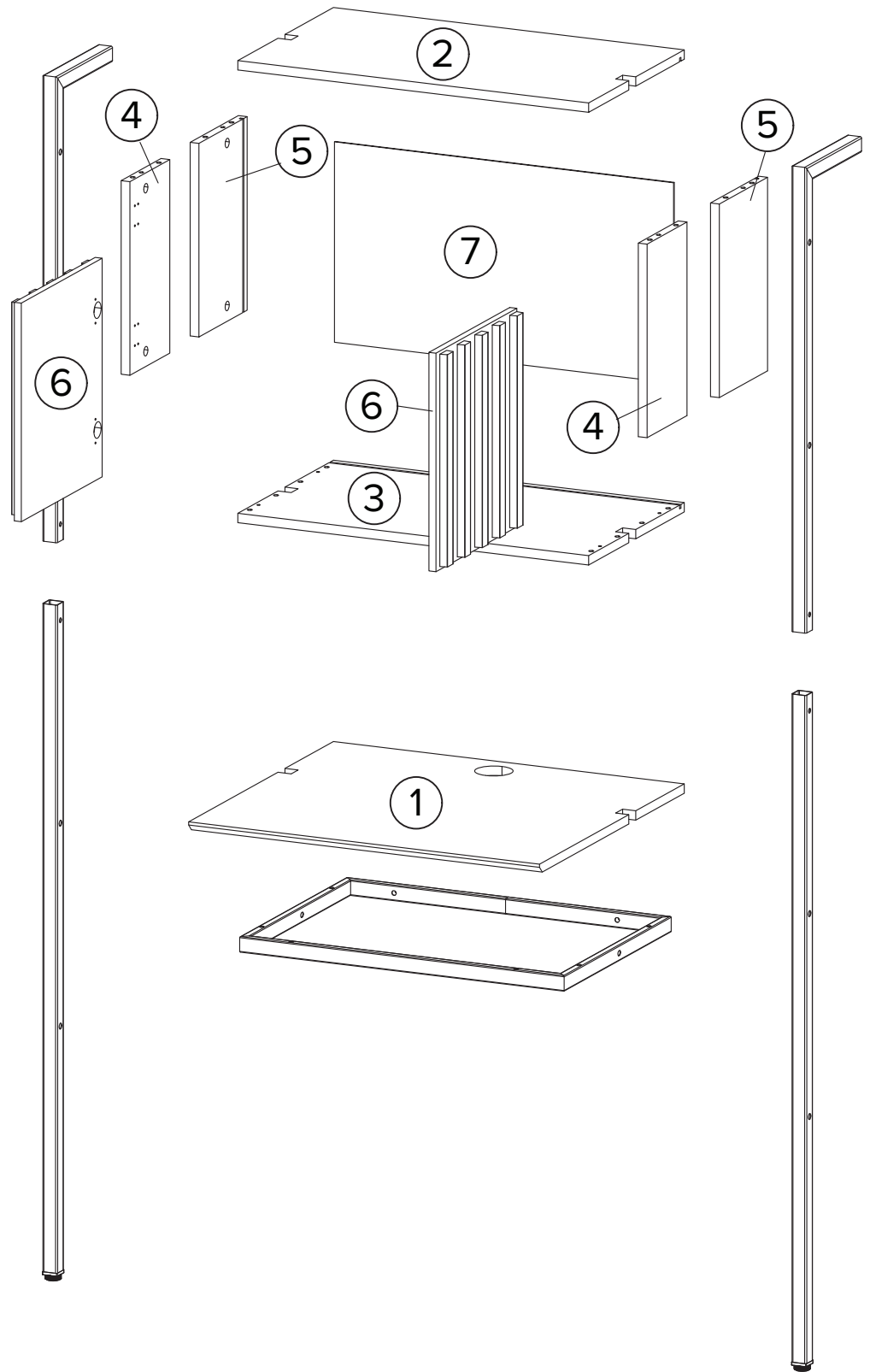







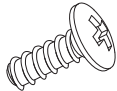
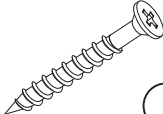

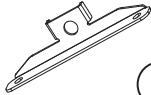
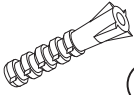
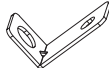
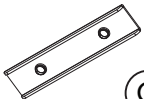
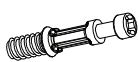
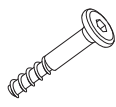
- ① x1
- ② x1
- ③ x1
- ④ x2
- ⑤ x2
- ⑥ x2
- ⑦ x1

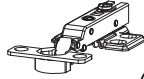
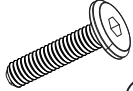
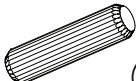



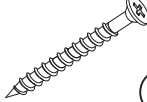
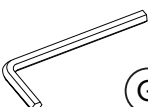
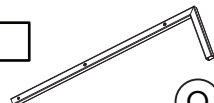

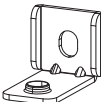
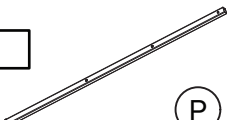

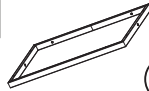

Hardware



Watch installation demo video at:
<https://bit.ly/3HJVmS9>

-  Screw M 4.5 x 12.5 mm **(A) x30**
-  Screw 5.5 x 35 mm **(I) x2**
-  Wedge **(Q) x4**
-  Shelf Bracket **(B) x2**
-  Wall Plug **(J) x4**
-  Plate **(R) x2**
-  Joint Bracket **(C) x4**
-  Cambolt Ø 6 x 35 mm **(K) x8**
-  Screw Ø 6.4 x 35 mm **(S) x6**
-  Screw M 6 x 10 mm **(D) x10**
-  Camlock Ø 15 mm **(L) x8**
-  Hinge **(T) x4**
-  Screw M 6 x 20 mm **(E) x6**
-  Dowel Ø 8 x 30 mm **(M) x16**
-  Screw M 6 x 30 mm **(U) x2**
-  JCN Nut **(F) x8**
-  Hole Cable **(N) x1**
-  Screw 5.5 x 45 mm **(V) x2**
-  Allen Key **(G) x2**
-  Top Leg Frame **(O) x2**
-  Screw Cap Ø 15 mm **(W) x8**
-  Wall Bracket **(H) x2**
-  Bottom Leg Frame **(P) x2**
-  Screw M 3.5 x 15.5 mm **(X) x4**
-  Iron Frame **(Y) x1**

-  This product will require 1hr for assembly. We hope that you will enjoy the assembly process and hang in there!
-  There are inner box(es) that include components required to complete this assembly.
-  Please do not completely tighten all the hardware, until each assembly step is complete.
-  Before discarding the packaging, please use the checklist to ensure that you have all the parts required to assemble your product. Please kindly note you will need the original package if you want to return the product later.
-  If parts are missing or damaged, we will gladly ship your replacements parts free of charge. Please contact us at help@mopio.com or chat with us at www.mopio.com#chat.

 **x1**
 **x2**
 **60 mins**

Pre-Assembly

Ensure the Leveler underneath each Bottom Leg Frame (P) is tightened before proceeding with the assembly.

Ensure your floor is properly protected.

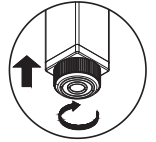

Step 1

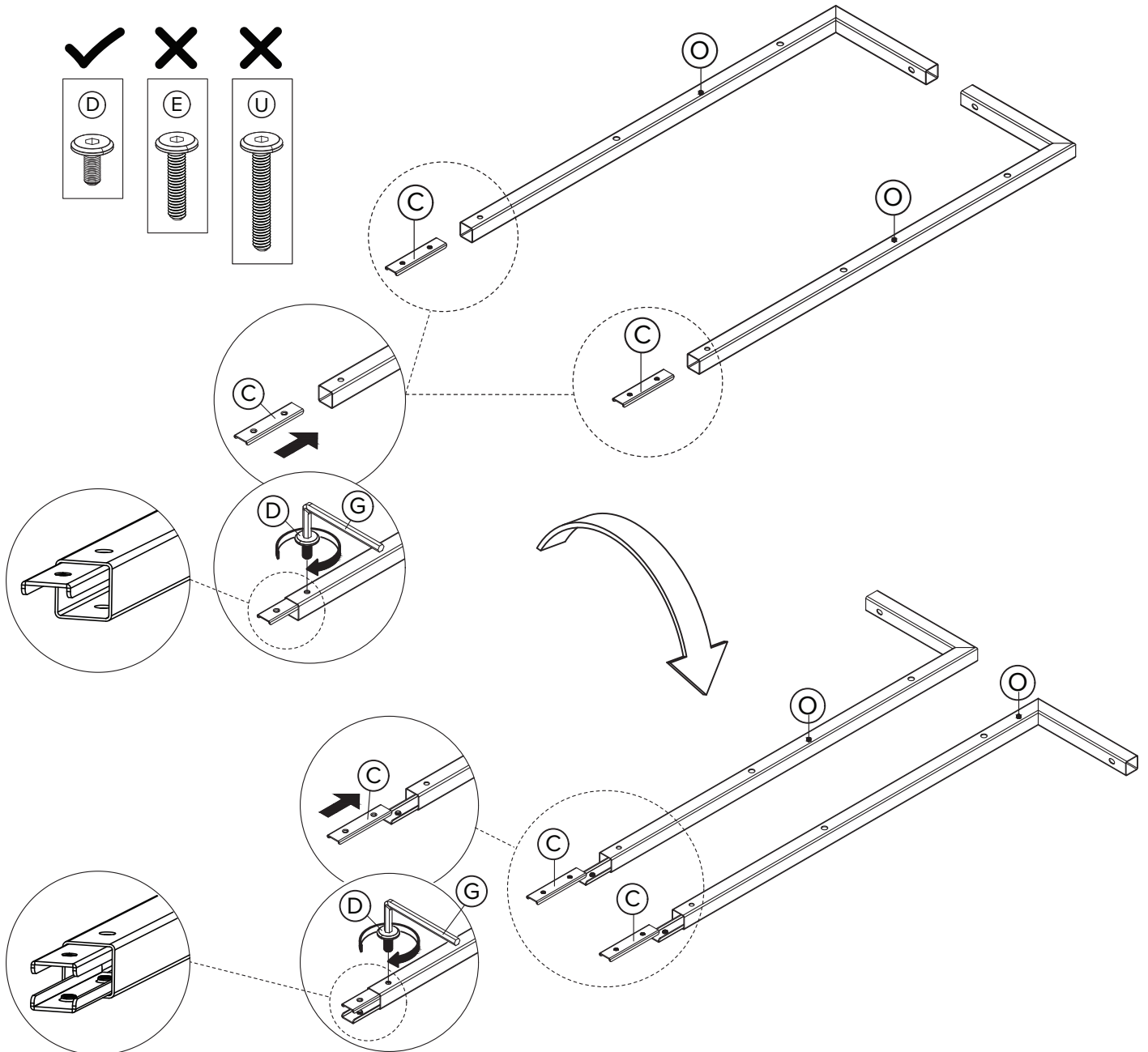

Missing parts? Or feeling stuck?
Chat with us at www.mopio.com#chat

Watch demo video at:
<https://bit.ly/3HJVmS9>

Step 2

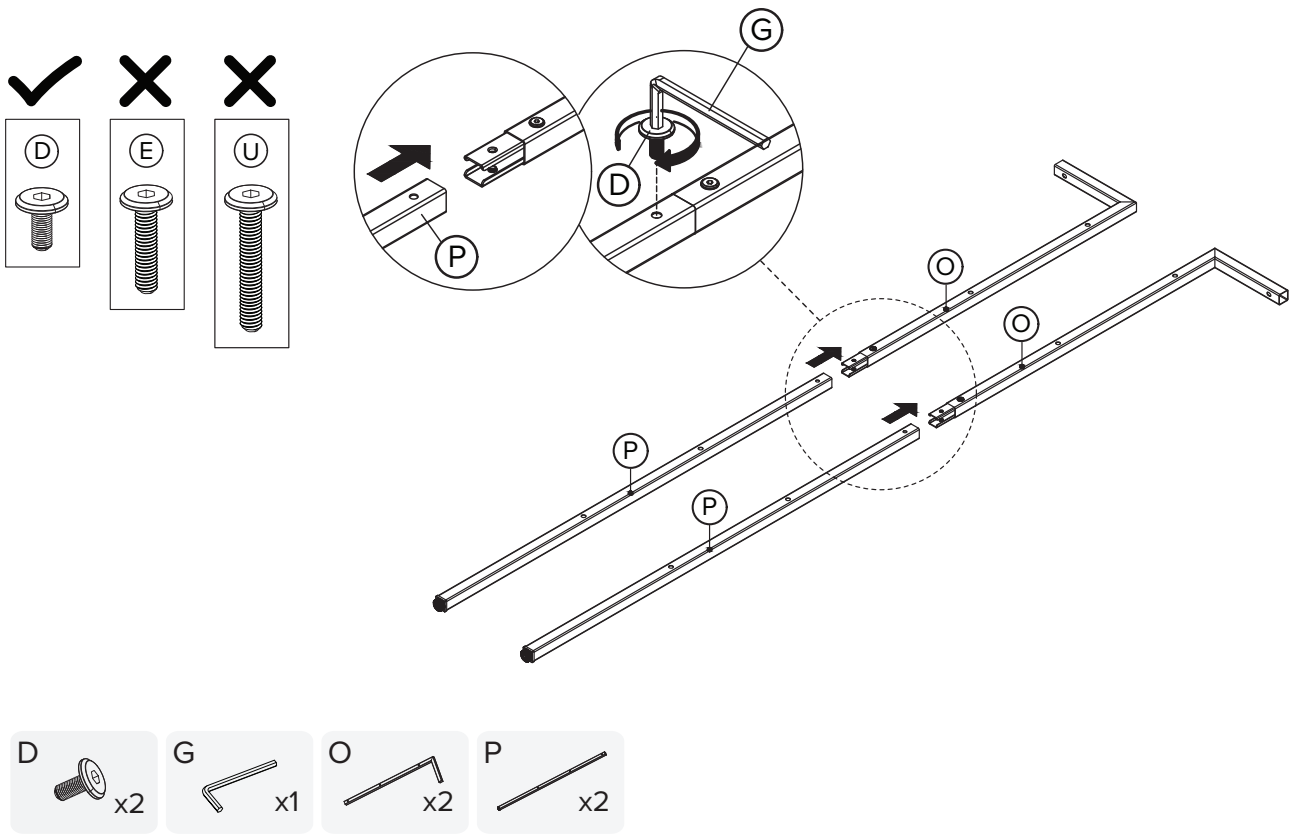

Step 3

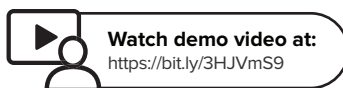
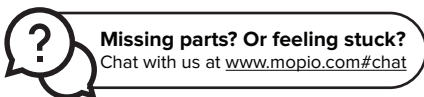
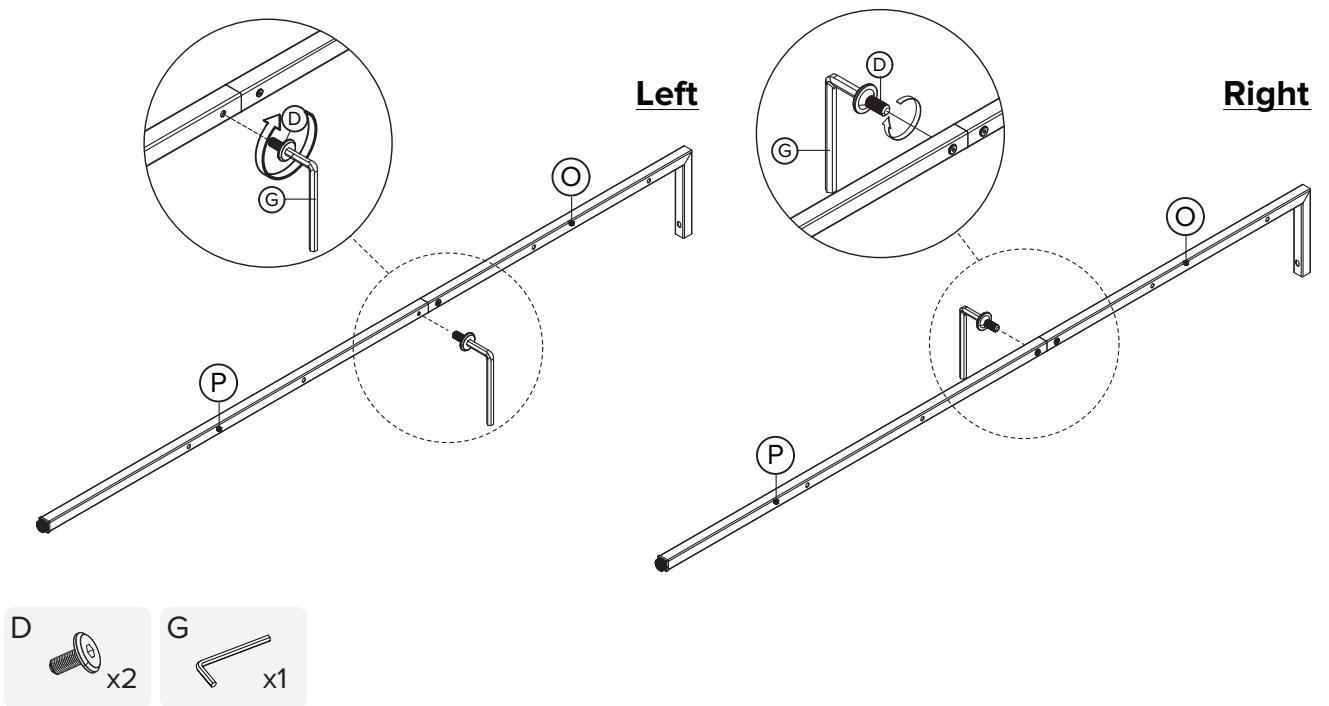

Step 4

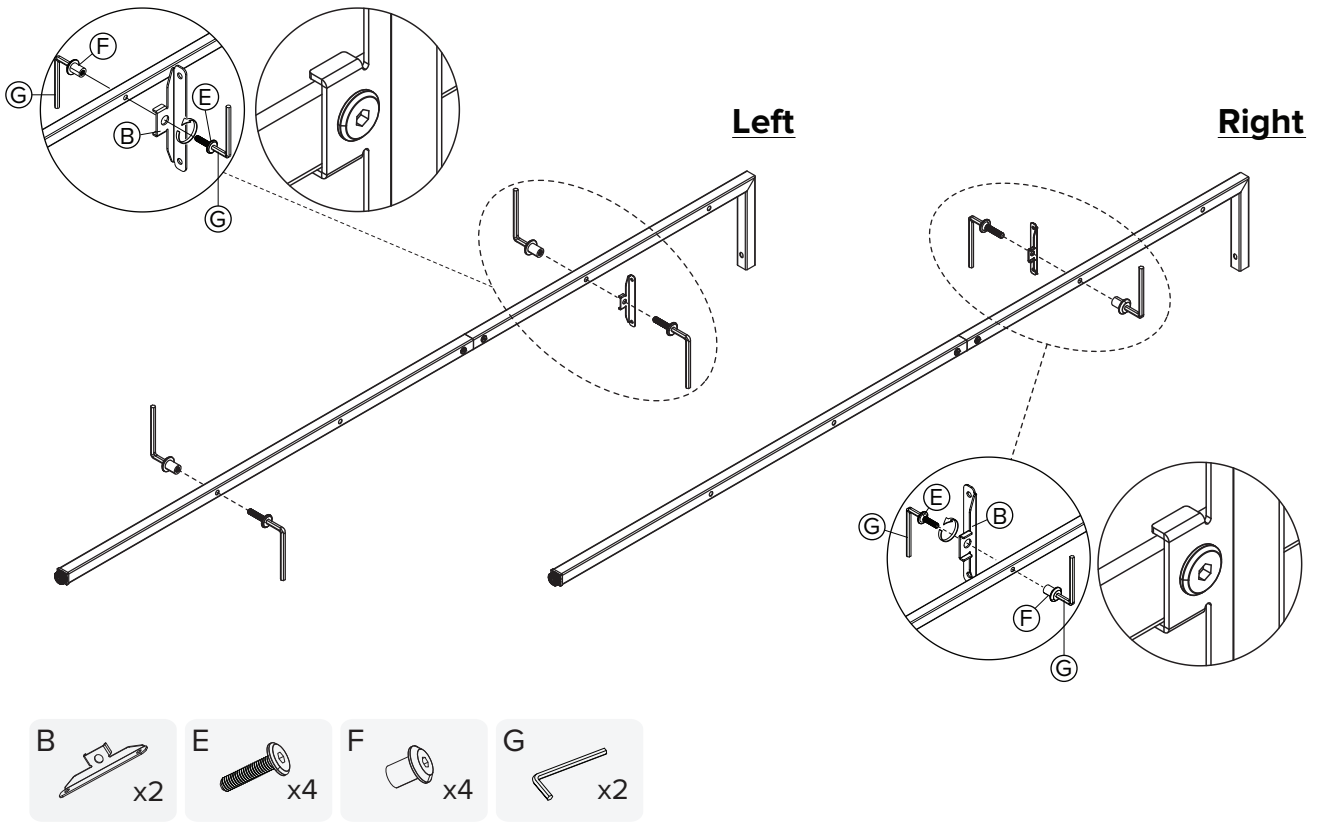

Step 5

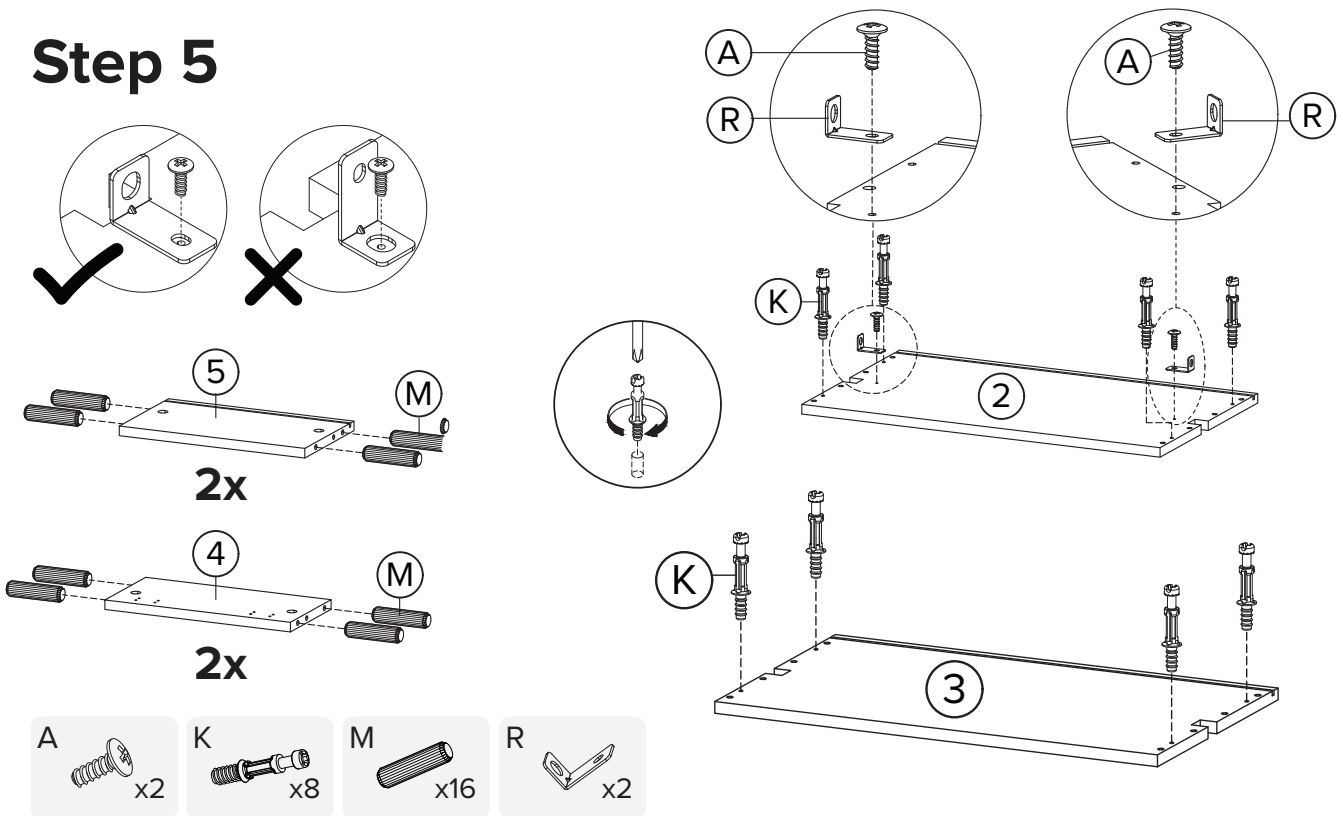

? Missing parts? Or feeling stuck?
Chat with us at www.mopio.com#chat

▶ Watch demo video at:
<https://bit.ly/3HJVmS9>

Step 6

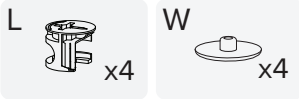
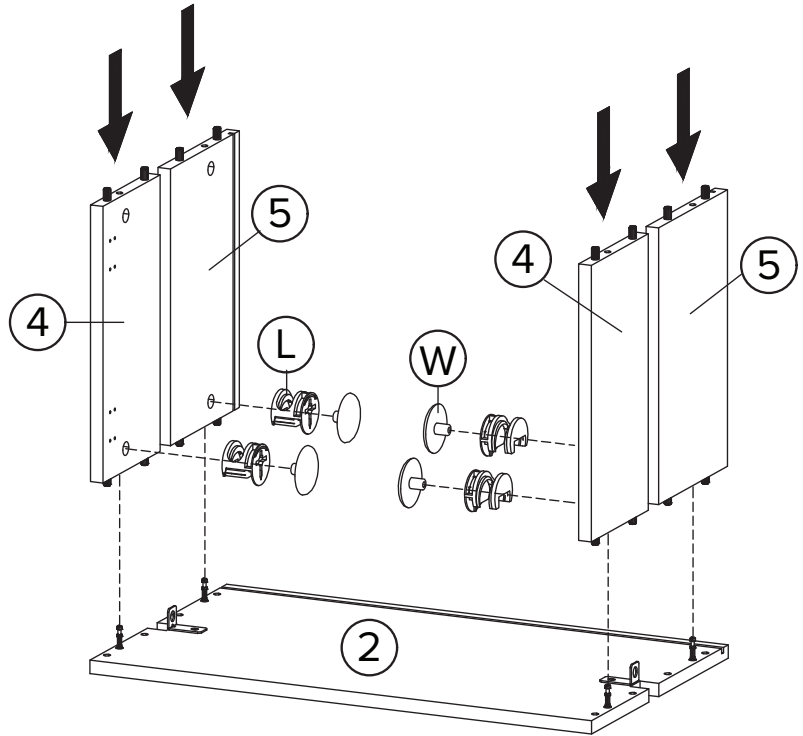
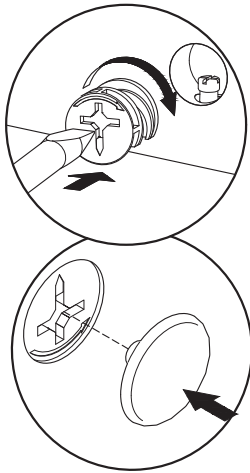

Step 7

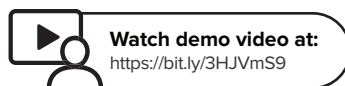
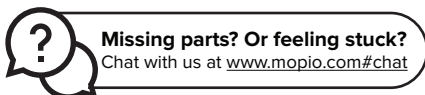
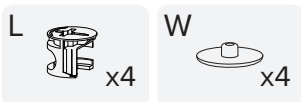
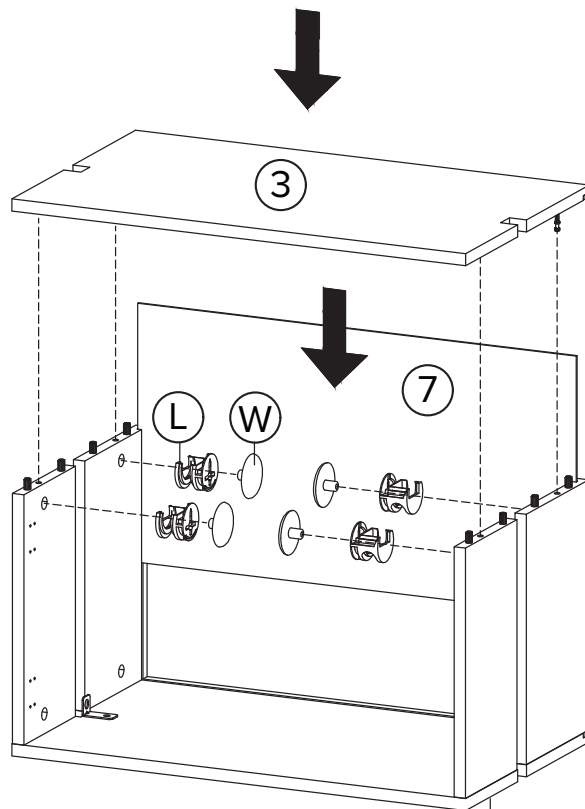
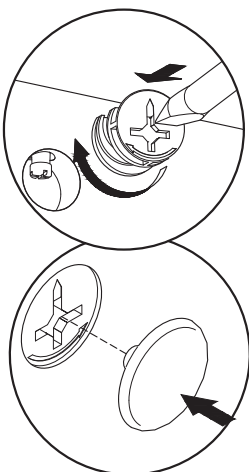

Step 8

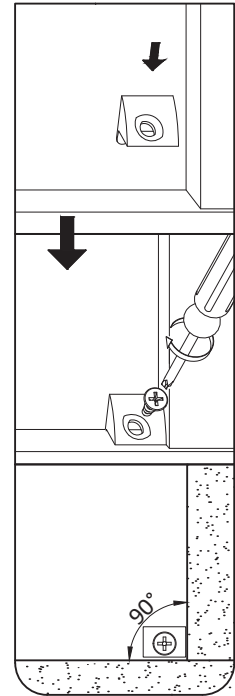
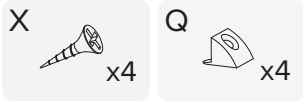
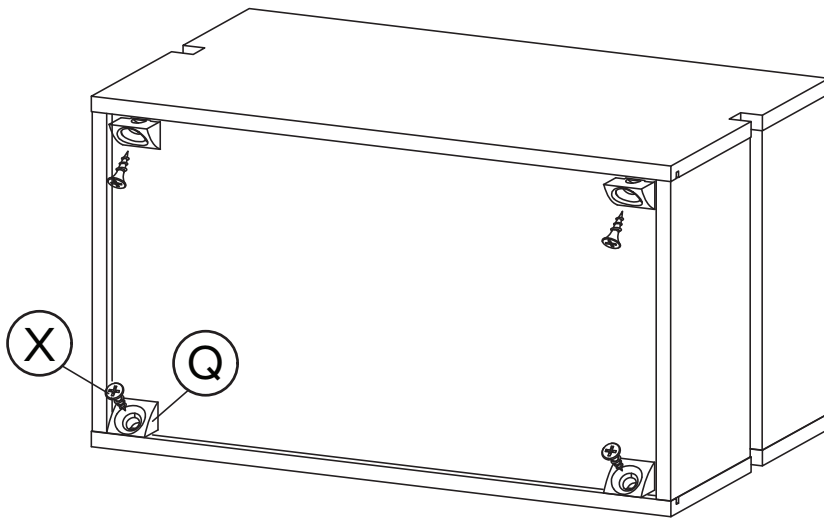

Step 9

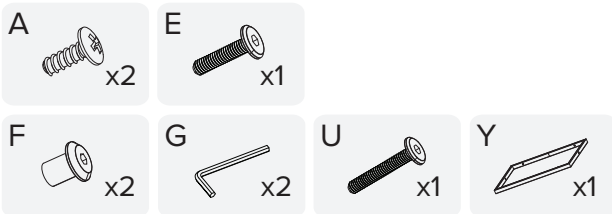
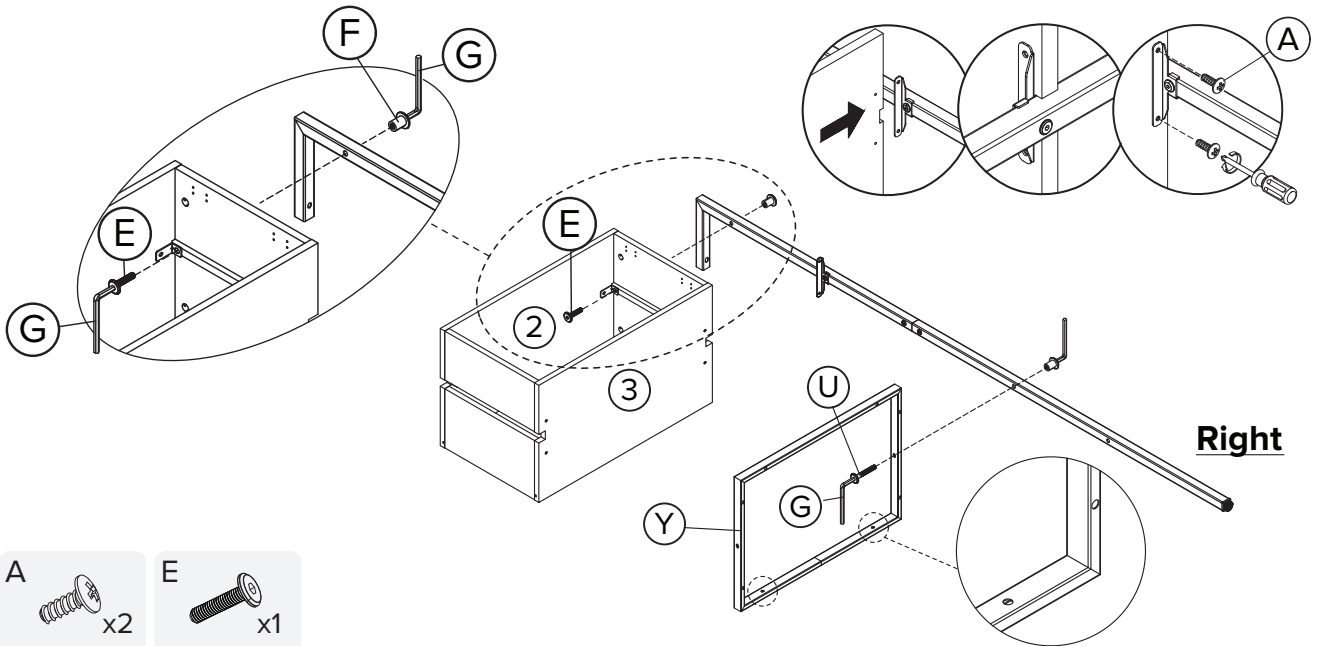
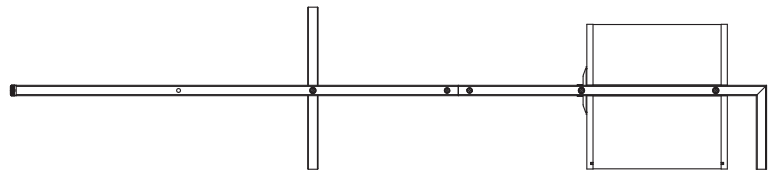

Missing parts? Or feeling stuck?
 Chat with us at www.mopio.com/#chat

Watch demo video at:
<https://bit.ly/3HJVmS9>

Step 10

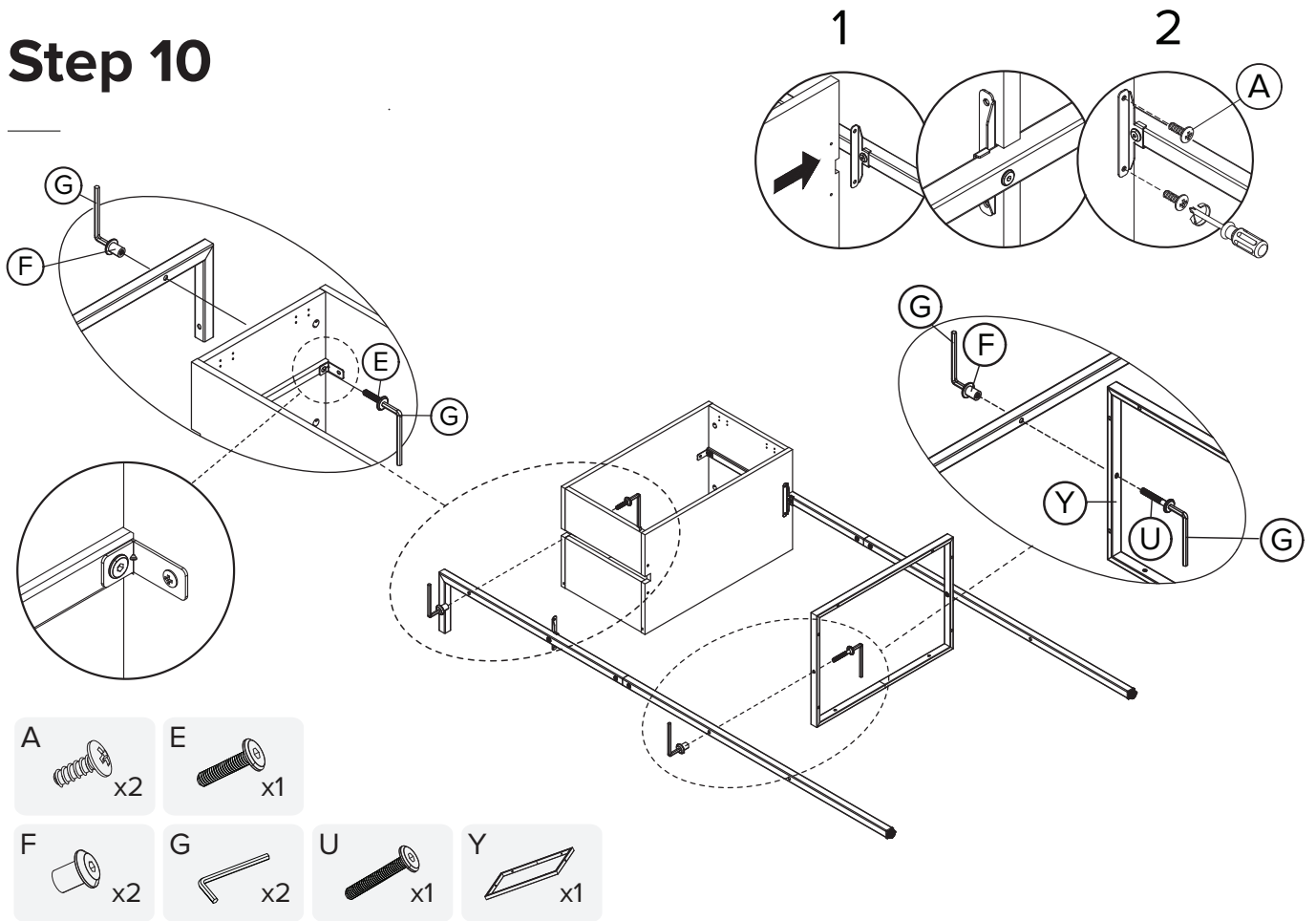

If you are installing this product beside other items in the NORWIN LADDER collection, please ensure to align the top of the legs and the shelves.

You may need to adjust the measurement in Step 11 according to the new alignment.

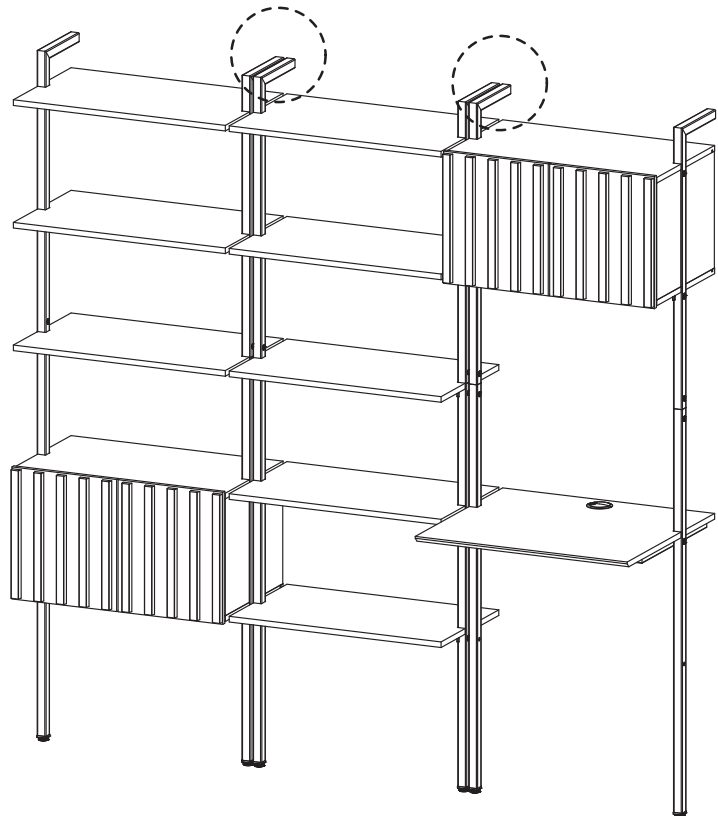
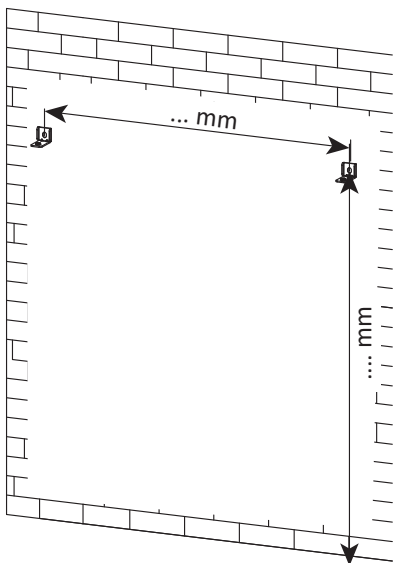

? **Missing parts? Or feeling stuck?**
Chat with us at www.mopio.com#chat

▶ **Watch demo video at:**
<https://bit.ly/3HJVmS9>

Step 11

Please seek professional advice if unsure of wall constructions.



Properly affixing furniture to your wall will depend on the wall material: concrete, drywall, masonry, or wood will require the appropriate hardware.

Ensure that the screw is attached tightly and properly to the wall.

Loose screws, may cause the product to tip.

Double-check before continuing to the next step

please source the right wall anchor and wall screw according to the wall type. Please consult with your local hardware store to ensure you are using the correct hardware for your wall type.

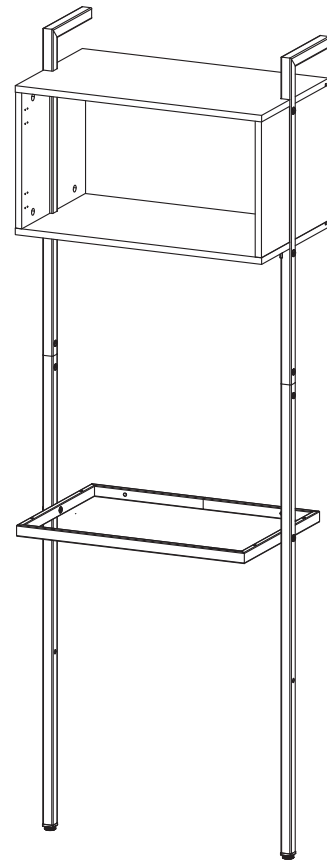

Measure the hole position on the wall.
Check the illustration before making the hole in the wall.

For concrete wall:
Insert Wall Plug (J) using a soft hammer and position Wall Bracket (H) on it.
Install Screw (I) in the center of the hole and tighten.

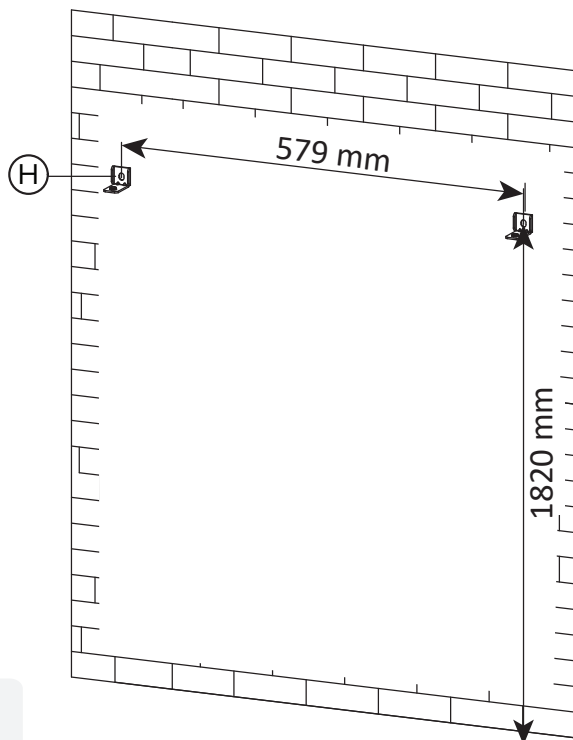

Missing parts? Or feeling stuck?
Chat with us at www.mopio.com/#chat

Watch demo video at:
<https://bit.ly/3HJVmS9>

Step 12

You will require additional helping hands for this step.

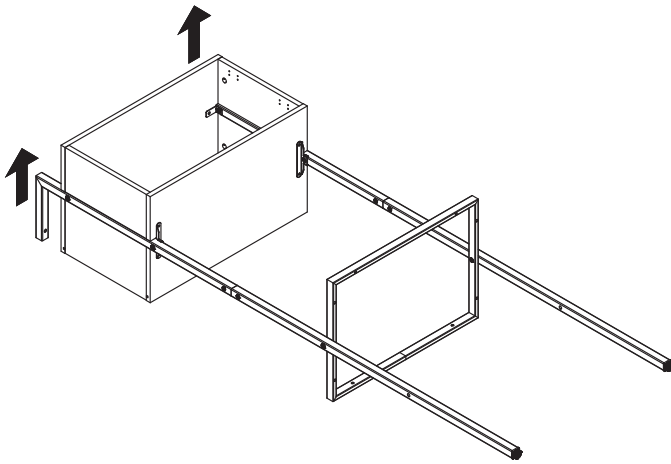

IMPORTANT TIP

Please mind to carefully lift the product upright by doing the following steps :

- 1) Have at least 2 people grab and lift the product by the metal joint in the middle as shown below.
- 2) When rotating to an upright position, please not to use the feet as a pivot point. Lift then carefully place on the floor, before continue to next step.

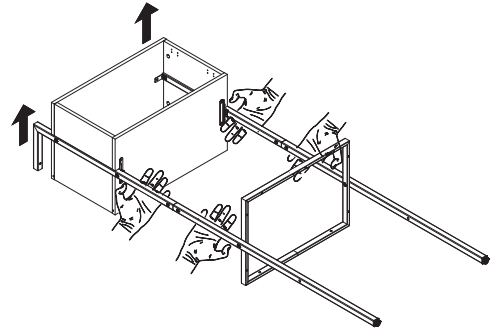

Step 13

You may require additional helping hands for this step.

Slot in the top leg to the Wall Bracket (H),
If the leg is hanging, you can leave it as it will be adjusted on the Step 14.

If the Wall Bracket (L) is too low, untighten screw (I) and adjust the Wall Bracket (L) slightly higher. Retighten the screw (I), refer to Step 11.

Allocate Wall Bracket (L) on the most bottom shelf (1), mark a hole using a pencil.

Remove the Ladder Shelf and place it safely on the floor.

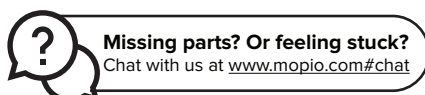
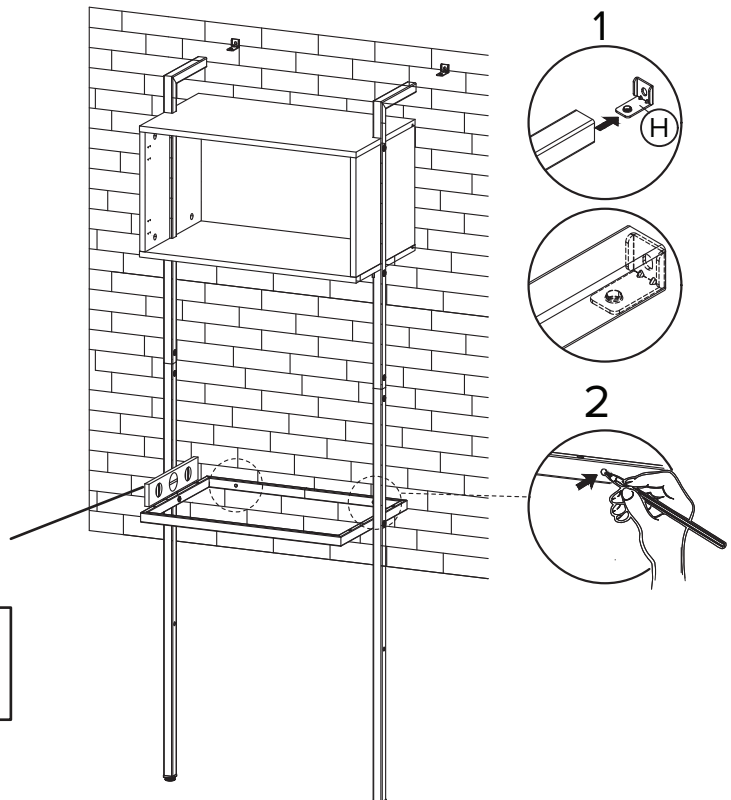
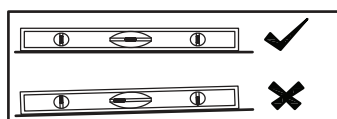
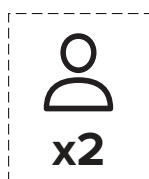

Step 14

Make a hole in the wall on the pencil mark from previous Step 13.

For concrete wall: insert Wall Plug (J) using a soft hammer.

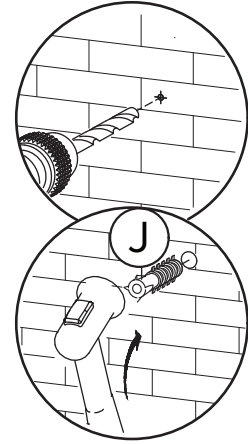
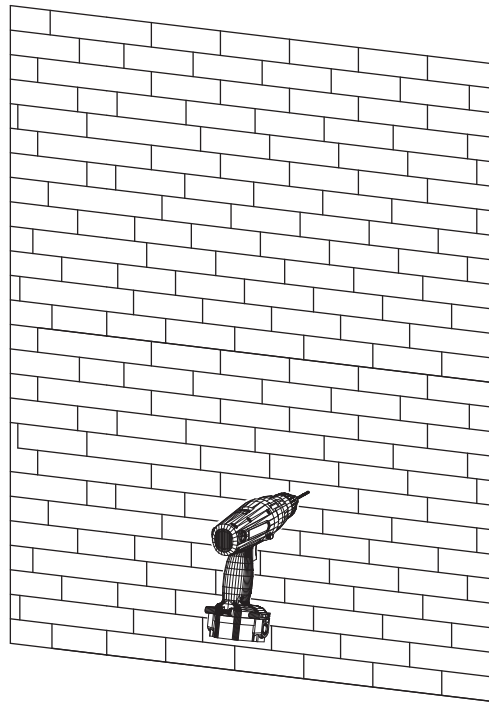

Step 15

Slot in Top Leg Frame (O) to the wall bracket. Tighten the Wall Bracket on the top using Screw (D).

Tighten wall mounting at the bottom using Screw (V).



This anti-tip kit is not a substitute for proper adult supervision. This anti-tip kit may provide protection against tipping furniture.

Tips:

Teach and do not allow children to climb on furniture or drawers. Always keep the heavy load at the bottom of the drawer. Do not put toys or objects on the top that can attract children to climb.

By installing anti-tip kit, you acknowledge that you are fully aware of the safety requirement and accept to adhere to it. Illustrations in this guide are for reference only and may be slightly different from the actual object.

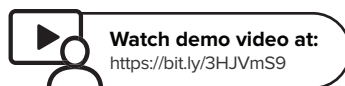
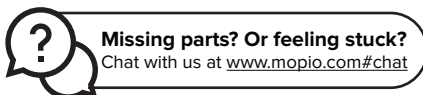
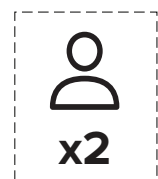
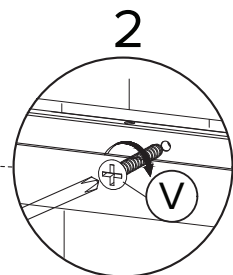
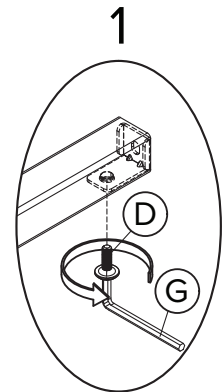
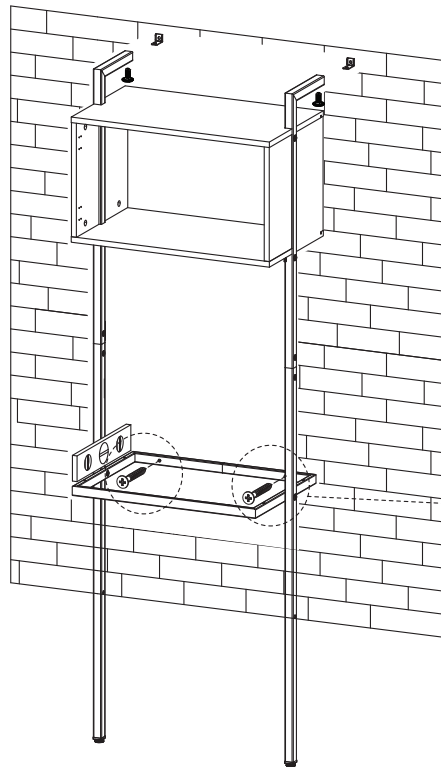

Step 16

Adjust the leg leveler to the floor.

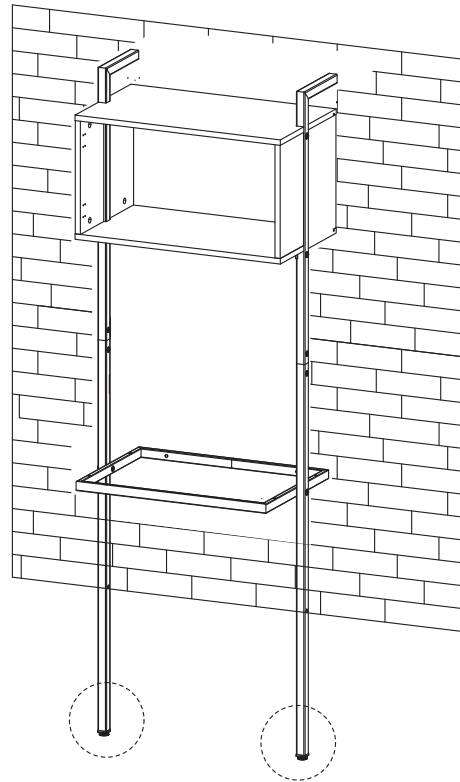
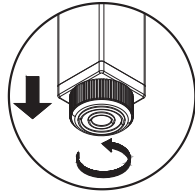

Step 17

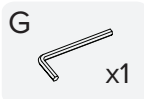
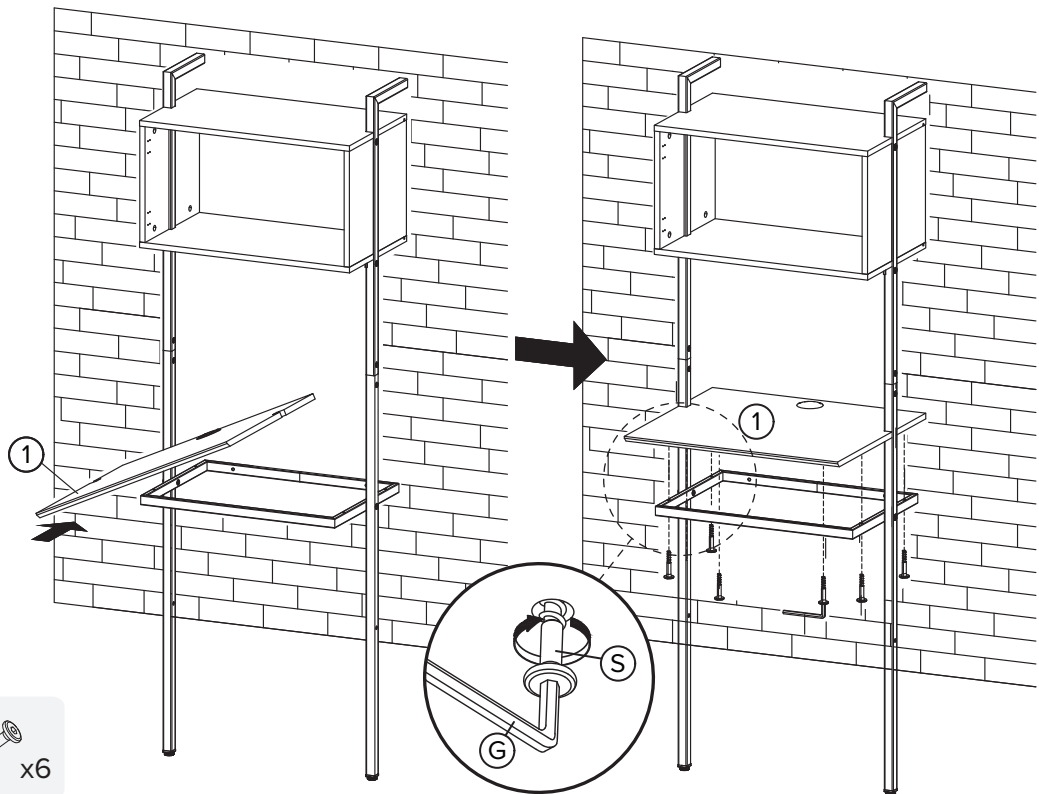

Missing parts? Or feeling stuck?
Chat with us at www.mopio.com/#chat

Watch demo video at:
<https://bit.ly/3HJVmS9>

Step 18

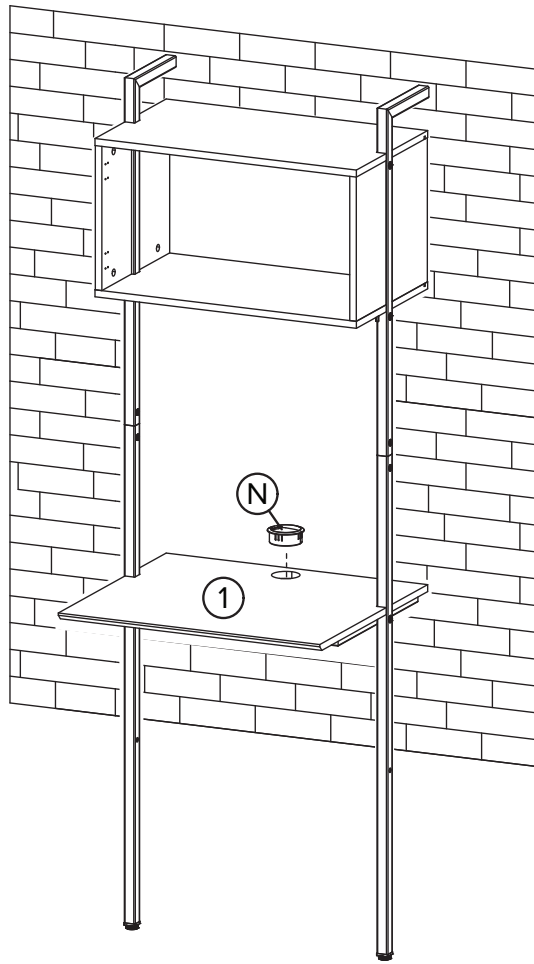

Step 19

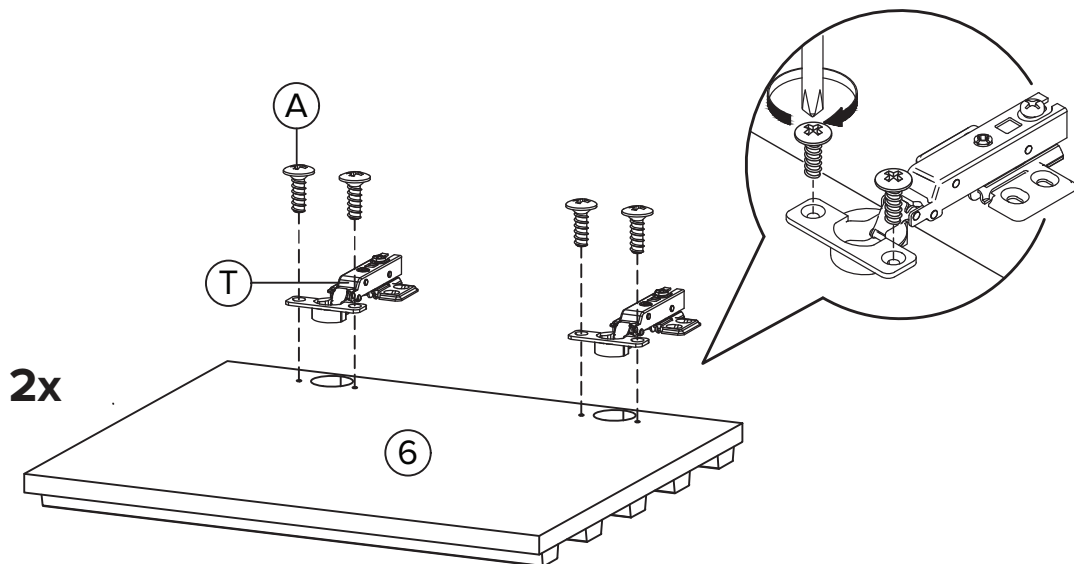

 **Missing parts? Or feeling stuck?**
Chat with us at www.mopio.com#chat

 **Watch demo video at:**
<https://bit.ly/3HJVmS9>

Step 10

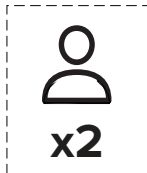
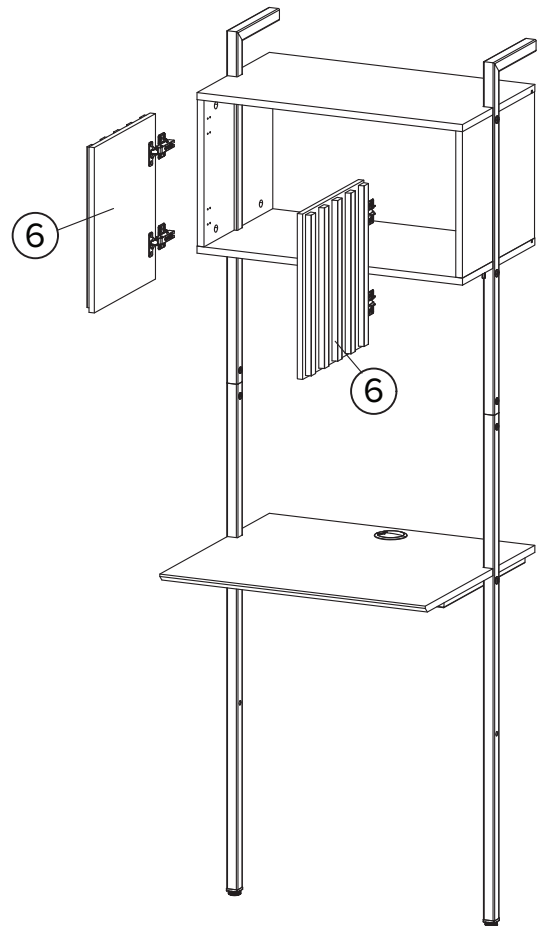
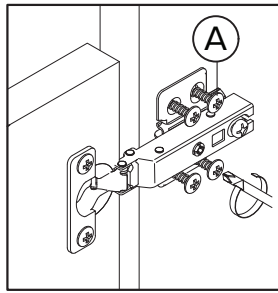
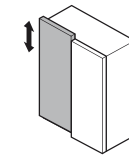
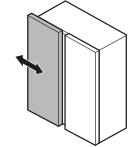
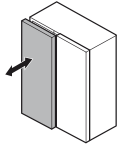
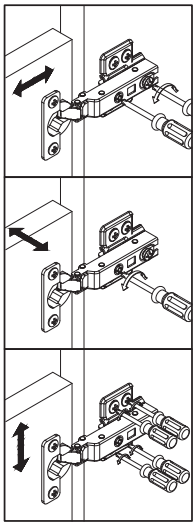

Finished!

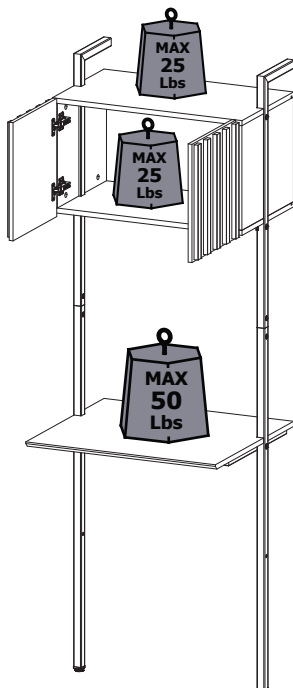

For safety reason, please do not put sharp and heavy objects on the top shelf.

Congratulations, you have made it through the assembly process! We're almost there!

Please perform following checks to ensure assembly is properly done.

- Ensure all shelves, cabinet and desk metal frame are fully tightened, please refer to Step 9- Step 10. Loose screws or wall fixing may cause risk of tipping.
- Ensure the product is fully tightened to the wall before use, please refer to Step 15. Do not use the product if not fully tightened to the wall.
- If product is imbalance, please refer to Step 13 - Step 15.

Clean the product with a dry cloth. You are all set!

Enjoy your fresh and updated living space thanks to the addition of your new Mopio product!

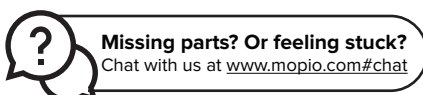

Care

Instructions

Your furniture, if treated with respect and love, will last you a long time. Each piece requires light maintenance to maximize its longevity.

Few quick tips before using this product:

1. Recommended weight limit for the top and inside of cabinet is 25lbs, the desk is 50lbs.
2. Avoid uneven weight distribution for long time as it may cause damage to the product shape.
3. Shelf might be bending if overloaded by weight.
4. Check and tighten the camlock and screw periodically as it may loose over the time.
5. Ensure that the product is well secured to the wall. Please check and tighten any loosen screw

How to take care of it?

1. Avoid direct sunlight or use curtains or blinds to limit the sun exposure to the product.
2. Clean the product regularly with a dry, soft cloth.
3. Avoid using abrasive or liquid cleanser.
4. We recommend always attaching the provided floor protector to the leg ends to protect your floor.
5. Avoid placing hot objects onto the table top surface.
6. Spillage may damage the surface. Clean immediately with a dry cloth.
7. We recommend using placemats or coasters underneath glasses, cups, bowls or plates to prevent scratches to the table surface.

Follow the care instructions and look after your furniture, in return, your furniture will look after you.

We hope to see you soon!

Frequently Asked Questions

1. What should I do if my product received is incomplete?

Mopio products are flat packed and come in separate boxes. Once your order has dispatched and been sent with Fedex, you will receive an email with tracking information. Please note that Fedex may deliver your boxes in separate deliveries. Kindly follow the tracking information, allowing all boxes to be received before starting assembly. If you need further assistance on deliveries tracking, feel free to reach out to us at www.mopio.com#chat or help@mopio.com.

2. What should I do if my shipment is damaged or products received are defective?

We're sorry to hear that! Please email us at help@mopio.com or chat with us at www.mopio.com#chat and provide a detailed description of the damage, as well as photos (or videos, where appropriate) showing the damage. We will do our best to resolve the issue as soon as possible.

3. Can replacement parts be ordered?

Yes. Simply write to our customer service team at help@mopio.com or chat with us at www.mopio.com#chat, let us know your order ID and we will be happy to assist further.

4. Who do I contact for repair queries?

You may write to us at help@mopio.com specifying your queries and we will be able to assist you further.

5. What warranty do you offer for your products?

You'll just need to submit your warranty registration upon receiving product at www.mopio.com/warranty/register. You may provide your order ID or upload your order confirmation page as your proof of purchase. More details can be found in **Warranty section**.

6. How do I claim my warranty?

Easy! Just email us at help@mopio.com and provide a detailed description of the fault as well as photos.

7. What should I do if I want to return the product?

We offer a 30-day return policy upon product received. To initiate a return request, please contact our customer service team at help@mopio.com or www.mopio.com#chat with your reason of returning so we can facilitate the request and assist you further. For more details on the return policy, please refer to **Return section**.

Warranty & Return

1 YEAR LIMITED WARRANTY STATEMENT FOR MANUFACTURING DEFECTS

Please read this limited warranty carefully. To maintain your warranty, you will need to comply with the conditions stated here. This warranty is for manufacturing defects only and does not cover damages as a result of misuse.

1. Please be sure to register your product at www.mopio.com/warranty/register to activate your warranty. We recommend you doing so within 30 days upon receiving.
2. Your new product comes with 1-year warranty against manufacturing defects, upon activation. The warranty starts on the date of receipt. No warranty will be honored without a proof of purchase. The warranty and financial responsibility of the manufacturer only applies to the products itself.
3. Manufacturing defects include circumstances where the product has broken under normal use and no longer provides proper support. In the event you encounter a manufacturing defect, please stop using this product immediately and contact customer service.
4. This warranty applies only when the product has been properly used by consumers who purchased the product from authorized channels as a new product. Proper use means using the product on a level surface where all legs touch the floor with an equal distribution of weight. Proper use also means that the product was not abused by the consumer, as defined by the manufacturer. This warranty does not constitute agreement to replace other parts.
5. If the product fails due to manufacturing defects, the manufacturer will repair or replace at its discretion and reserves the right to substitute comparable materials or models and does not guarantee that the replacement part will match existing pieces.
6. In the event the product needs to be inspected by the manufacturer to determine a warranty claim, the transportation cost or removal cost is borne by the consumer.

MOPIO'S 30-DAY RETURN POLICY

We believe you will be thrilled with your purchase from Mopio. That's because we go out of our way to ensure that products are designed and built to be just what you need. We understand, however, that sometimes a product may not be what you expected it to be. In that event, we invite you to review the following terms related to returning a product.

The Return

Returns are to be made within 30 days of the date you received the product. To initiate return request, please message us or contact our customer service team at help@mopio.com or www.mopio.com#chat with your reason of returning so we can facilitate the request and issue return authorization to you. Please note the policy is subject to the conditions below:

1. Only undamaged items in original packaging will be accepted under the Returns Policy. Any items that are not returned to us in the original packaging and/or in original condition will incur an additional handling fee (deducted from your refund). It is your responsibility to package the item sufficiently to avoid damage in transit back to us. We encourage customers to photograph the items scheduled for return and the condition of the packaging before handing over to the delivery company.
2. We will not refund a product that you have bought and received where, in our reasonable opinion, the product has: become of unacceptable quality due to fair wear and tear; misuse; using it in an abnormal way; or failure to take reasonable care.
3. We will not be able to offer standard return policy after 30-day timeframe has passed. However, our customer service team is always an email away if you require further assistance with your Mopio products.

The Refund

We will assist you to complete the return process. We will perform standard inspection upon your return is received and will send you a message to acknowledge the return if item is presenting in original condition with original packaging.

You will be refunded the full amount less return shipping cost. Please note that while shipping charges on original deliveries are subsidized, on returns the full shipping amount paid by Mopio to the delivery partner will be deducted from your refund. **All refunds will take 2 business days to process upon return acknowledgement from us, however actual fund reversal date will depend on your card company's own processing schedule.**

Kindly note, in the event of returning a defective or damaged item, **we will however absorb the shipping charges and ensure your return/exchange experience is hassle free.**

The Exchange

We put quality as one of our top priorities – we work with experienced manufacturers and have every piece of Mopio product going through strict quality control process. We want to make sure your Mopio product reaches you safe and sound, however we are happy to do an exchange in case you receive a defective or damaged product due to any unforeseen hiccups throughout the journey. Please message us or email us at help@mopio.com with proof of defect or damage, our customer service will evaluate the exchange request, and assist you throughout the process accordingly.