

LAUREN ARCHED CABINET

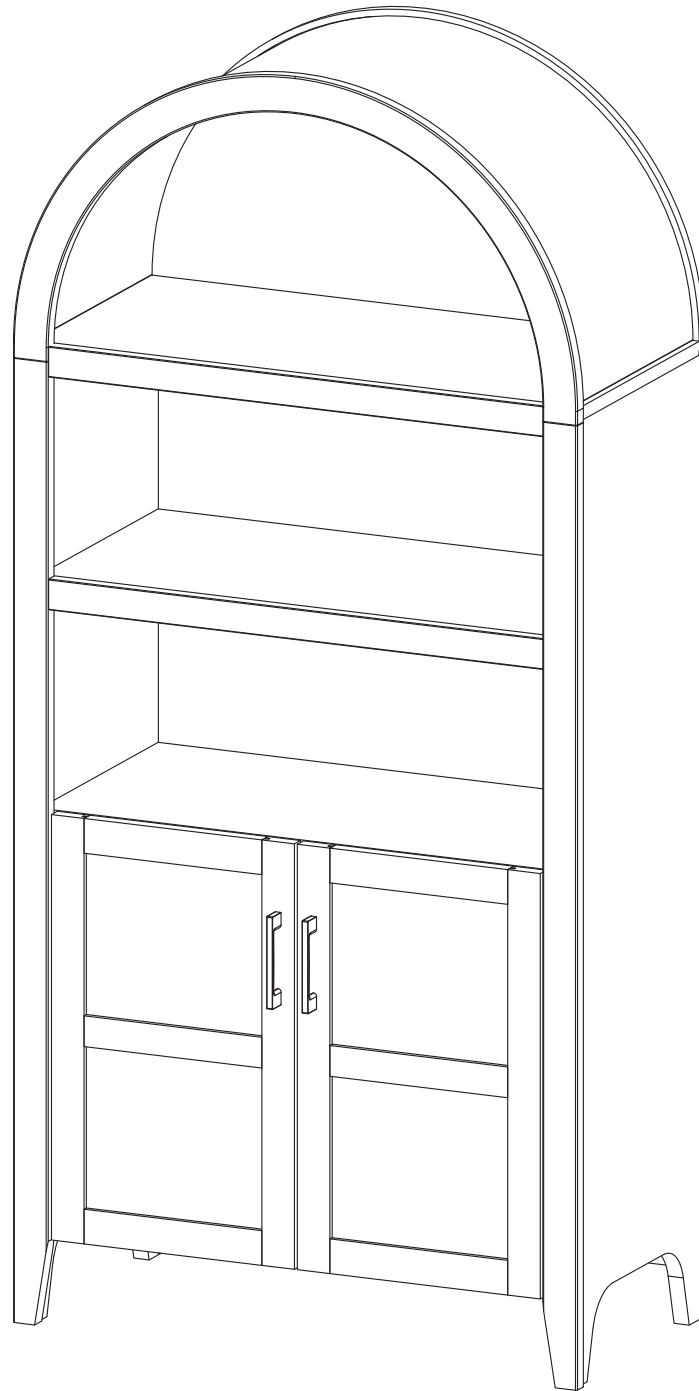

ASSEMBLY INSTRUCTIONS

mopio[®]

Join Mopio Club and enjoy your 1-Year Warranty

We've got more for you. Be part of **Mopio Club** and enjoy:

- Privileged Customer Care
- 10% Off Your Next Purchase (no min spend)
- 1-Year Free Warranty
- Early Access To Upcoming Launches

Scan the QR code or go to the link to find out more:
www.mopio.com/club



Chat With Us!

For any enquiries or issues regarding your purchase, chat with us at www.mopio.com/chat.

Or connect with us through other channels:

✉ help@mopio.com

📘 @mopioinc

🌐 www.mopio.com

Before you start...

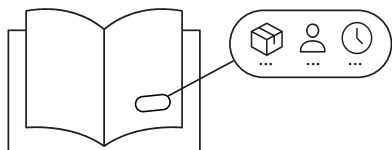

Ensure you have received all cartons and familiarize yourself with the workload. Make sure there are enough helping hands to assist you, and that you have allocated the time required to assemble your new product.

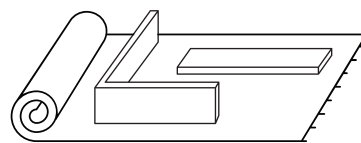

Make sure you have cleared enough space in your home for the assembly. We recommend protecting your floor with a mat or cardboard to avoid scratches during the assembly process.

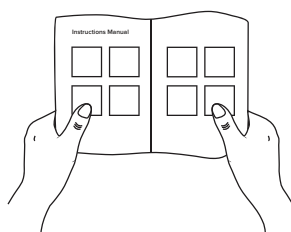

Read instructions carefully and check no parts are missing.

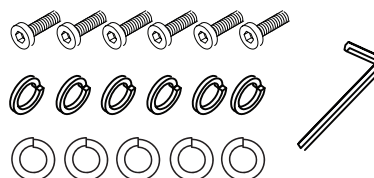

Lay out all hardware on a soft surface so you can easily identify them.

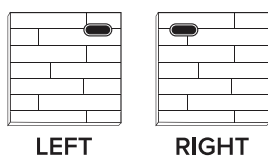

Carefully identify all components in order to differentiate which pieces are left and right.

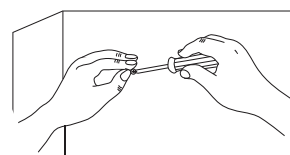

Install your new product carefully following the instructions. Don't skip ahead!

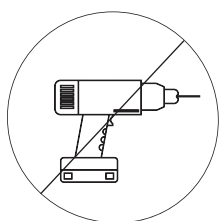

DO NOT over tighten screws or use a drill. It will damage the product.



If you need further assistance with assembling your Mopio product, please chat with us at www.mopio.com#chat.

Parts

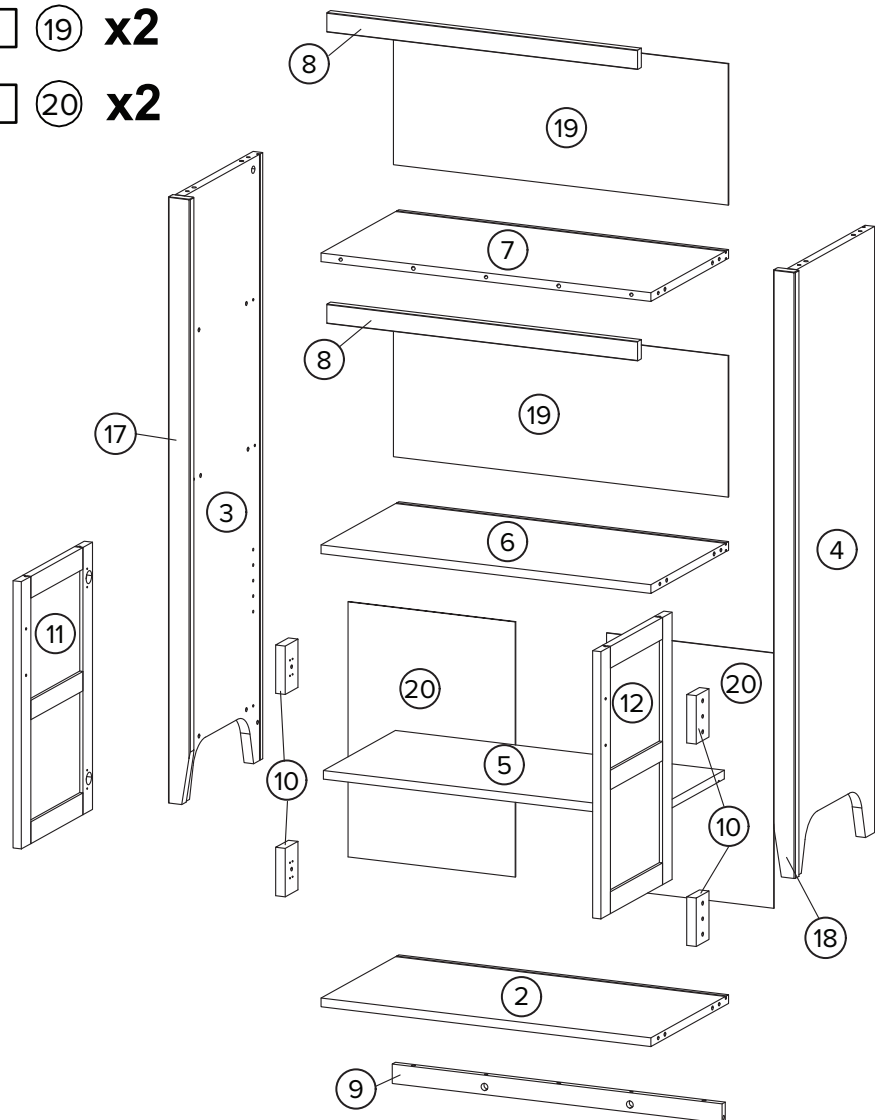
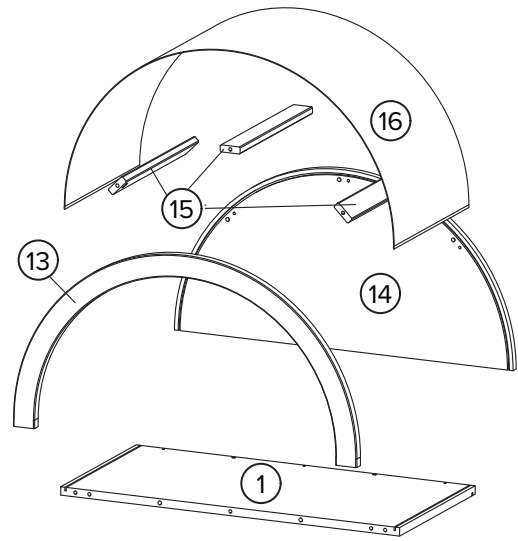

Watch installation demo video at:
<https://bitly.ws/36LbT>

- | | |
|--------------------------------------|--------------------------------------|
| <input type="checkbox"/> ① x1 | <input type="checkbox"/> ⑪ x1 |
| <input type="checkbox"/> ② x1 | <input type="checkbox"/> ⑫ x1 |
| <input type="checkbox"/> ③ x1 | <input type="checkbox"/> ⑬ x1 |
| <input type="checkbox"/> ④ x1 | <input type="checkbox"/> ⑭ x1 |
| <input type="checkbox"/> ⑤ x1 | <input type="checkbox"/> ⑮ x3 |
| <input type="checkbox"/> ⑥ x1 | <input type="checkbox"/> ⑯ x1 |
| <input type="checkbox"/> ⑦ x1 | <input type="checkbox"/> ⑰ x1 |
| <input type="checkbox"/> ⑧ x2 | <input type="checkbox"/> ⑱ x2 |
| <input type="checkbox"/> ⑨ x1 | <input type="checkbox"/> ⑲ x2 |
| <input type="checkbox"/> ⑩ x4 | <input type="checkbox"/> ⑳ x2 |



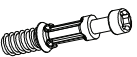

Hardware

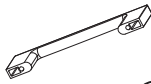

Watch installation demo video at:
<https://bitly.ws/36LbT>

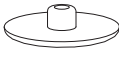
 Cambolt
 Ø 6 x 35 mm
(A) x40

 Handle
(H) x2

 Screw Cap
 Ø 15 mm
(O) x3

 Camlock
 Ø 15 mm
(B) x40

 Screw
 M 4.5 x 12.5mm
(I) x24

 Screw Cap
 Ø 15 mm
(P) x12

 Dowel
 Ø 8 x 30 mm
(C) x46

 Wedge
(J) x20

 Buffer
(Q) x2

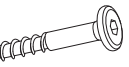
 Screw
 M 6.4 x 35 mm
(D) x4

 Screw
 M 6.4 x 35 mm
(K) x20

 Hinge
(R) x4

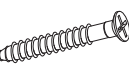
 Dowel
 M 8 x 39 mm
(E) x3

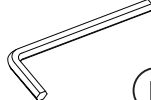
 Allen Key
(L) x2

 Rubber
(S) x1
 Hardware is not included in Natural Oak.
 Hardware is only applicable if you purchased Black Oak.

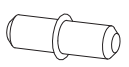
 Shelf Pin
(F) x4

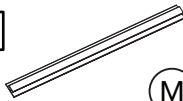
 List Joint
(M) x1

 Screw
 M 4 x 25 mm
(G) x4

 Floor Protector
(N) x4



 This product will require 2hrs for assembly. We hope that you will enjoy the assembly process and hang in there!

 There are inner box(es) that include components required to complete this assembly.

 Please do not completely tighten all the hardware, until each assembly step is complete.

 Before discarding the packaging, please use the checklist to ensure that you have all the parts required to assemble your product. Please kindly note you will need the original package if you want to return the product later.

 If parts are missing or damaged, we will gladly ship your replacements parts free of charge. Please contact us at help@mopio.com or chat with us at www.mopio.com#chat.

 **x1**
 **x2**
 **120 mins**

Step 1

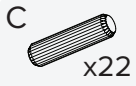
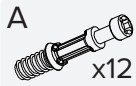
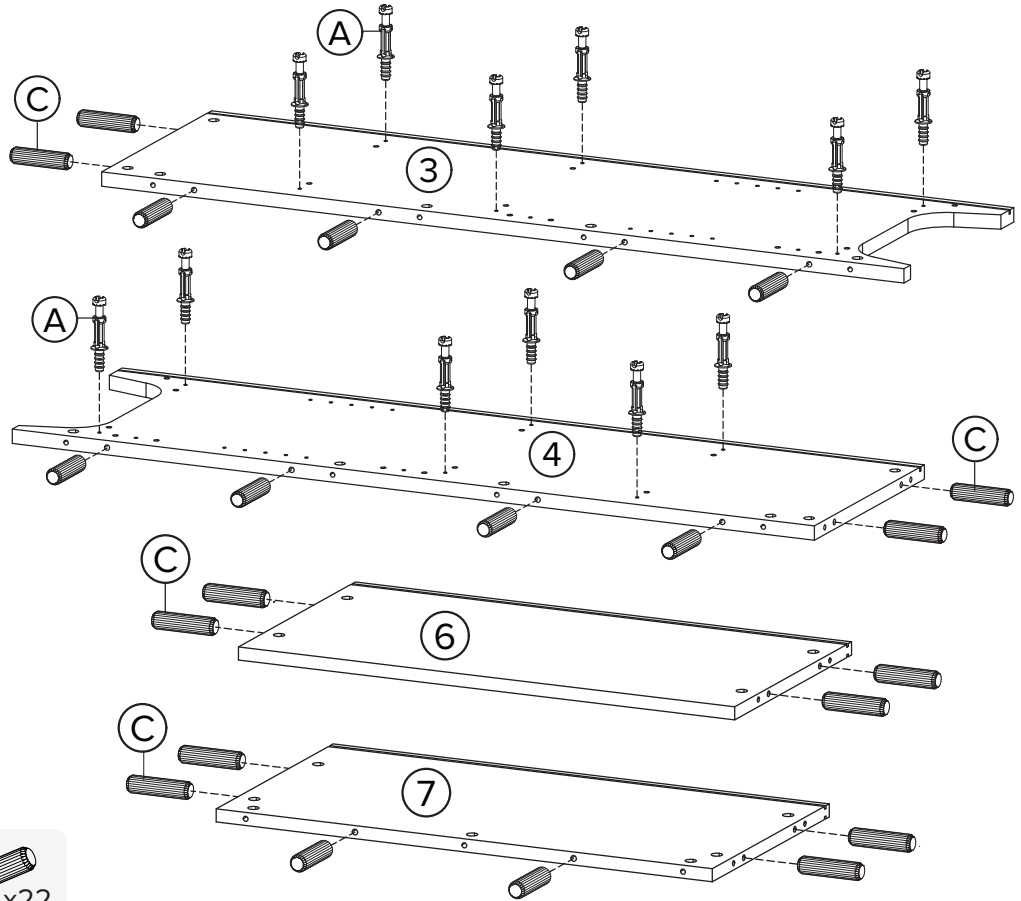
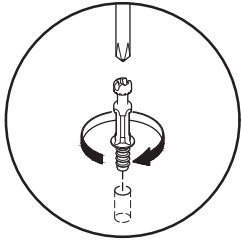

Step 2

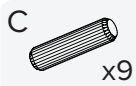
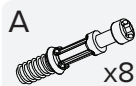
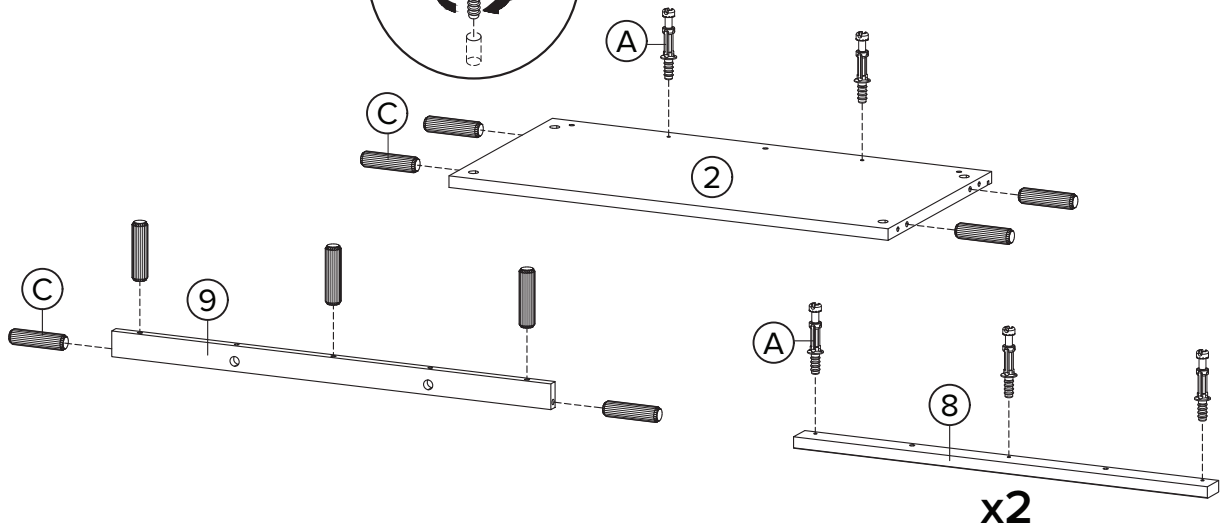
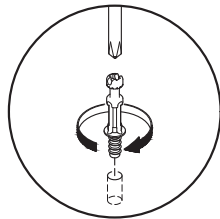

 **Missing parts? Or feeling stuck?**
Chat with us at www.mopio.com/#chat

 **Watch demo video at:**
<https://bitly.ws/36LbT>

Step 3

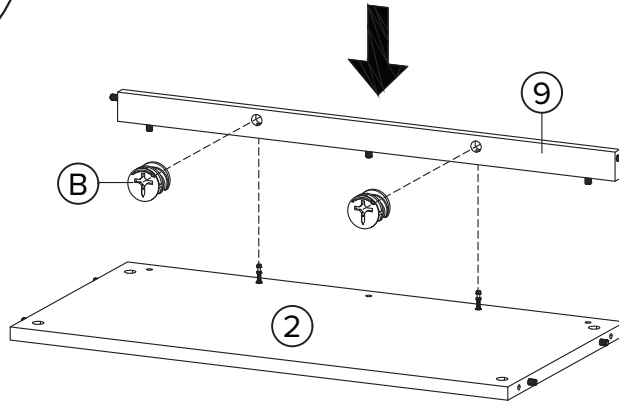
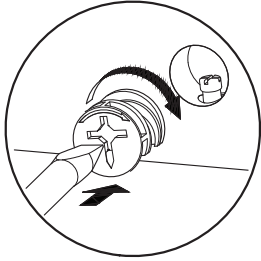

Step 4

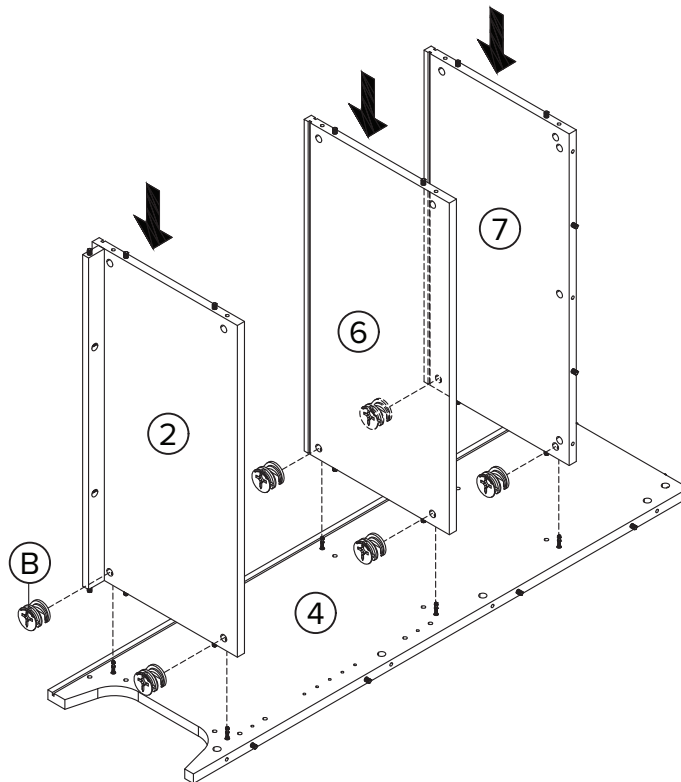
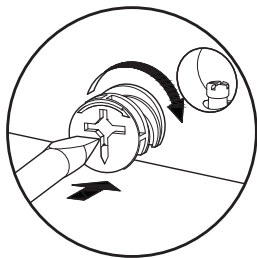

 **Missing parts? Or feeling stuck?**
Chat with us at www.mopio.com/#chat

 **Watch demo video at:**
<https://bitly.ws/36LbT>

Step 5

Illustration 1

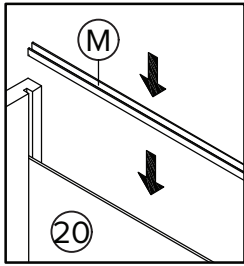
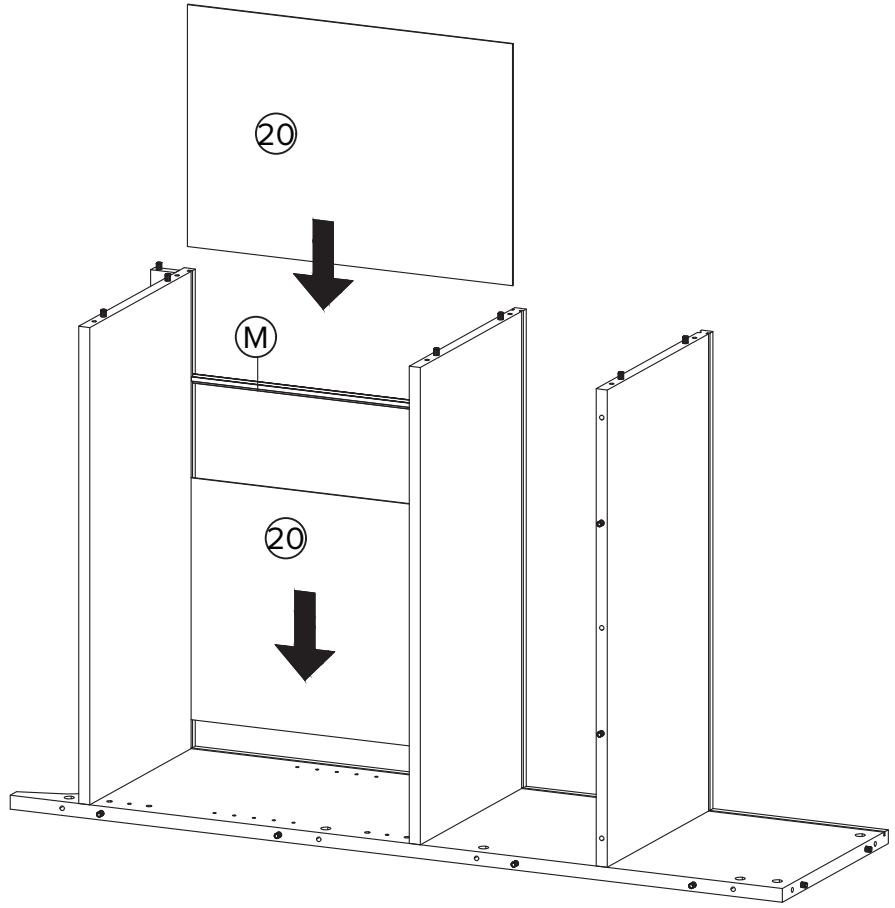
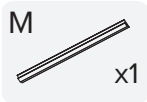
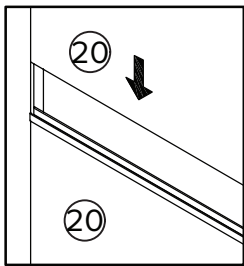
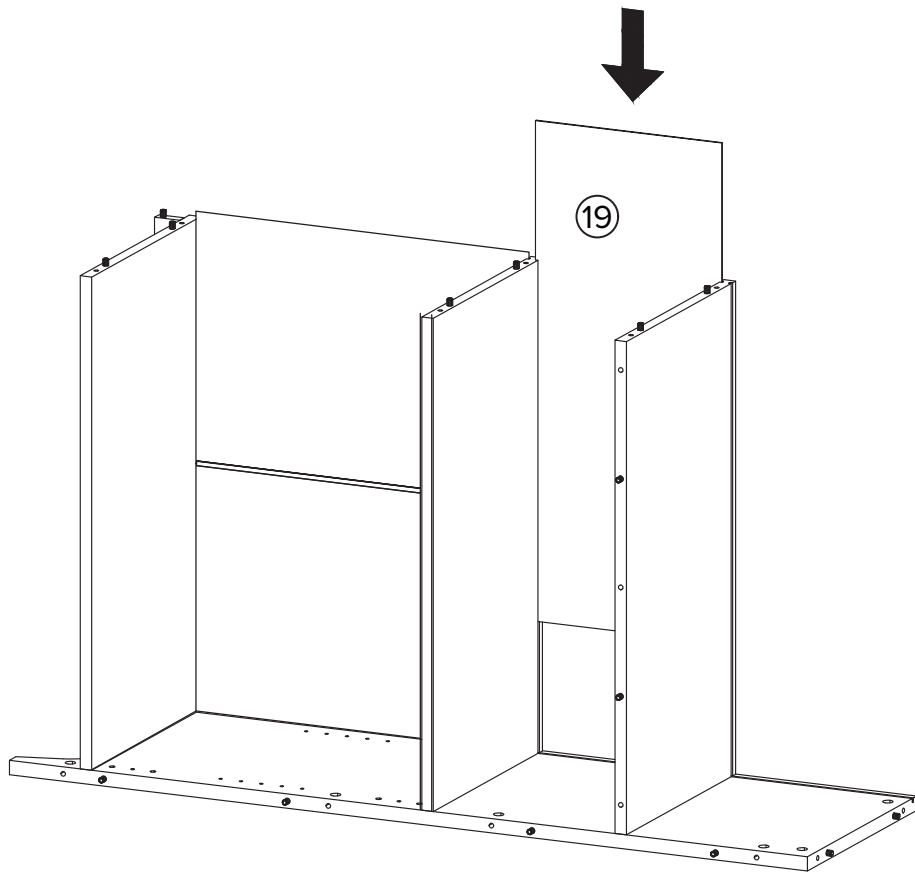

Illustration 2



Step 6



Missing parts? Or feeling stuck?
Chat with us at www.mopio.com/#chat



Watch demo video at:
<https://bitly.ws/36LbT>

Step 7

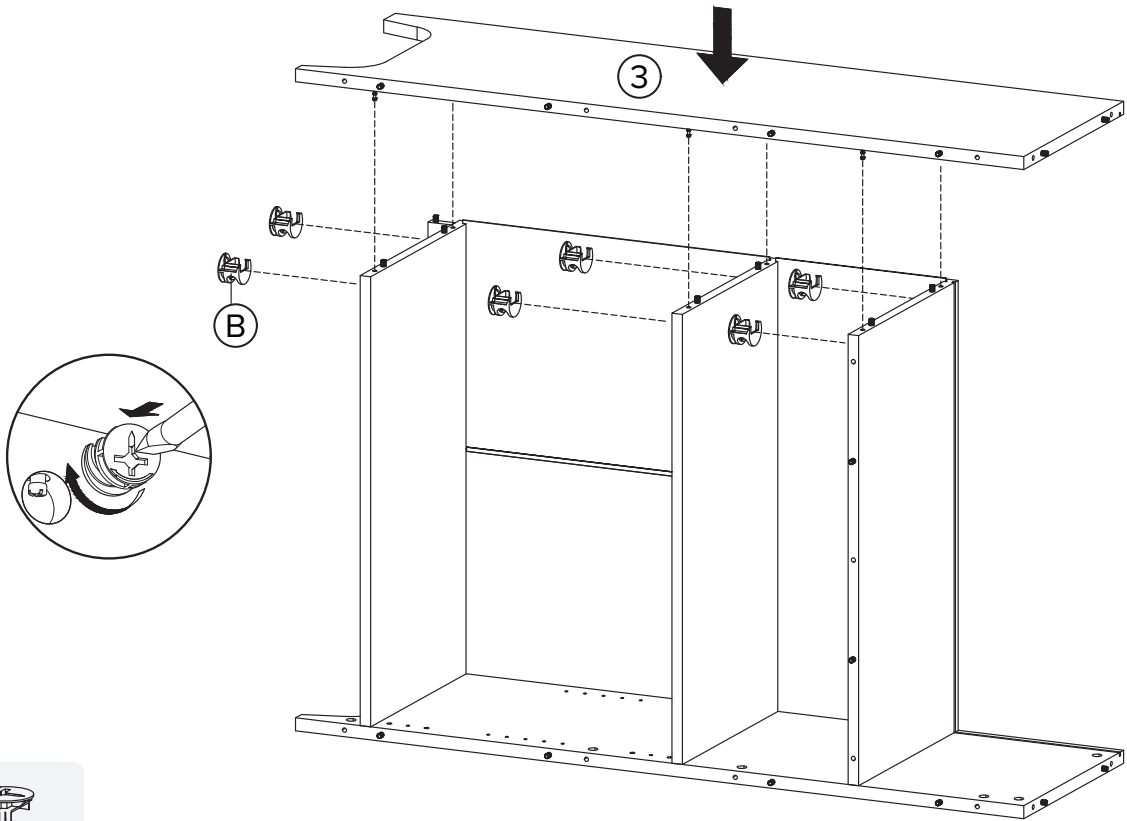

Step 8

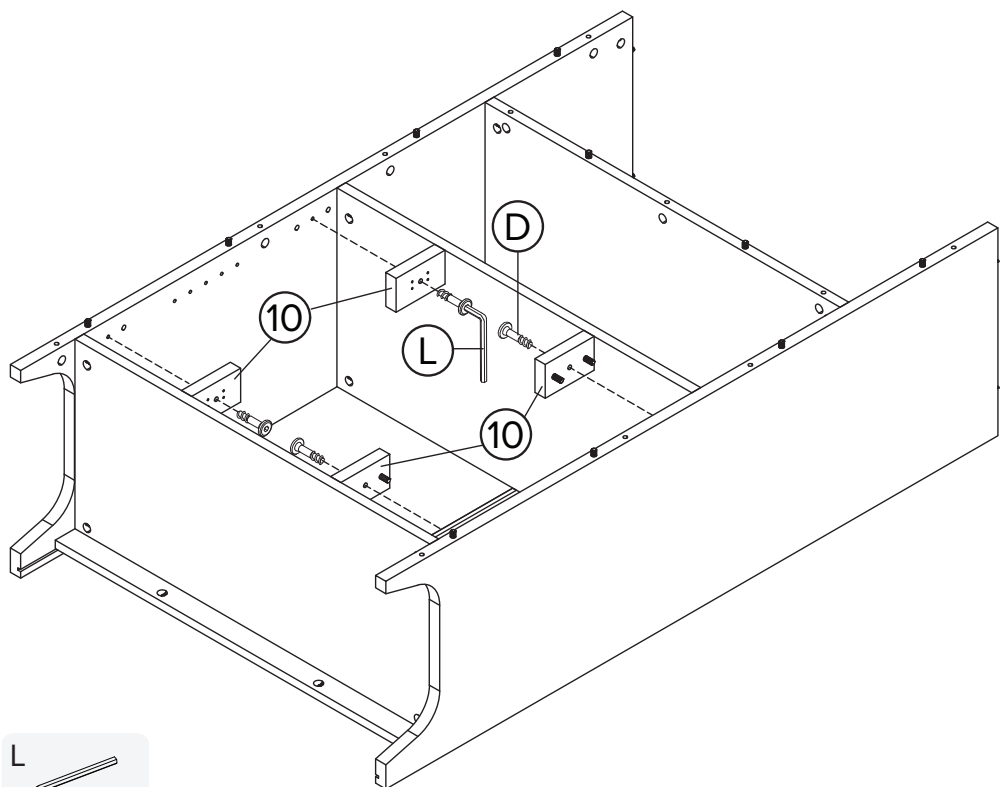
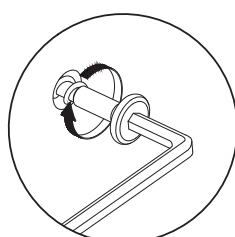
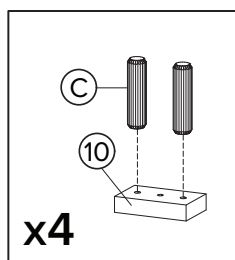

Missing parts? Or feeling stuck?
Chat with us at www.mopio.com/#chat

Watch demo video at:
<https://bitly.ws/36LbT>

Step 9

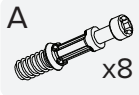
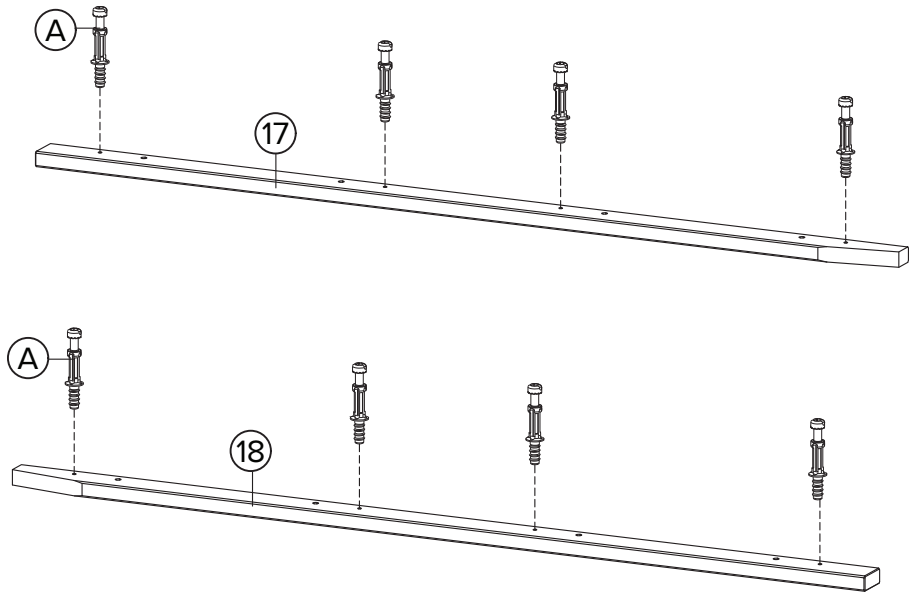
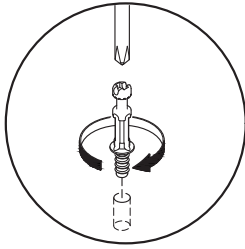

Step 10

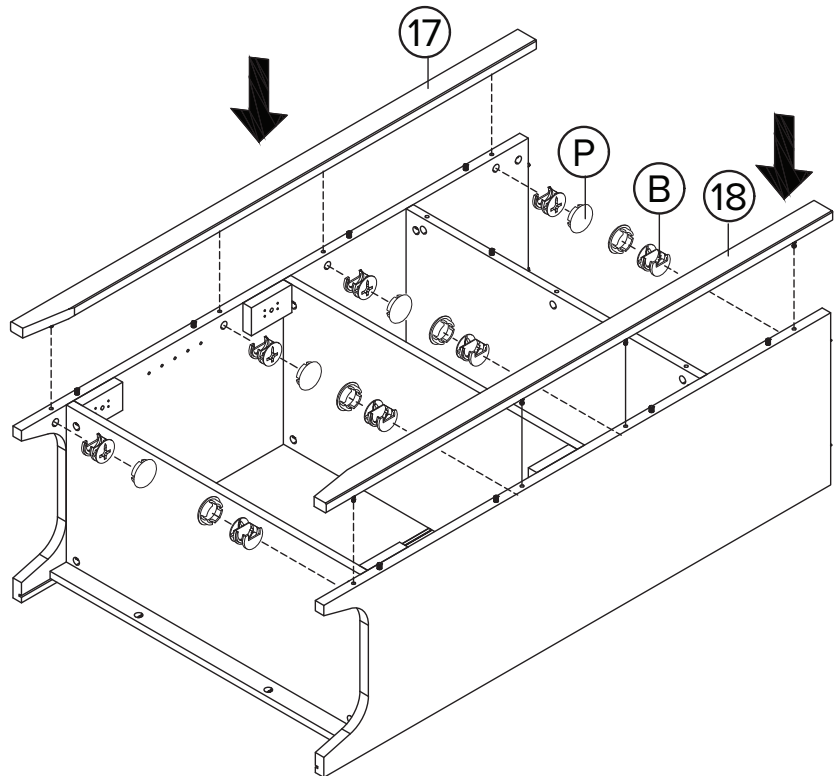
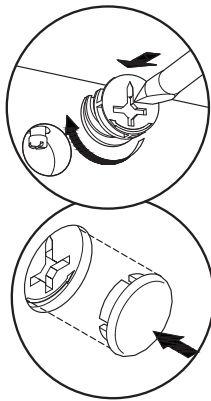

Missing parts? Or feeling stuck?
Chat with us at www.mopio.com/#chat



Watch demo video at:
<https://bitly.ws/36LbT>

Step 11

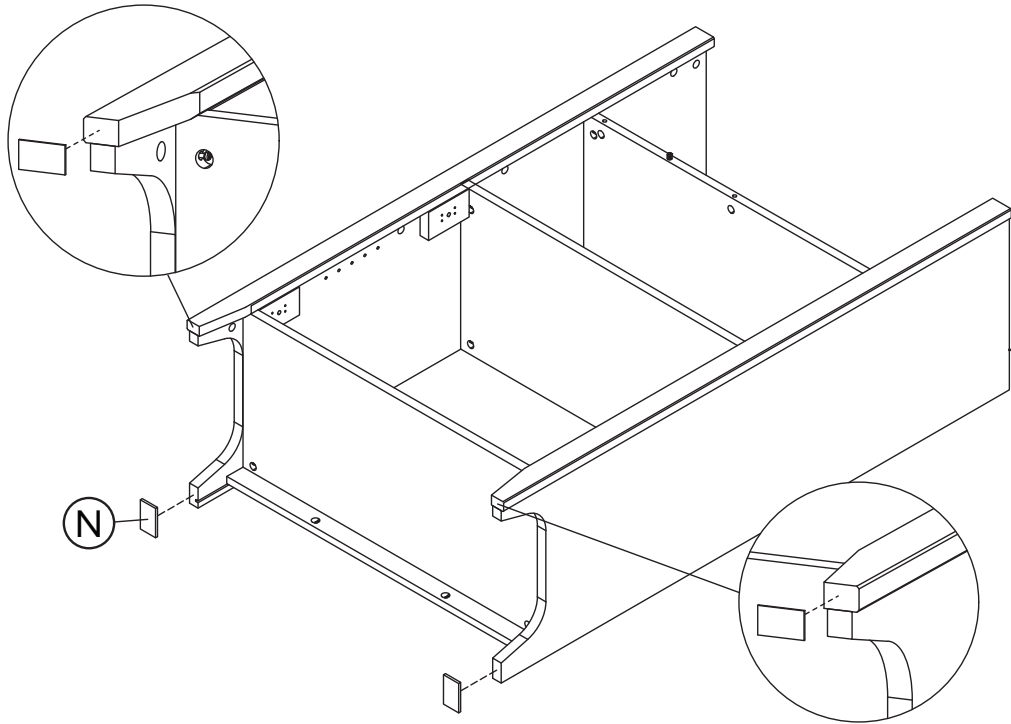

Step 12

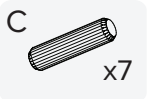
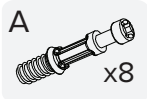
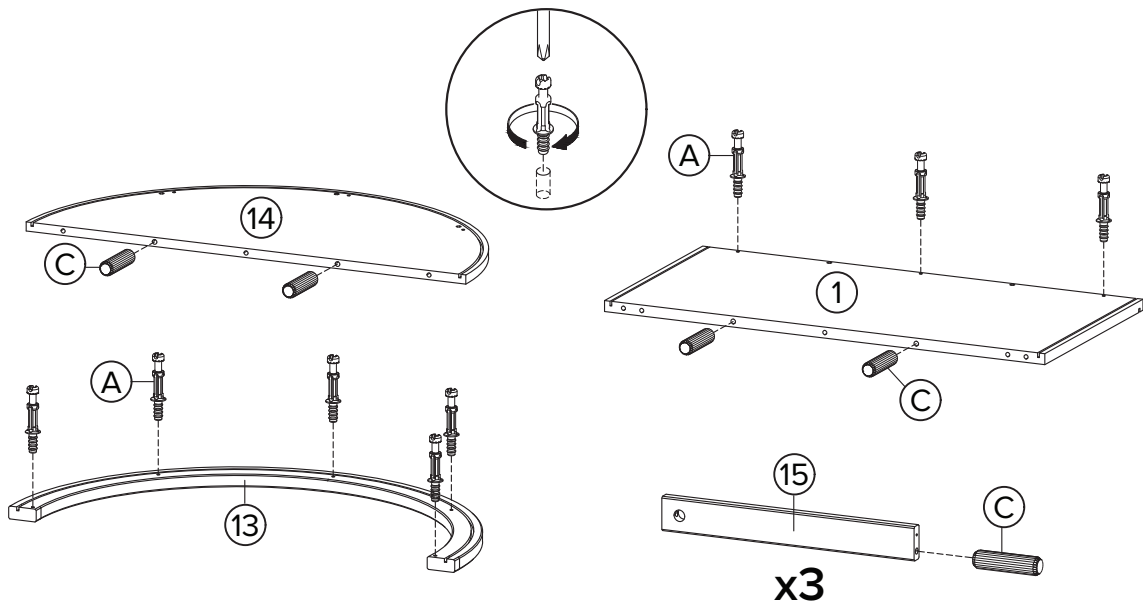

Missing parts? Or feeling stuck?
Chat with us at www.mopio.com/#chat

Watch demo video at:
<https://bitly.ws/36LbT>

Step 13

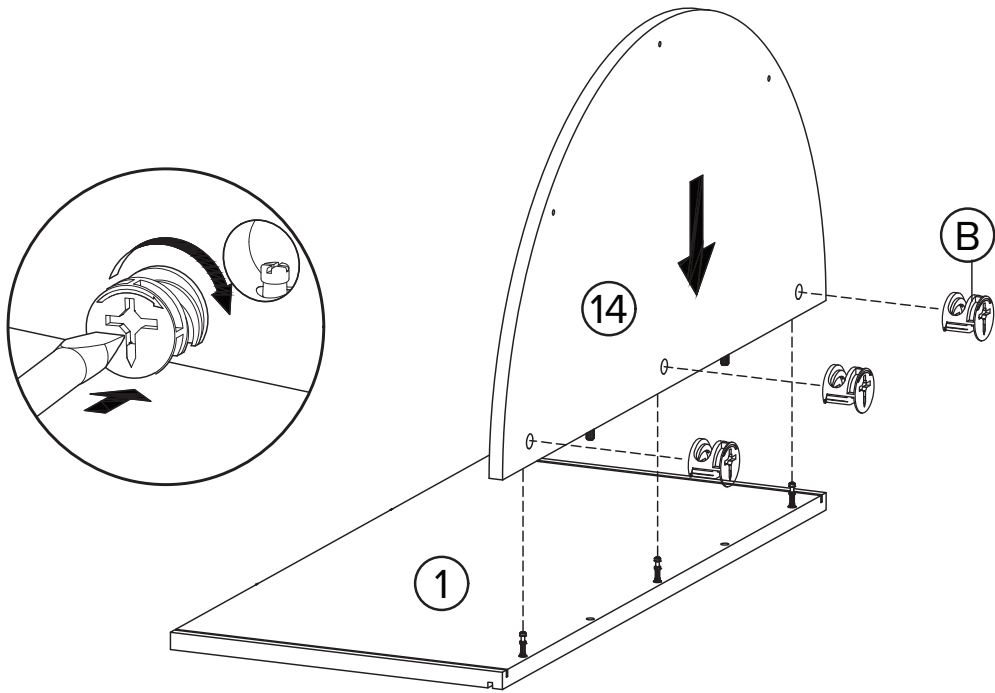

Step 14

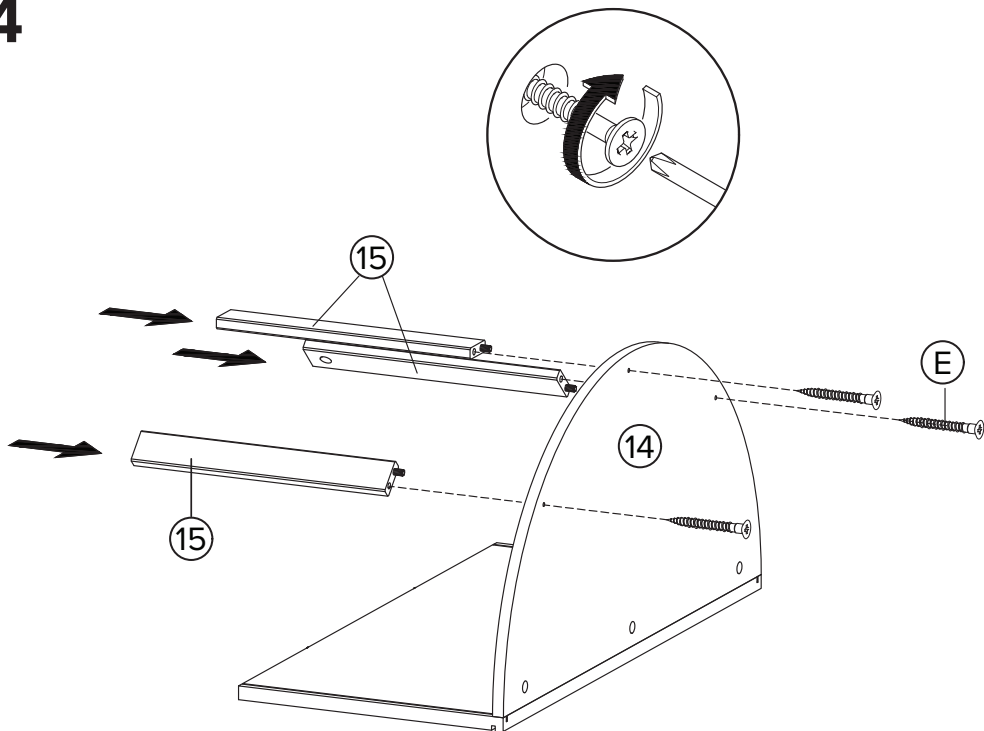

? Missing parts? Or feeling stuck?
Chat with us at www.mopio.com/#chat

▶ Watch demo video at:
<https://bitly.ws/36LbT>

Step 15

Gently bend Panel 16 according to the shape required and slot into the groove.

Avoid applying excessive force.

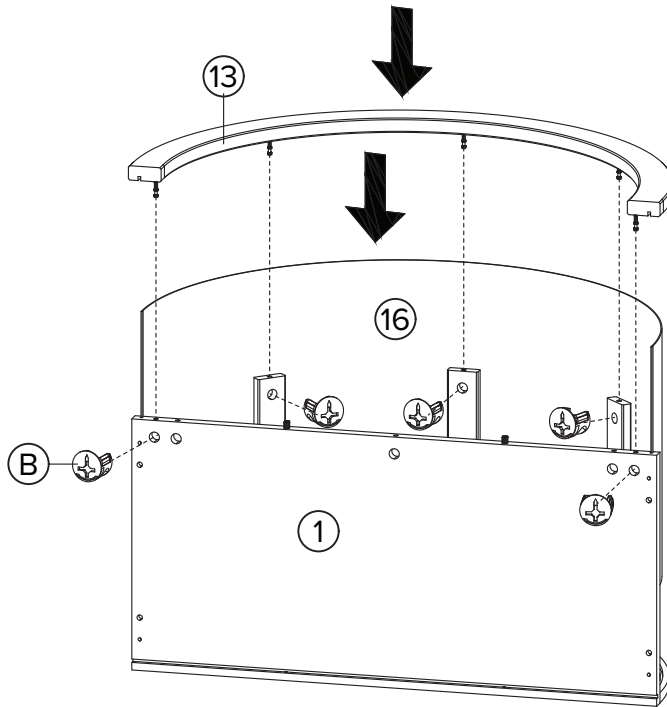
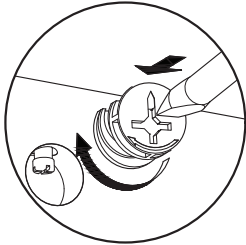

Step 16

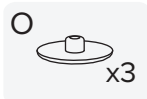
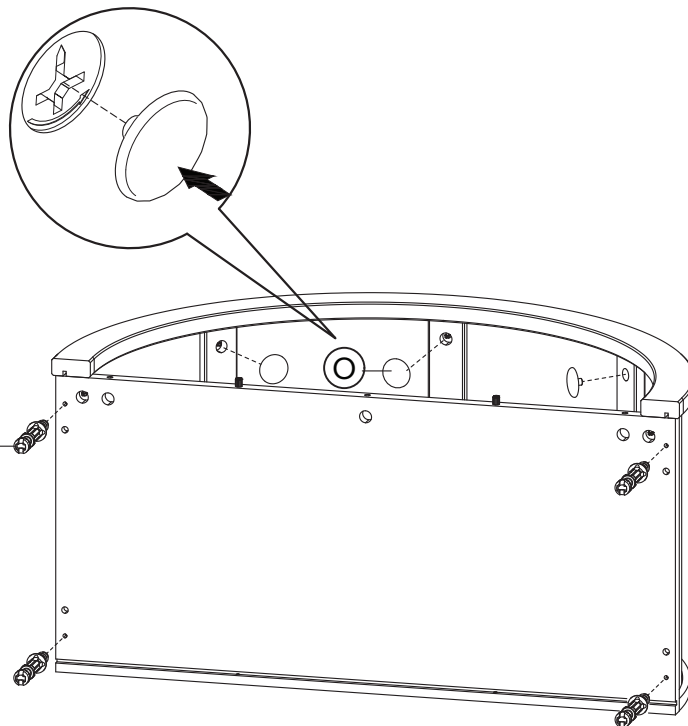

Missing parts? Or feeling stuck?
Chat with us at www.mopio.com/#chat



Watch demo video at:
<https://bitly.ws/36LbT>

Step 17

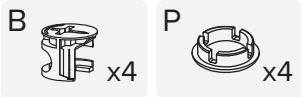
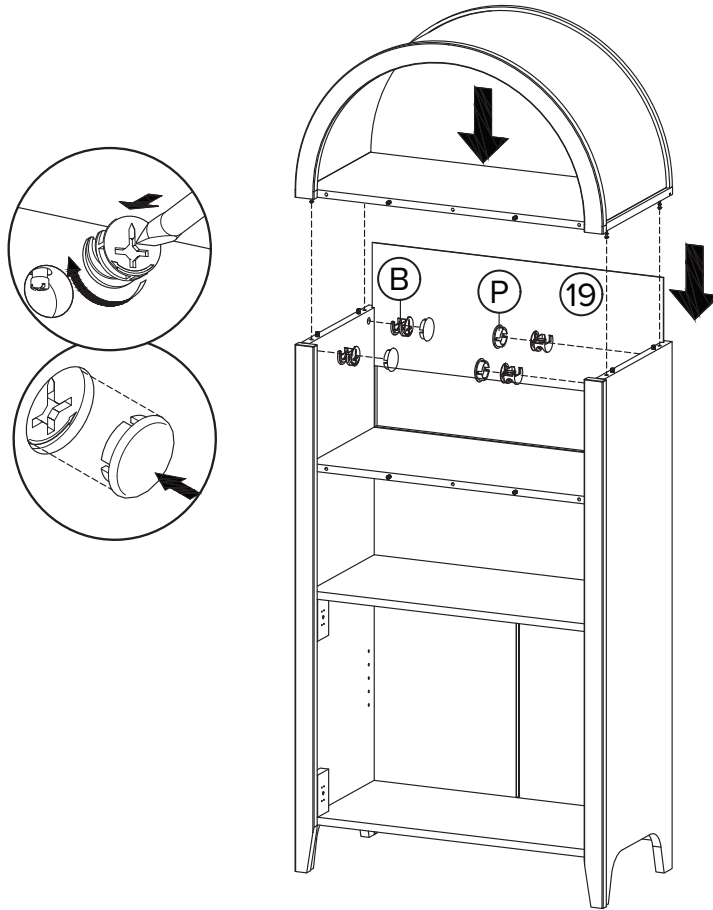

Step 18

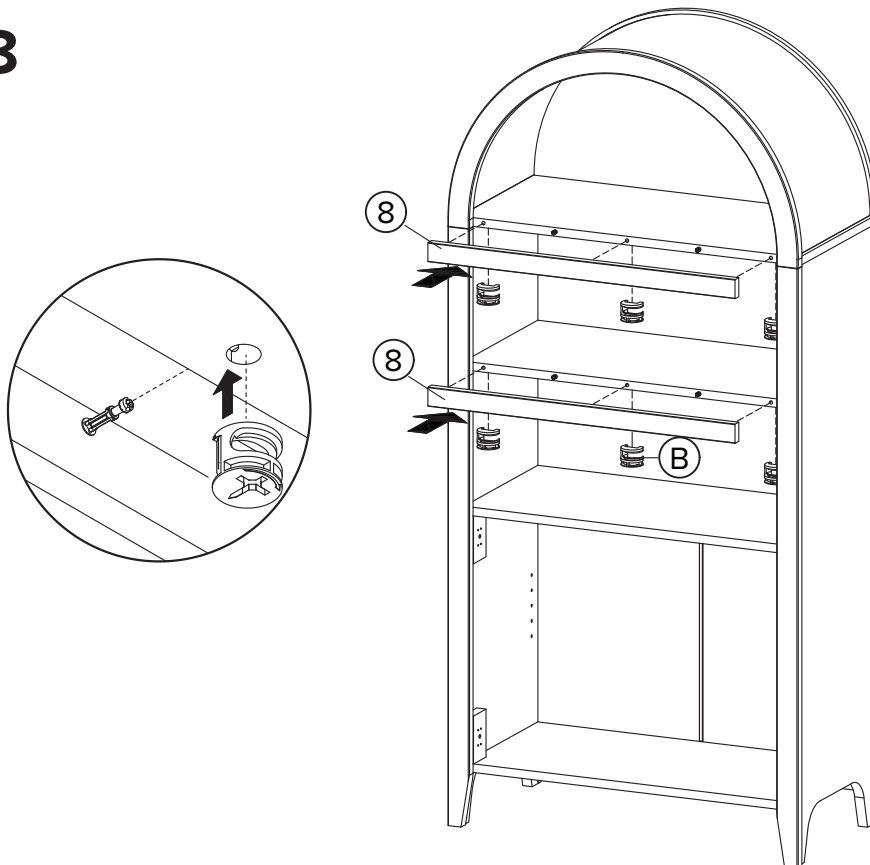

? Missing parts? Or feeling stuck?
Chat with us at www.mopio.com/#chat

▶ Watch demo video at:
<https://bitly.ws/36LbT>

Step 19

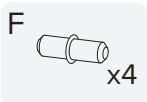
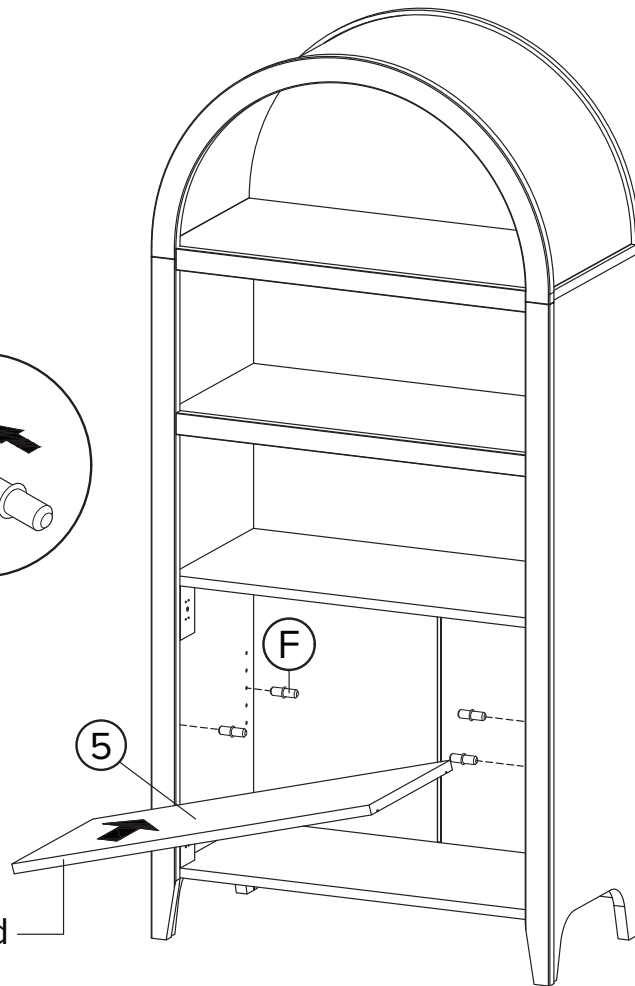
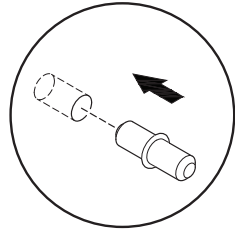

Laminated

Step 20

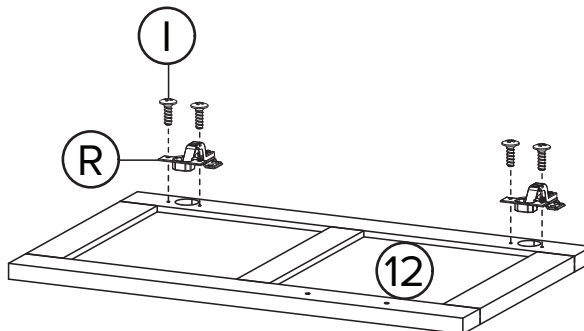
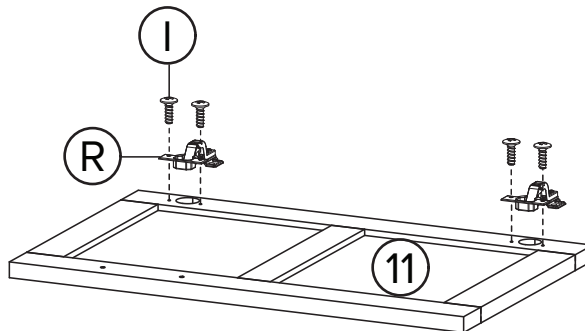
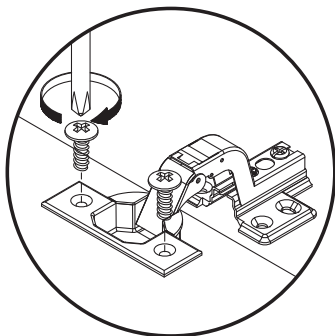

Missing parts? Or feeling stuck?
Chat with us at www.mopio.com/#chat



Watch demo video at:
<https://bitly.ws/36LbT>

Step 21

To Install

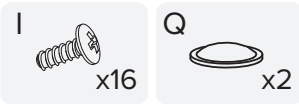
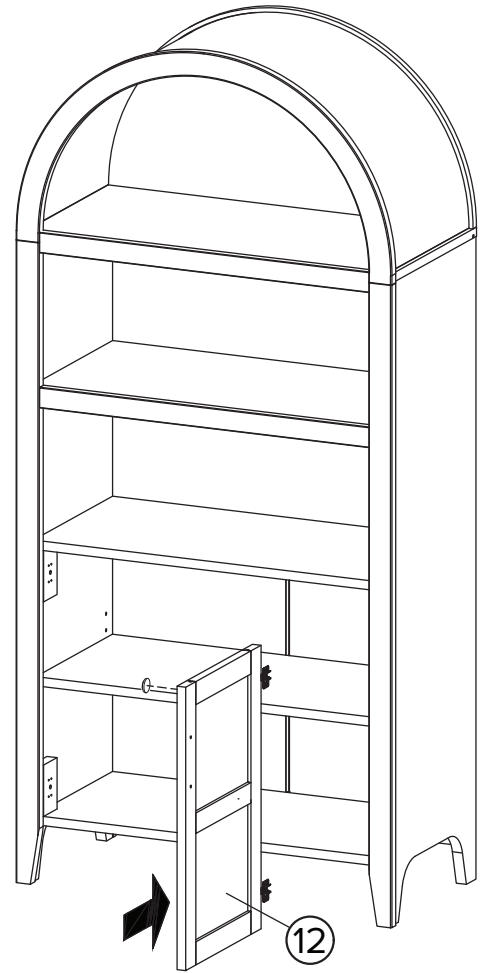
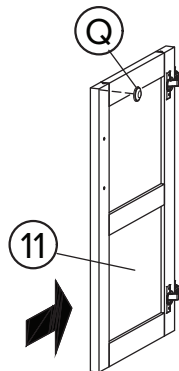
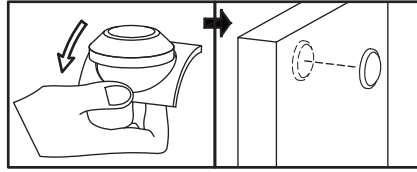
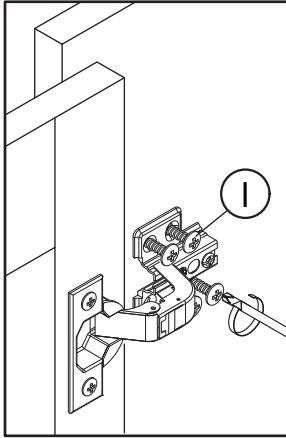

Step 22

To adjust the door in a front and back direction, loosen front screw a little and back screw completely. Push the door and re-tighten the back screw.

To adjust the door in a left right direction, adjust the front screw.

To adjust the door in an up down direction, loosen the screw on the mounting plate as shown. You may need to loosen 2 hinges in order to perform this adjustment. Push the door up or down to preferred position before retightening it

To Adjust

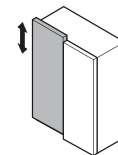
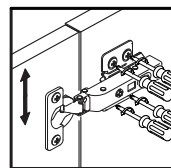
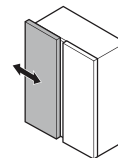
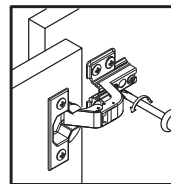
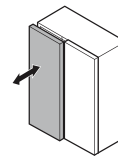
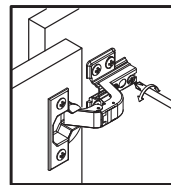

Missing parts? Or feeling stuck?
Chat with us at www.mopio.com/#chat



Watch demo video at:
<https://bitly.ws/36LbT>

Step 23

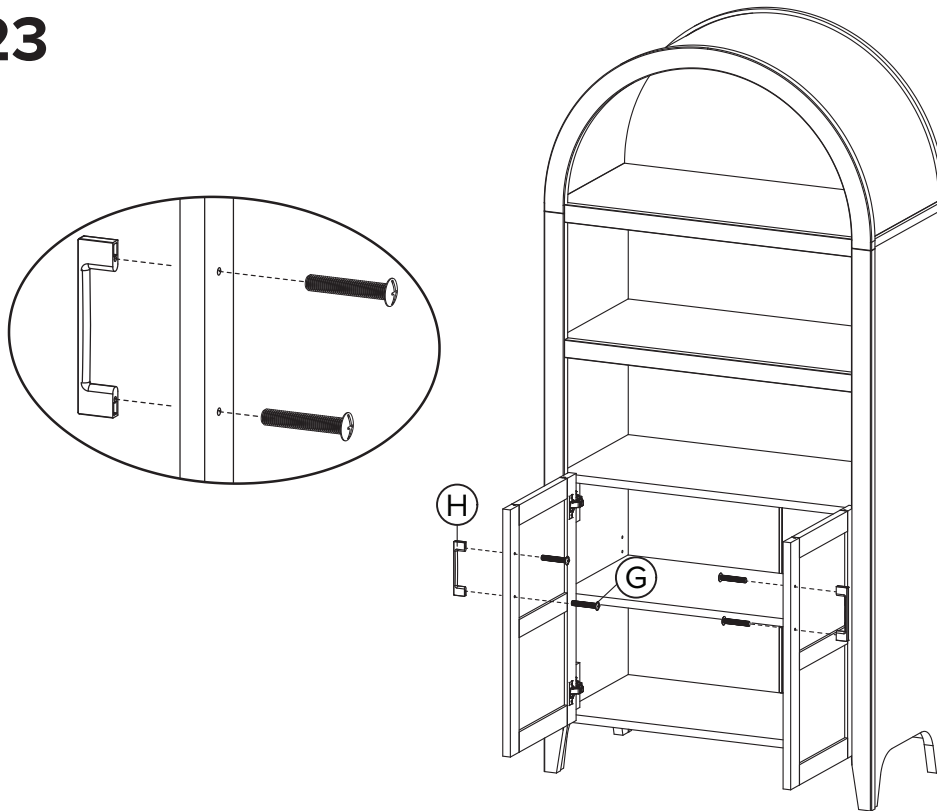

Step 24

To ensure the stability of product, ensure that all wedges have been properly installed according to the illustration.

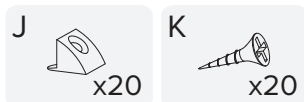
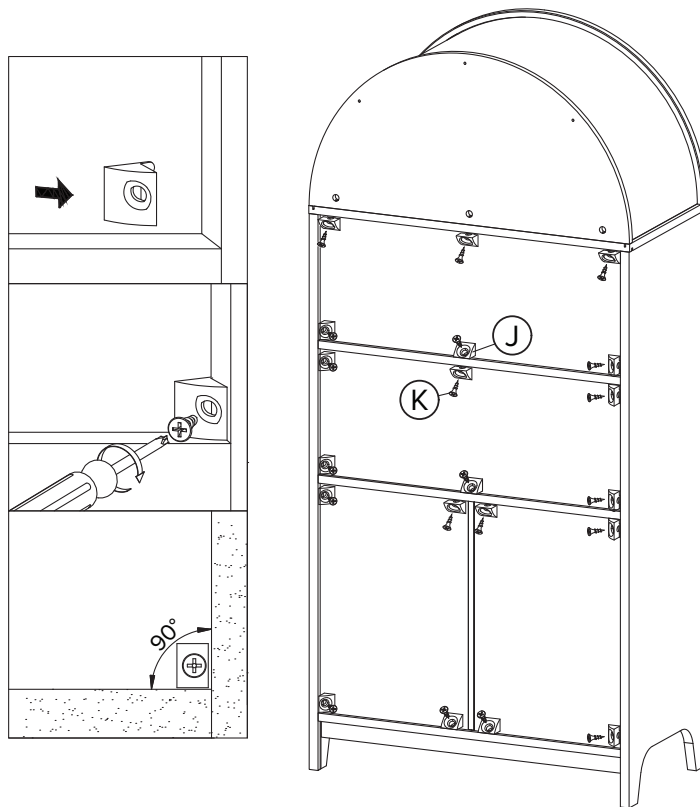

Missing parts? Or feeling stuck?
Chat with us at www.mopio.com/#chat



Watch demo video at:
<https://bitly.ws/36LbT>

Step 23

This step is applicable for Black Oak version only.

This step is not applicable for Natural Oak.
We do not provide hardware "S" for Natural Oak version.

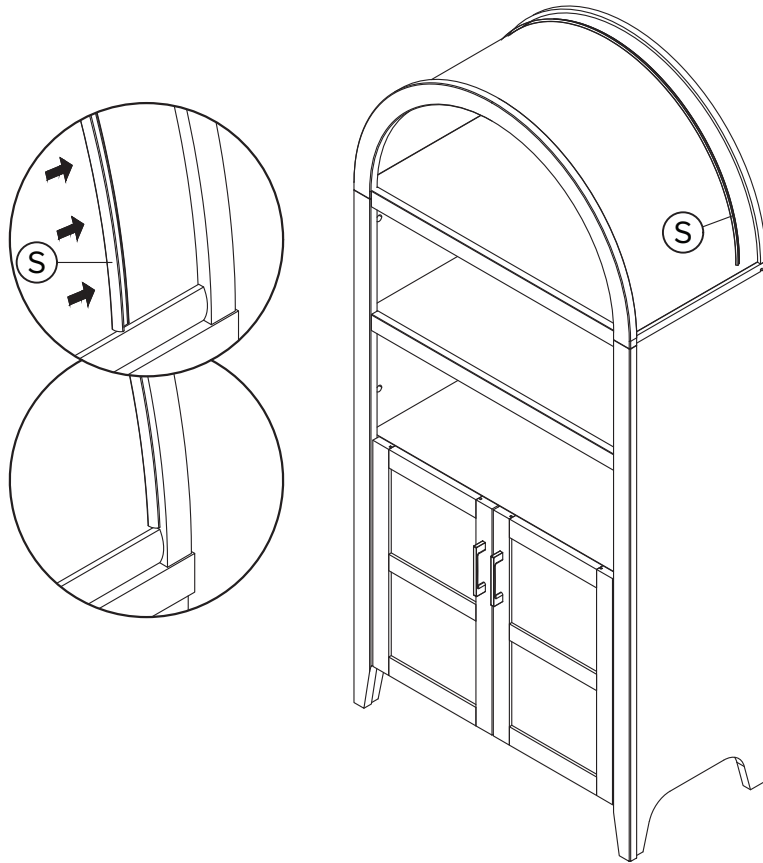

Finished!

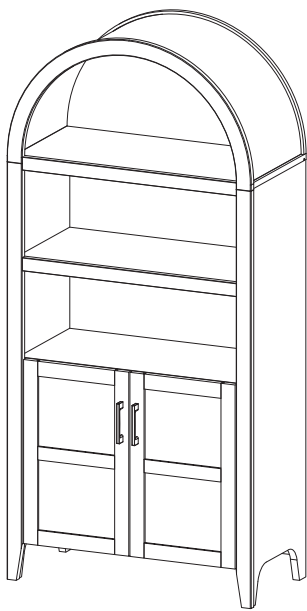

Congratulations, you have made it through the assembly process! We're almost there!☆

Please perform following checks to ensure assembly is properly done.

- If the door's gap is misaligned, please refer to Step 22.
- Ensure wall anti-tipping is installed, please refer to the page on Tipping Restraints Kit Installation Guide.

Move your Mopio product carefully, with 2 people lifting it to the preferred location. Clean the product with a dry cloth. You are all set!

Enjoy your fresh and updated living space thanks to the addition of your new Mopio product!



Missing parts? Or feeling stuck?
Chat with us at www.mopio.com/chat



Watch demo video at:
<https://bitly.ws/36LbT>

Tipping Restraints Kit Installation Guide

Anti-tip Kit

To prevent injury or property damage from the unexpected tipping of furniture, we highly recommend installing the anti-tip kit included in this product.

Periodically check the screws. In case of loosening, change the screw position.

With extra help, move the product into position. Please do not drag the product across your floor.

Reposition product and fix using hardware recommended.

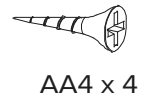
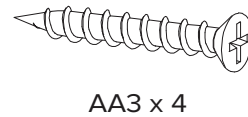
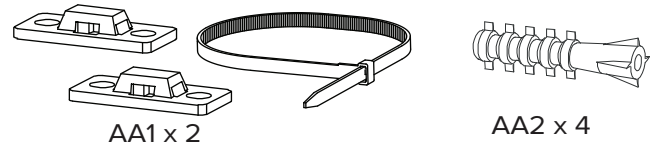

1. Attach bracket (AA1) securely to the back top of the furniture using screw (AA4) provided.

Allow 8 - 10 cm from each side.

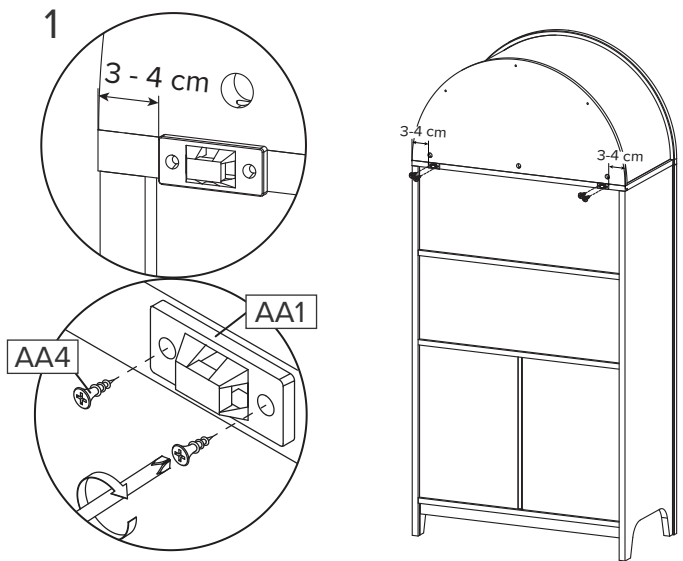

2. On the wall, measure at least 15mm below the height of bracket (AA1) that is on the product. Make a hole on the wall and install the wall plug (AA2).

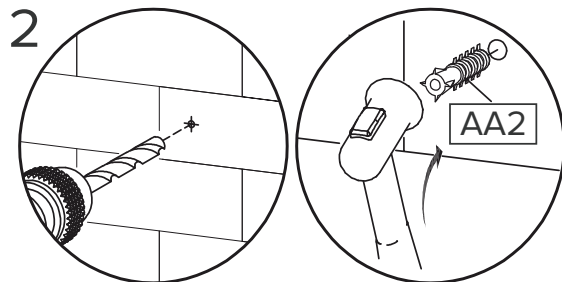

3. Locate the other bracket (AA1) on the wall plugs (AA2). Place furniture into position so both brackets (AA1) are vertically in the line.

4. Lace the end of the restraints straps through the larger hole in each bracket. Ensure the restraints strap with grids surface facing the inner loops.

Bring both ends together and slide the flat end through the locking end and draw through until all slack is removed.

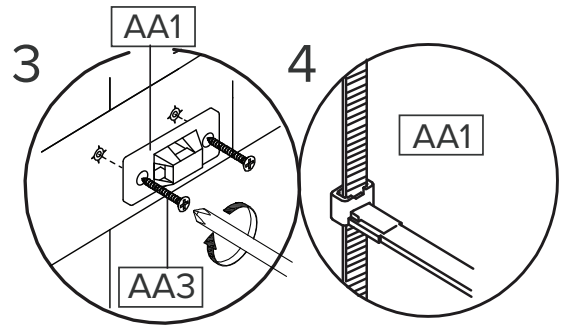

5. Make sure that the strap is securely laced & locked.



Please seek professional advice if unsure of wall constructions.

Properly affixing furniture to your wall will depend on the wall material: concrete, drywall, masonry, or wood will require the appropriate hardware.

Wall anchor and wall screw provided is suitable for concrete wall only.

please source the right wall anchor and wall screw according to the wall type. Please consult with your local hardware store to ensure you are using the correct hardware for your wall type.

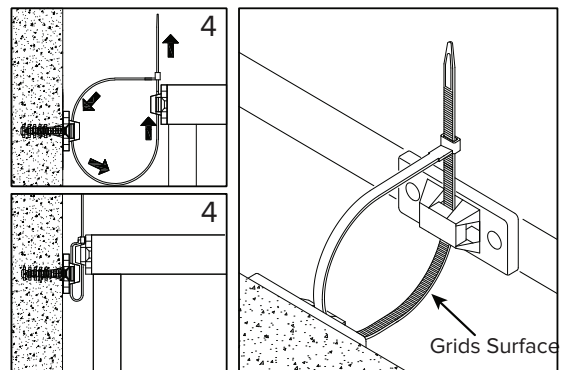

This anti-tip kit is not a substitute for proper adult supervision. This anti-tip kit may provide protection against tipping furniture.

Tips:

Teach and do not allow children to climb on furniture or drawers. Always keep the heavy load at the bottom of the drawer. Do not put toys or objects on the top that can attract children to climb.

By installing anti-tip kit, you acknowledge that you are fully aware of the safety requirement and accept to adhere to it. Illustrations in this guide are for reference only and may be slightly different from the actual object.

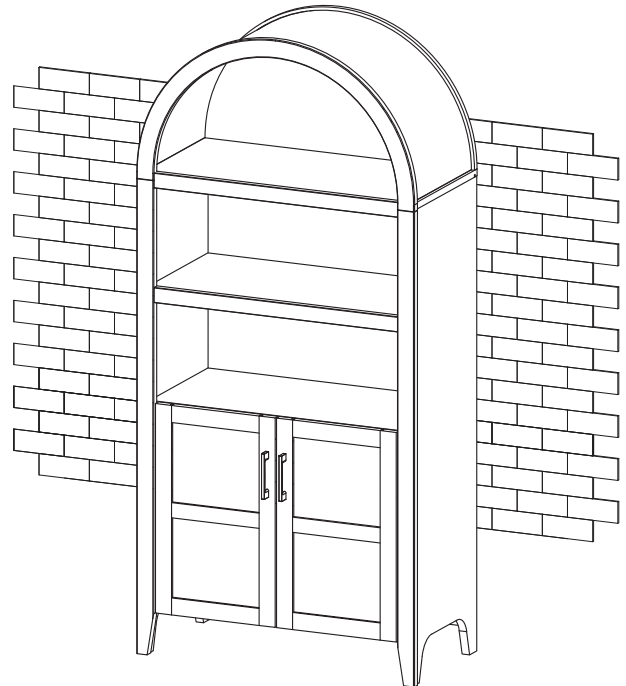

Care

Instructions

Your furniture, if treated with respect and love, will last you a long time. Each piece requires light maintenance to maximize its longevity.

Few quick tips before using this product:

1. Recommended weight limit for each storage compartment is 40lbs.
2. Avoid uneven weight distribution for long time as it may cause damage to the product shape.
3. Check and tighten the camlock and screw periodically as it may loose over the time.

How to take care of it?

1. Avoid direct sunlight or use curtains or blinds to limit the sun exposure to the product.
2. Clean the product regularly with a dry, soft cloth.
3. Avoid using abrasive or liquid cleanser.
4. We recommend always attaching the provided floor protector to the leg ends to protect your floor.

Follow the care instructions and look after your furniture, in return, your furniture will look after you.

We hope to see you soon!

Frequently Asked Questions

1. What should I do if my product received is incomplete?

Mopio products are flat packed and come in separate boxes. Once your order has dispatched and been sent with Fedex, you will receive an email with tracking information. Please note that Fedex may deliver your boxes in separate deliveries. Kindly follow the tracking information, allowing all boxes to be received before starting assembly. If you need further assistance on deliveries tracking, feel free to reach out to us at www.mopio.com#chat or help@mopio.com.

2. What should I do if my shipment is damaged or products received are defective?

We're sorry to hear that! Please email us at help@mopio.com or chat with us at www.mopio.com#chat and provide a detailed description of the damage, as well as photos (or videos, where appropriate) showing the damage. We will do our best to resolve the issue as soon as possible.

3. Can replacement parts be ordered?

Yes. Simply write to our customer service team at help@mopio.com or chat with us at www.mopio.com#chat, let us know your order ID and we will be happy to assist further.

4. Who do I contact for repair queries?

You may write to us at help@mopio.com specifying your queries and we will be able to assist you further.

5. What warranty do you offer for your products?

You'll just need to submit your warranty registration upon receiving product at www.mopio.com/warranty/register. You may provide your order ID or upload your order confirmation page as your proof of purchase. More details can be found in **Warranty section**.

6. How do I claim my warranty?

Easy! Just email us at help@mopio.com and provide a detailed description of the fault as well as photos.

7. What should I do if I want to return the product?

We offer a 30-day return policy upon product received. To initiate a return request, please contact our customer service team at help@mopio.com or www.mopio.com#chat with your reason of returning so we can facilitate the request and assist you further. For more details on the return policy, please refer to **Return section**.

Warranty & Return

1 YEAR LIMITED WARRANTY STATEMENT FOR MANUFACTURING DEFECTS

Please read this limited warranty carefully. To maintain your warranty, you will need to comply with the conditions stated here. This warranty is for manufacturing defects only and does not cover damages as a result of misuse.

1. Please be sure to register your product at www.mopio.com/warranty/register to activate your warranty. We recommend you doing so within 30 days upon receiving.
2. Your new product comes with 1-year warranty against manufacturing defects, upon activation. The warranty starts on the date of receipt. No warranty will be honored without a proof of purchase. The warranty and financial responsibility of the manufacturer only applies to the products itself.
3. Manufacturing defects include circumstances where the product has broken under normal use and no longer provides proper support. In the event you encounter a manufacturing defect, please stop using this product immediately and contact customer service.
4. This warranty applies only when the product has been properly used by consumers who purchased the product from authorized channels as a new product. Proper use means using the product on a level surface where all legs touch the floor with an equal distribution of weight. Proper use also means that the product was not abused by the consumer, as defined by the manufacturer. This warranty does not constitute agreement to replace other parts.
5. If the product fails due to manufacturing defects, the manufacturer will repair or replace at its discretion and reserves the right to substitute comparable materials or models and does not guarantee that the replacement part will match existing pieces.
6. In the event the product needs to be inspected by the manufacturer to determine a warranty claim, the transportation cost or removal cost is borne by the consumer.

MOPIO'S 30-DAY RETURN POLICY

We believe you will be thrilled with your purchase from Mopio. That's because we go out of our way to ensure that products are designed and built to be just what you need. We understand, however, that sometimes a product may not be what you expected it to be. In that event, we invite you to review the following terms related to returning a product.

The Return

Returns are to be made within 30 days of the date you received the product. To initiate return request, please message us or contact our customer service team at help@mopio.com or www.mopio.com#chat with your reason of returning so we can facilitate the request and issue return authorization to you. Please note the policy is subject to the conditions below:

1. Only undamaged items in original packaging will be accepted under the Returns Policy. Any items that are not returned to us in the original packaging and/or in original condition will incur an additional handling fee (deducted from your refund). It is your responsibility to package the item sufficiently to avoid damage in transit back to us. We encourage customers to photograph the items scheduled for return and the condition of the packaging before handing over to the delivery company.
2. We will not refund a product that you have bought and received where, in our reasonable opinion, the product has: become of unacceptable quality due to fair wear and tear; misuse; using it in an abnormal way; or failure to take reasonable care.
3. We will not be able to offer standard return policy after 30-day timeframe has passed. However, our customer service team is always an email away if you require further assistance with your Mopio products.

The Refund

We will assist you to complete the return process. We will perform standard inspection upon your return is received and will send you a message to acknowledge the return if item is presenting in original condition with original packaging.

You will be refunded the full amount less return shipping cost. Please note that while shipping charges on original deliveries are subsidized, on returns the full shipping amount paid by Mopio to the delivery partner will be deducted from your refund. **All refunds will take 2 business days to process upon return acknowledgement from us, however actual fund reversal date will depend on your card company's own processing schedule.**

Kindly note, in the event of returning a defective or damaged item, **we will however absorb the shipping charges and ensure your return/exchange experience is hassle free.**

The Exchange

We put quality as one of our top priorities – we work with experienced manufacturers and have every piece of Mopio product going through strict quality control process. We want to make sure your Mopio product reaches you safe and sound, however we are happy to do an exchange in case you receive a defective or damaged product due to any unforeseen hiccups throughout the journey. Please message us or email us at help@mopio.com with proof of defect or damage, our customer service will evaluate the exchange request, and assist you throughout the process accordingly.