

# Have Any Questions?

# mopio

Chat with us at [www.mopio.com#chat](https://www.mopio.com#chat) | We will be online from 10am to 7pm PST timing. Alternatively you can contact us at [help@mopio.com](mailto:help@mopio.com)

## Shop With Confidence



Norwin Executive Desk

I was able to organize some of Bryce's gaming equipment with the Norwin Executive Desk by @mopioinc! I always tell Bryce his rainbow equipment is cramping my neutral vibe  
- L



I am so very pleased with this coffee table. It looks great in our home and I love the nice walnut style. It was so easy to assemble and it's such good quality. The doors on both sides slide which the little kid in me was super entertained by. Highly recommend this piece!  
- L.D



Haylee Coffee Table

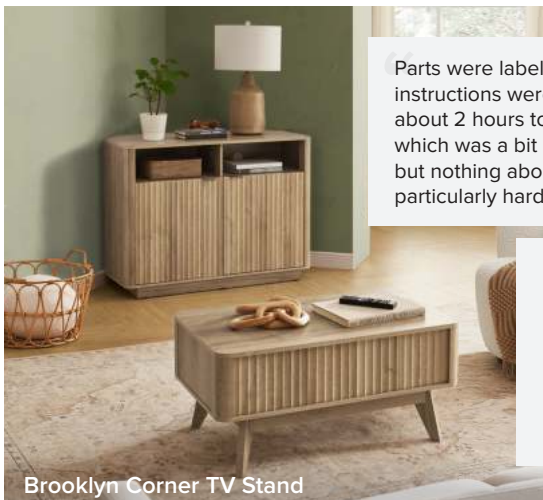

Brooklyn Corner TV Stand

Parts were labeled properly and the instructions were fairly clear. It took me about 2 hours to assemble on my own, which was a bit longer than I expected, but nothing about the assembly was particularly hard.

The colour of the oak laminate was in line with the pictures and the sizing was as described. All in all, it was value for money and it uplifted our living room with its waveform panel design and gave it the mid century modern touch I wanted.  
- L.L



# HAYLEE TV STAND, 46"

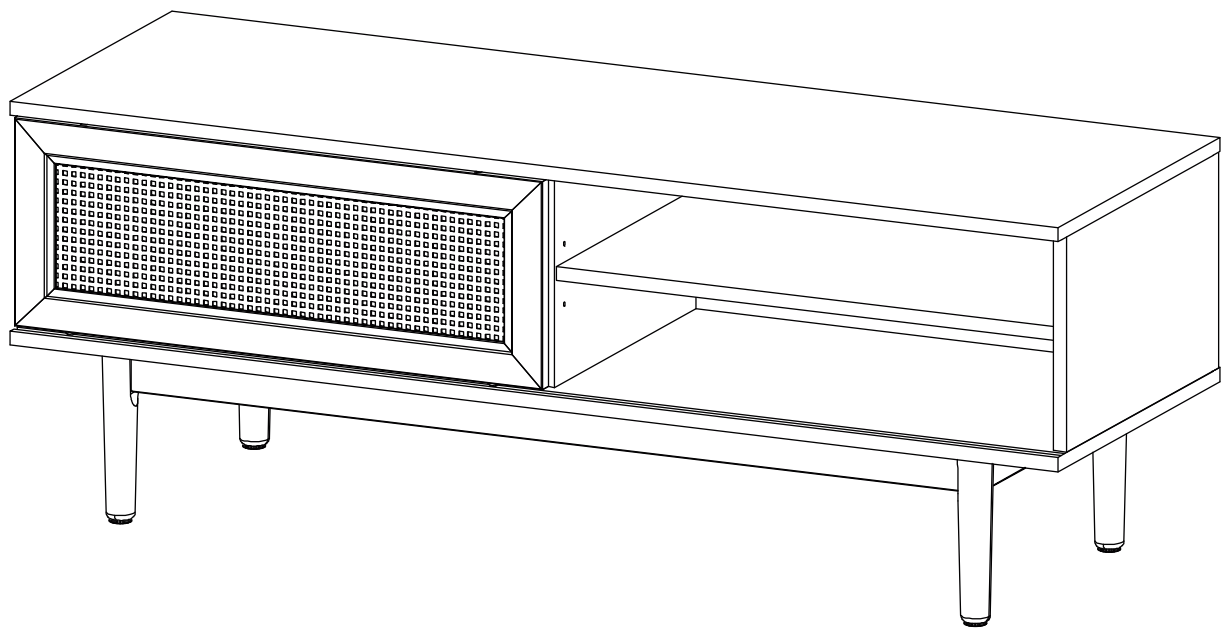

ASSEMBLY INSTRUCTIONS

**mopio**<sup>®</sup>

# Join Mopio Club and enjoy your 1-Year Warranty

We've got more for you. Be part of **Mopio Club** and enjoy:

- Privileged Customer Care
- 10% Off Your Next Purchase (no min spend)
- 1-Year Free Warranty
- Early Access To Upcoming Launches

To find out more: [www.mopio.com/club](http://www.mopio.com/club)



## Contact Us!

For any enquiries or issues regarding your purchase, chat with us  
at [www.mopio.com#chat](http://www.mopio.com#chat).

 [help@mopio.com](mailto:help@mopio.com)

  [@mopioinc](https://www.instagram.com/mopioinc)

 [www.mopio.com](http://www.mopio.com)

# Before you start...

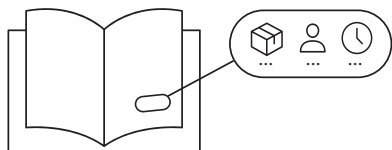

Ensure you have received all cartons and familiarize yourself with the workload. Make sure there are enough helping hands to assist you, and that you have allocated the time required to assemble your new product.

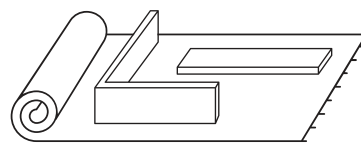

Make sure you have cleared enough space in your home for the assembly. We recommend protecting your floor with a mat or cardboard to avoid scratches during the assembly process.

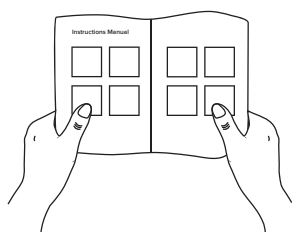

Read instructions carefully and check no parts are missing.

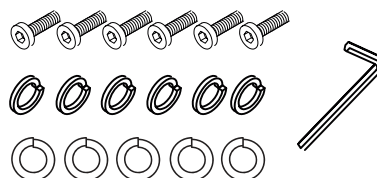

Lay out all hardware on a soft surface so you can easily identify them.

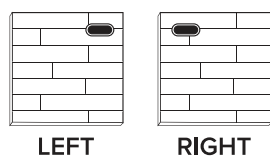

Carefully identify all components in order to differentiate which pieces are left and right.



Install your new product carefully following the instructions. Don't skip ahead!

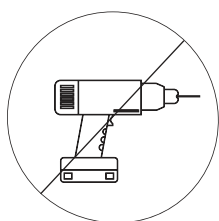

**DO NOT** over tighten screws or use a drill. It will damage the product.



If you need further assistance with assembling your Mopio product, please chat with us at [www.mopio.com#chat](https://www.mopio.com#chat).

# Parts





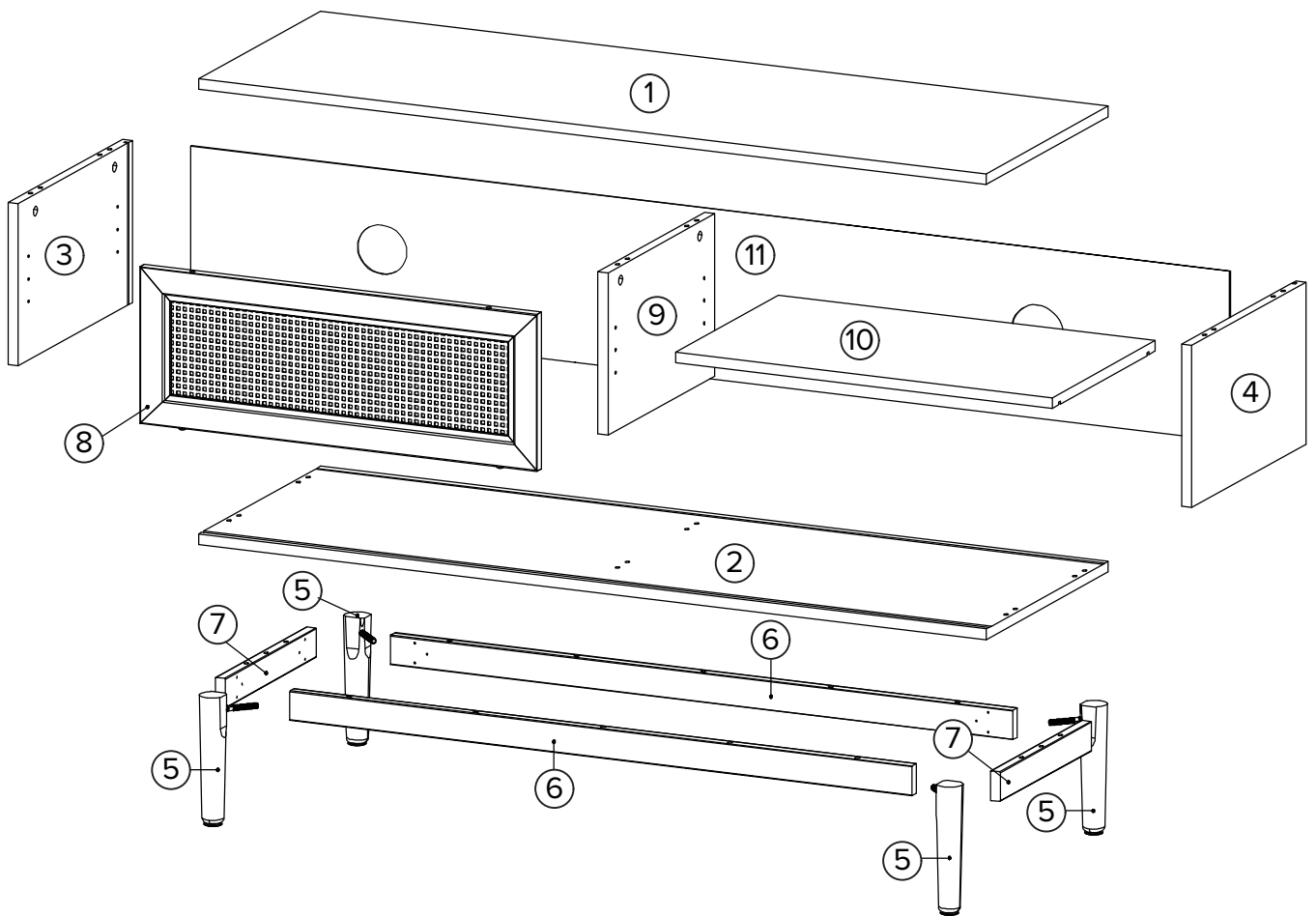



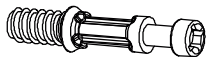
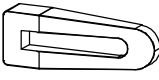

▶ Watch installation demo video at:  
<https://bit.ly/381LCAV>



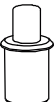
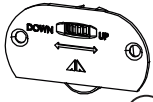
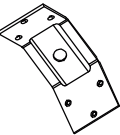
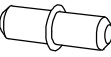
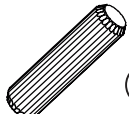
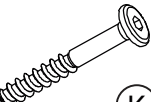

- ① x1
- ② x1
- ③ x1
- ④ x1
- ⑤ x4
- ⑥ x2
- ⑦ x2
- ⑧ x1
- ⑨ x1
- ⑩ x1
- ⑪ x1

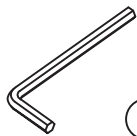
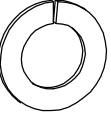
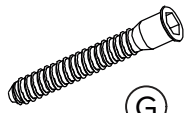



# Hardware



**Watch installation demo video at:**  
<https://bit.ly/381LCAV>

- |                          |   |                                     |                          |   |  |                          |   |  |
|--------------------------|---|-------------------------------------|--------------------------|---|--|--------------------------|---|--|
| <input type="checkbox"/> |    | Cambolt<br>Ø 6 x 35 mm<br><b>x6</b> | <input type="checkbox"/> |    | Stopper<br><b>x2</b>                   | <input type="checkbox"/> |    | Screw Cup<br>Ø 15 mm<br><b>x6</b>      |
| <input type="checkbox"/> |    | Camlock<br>Ø 15 mm<br><b>x6</b>     | <input type="checkbox"/> |    | Screw<br>M 4.5 x 12.5 mm<br><b>x24</b> | <input type="checkbox"/> |    | Pin Sliding<br>Top<br><b>x2</b>        |
| <input type="checkbox"/> |    | Sliding<br>Bottom<br><b>x2</b>      | <input type="checkbox"/> |    | Corner<br>Brace<br><b>x4</b>           | <input type="checkbox"/> |    | Shelf Pin<br>Ø 5 x 15 mm<br><b>x4</b>  |
| <input type="checkbox"/> |    | Dowel<br>Ø 8 x 30 mm<br><b>x18</b>  | <input type="checkbox"/> |    | Screw<br>M 6.4 x 53 mm<br><b>x10</b>   | <input type="checkbox"/> |    | Wedge<br><b>x12</b>                    |
| <input type="checkbox"/> |  | Screw<br>M 3.5 x 13 mm<br><b>x4</b> | <input type="checkbox"/> |  | Nut<br><b>x4</b>                       | <input type="checkbox"/> |  | Screw<br>M 3.5 x 15.5 mm<br><b>x12</b> |
| <input type="checkbox"/> |  | Allen Key<br>L 4<br><b>x1</b>       | <input type="checkbox"/> |  | Ring<br>Per<br><b>x4</b>               |                          |   |  |
| <input type="checkbox"/> |  | Screw<br>M 7 x 50 mm<br><b>x6</b>   | <input type="checkbox"/> |  | Key<br><b>x1</b>                       |                          |   |  |

-  There are inner box(es) that include components required to complete this assembly.
-  Please do not completely tighten all the hardware, until each assembly step is complete.
-  Before discarding the packaging, please use the checklist to ensure that you have all the parts required to assemble your product. Please kindly note you will need the original package if you want to return the product later.
-  If parts are missing or damaged, we will gladly ship your replacements parts free of charge. Please contact us at [help@mopio.com](mailto:help@mopio.com) or chat with us at [www.mopio.com#chat](https://www.mopio.com#chat).

  
**x1**

  
**x2**

  
**60 mins**

# Step 1

Ensure your floor is properly protected, then take out board No. 1, No.3, No. 4, No. 9. Screw cambolt A to board No. 1 (don't over screw). Plug in dowel D into side holes of board No.3, No. 4, No. 9.

Please ensure you screw or plug into the correct hole according to the illustration.

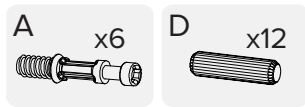
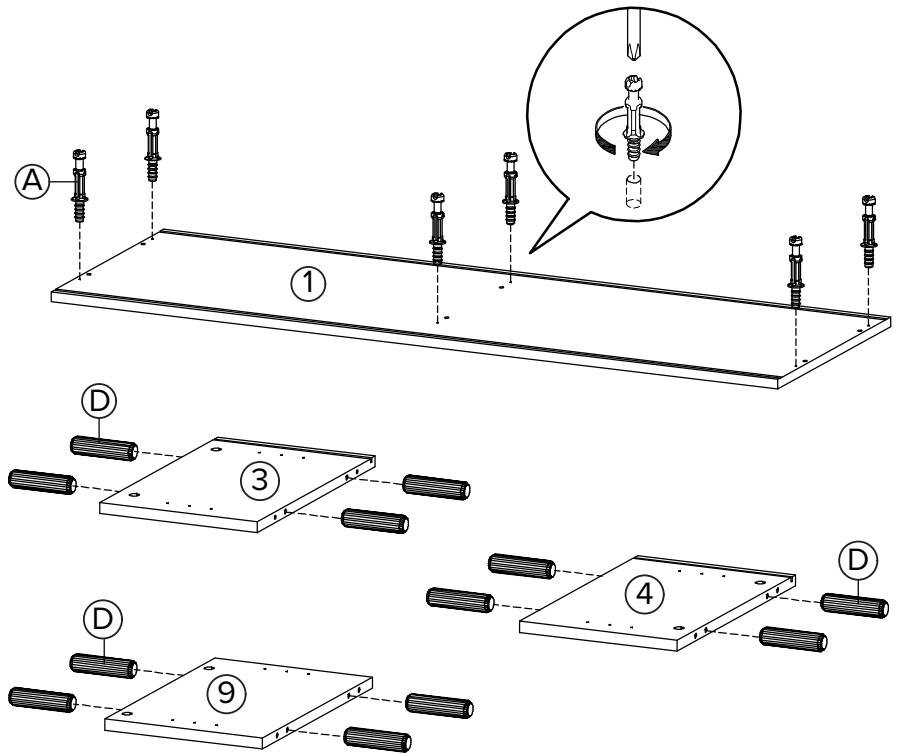

# Step 2

Install board No.3, No. 4, No. 9 onto board No1. by inserting camlock B and tightening it with Allen key provided or screwdriver.

Plug in cover cap O to hide the screw.

Please ensure the correct orientation for board No.3, No. 4, No. 9 and the camlock placing orientation. Refer to illustration carefully.

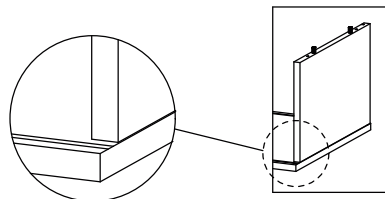
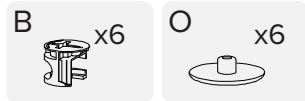
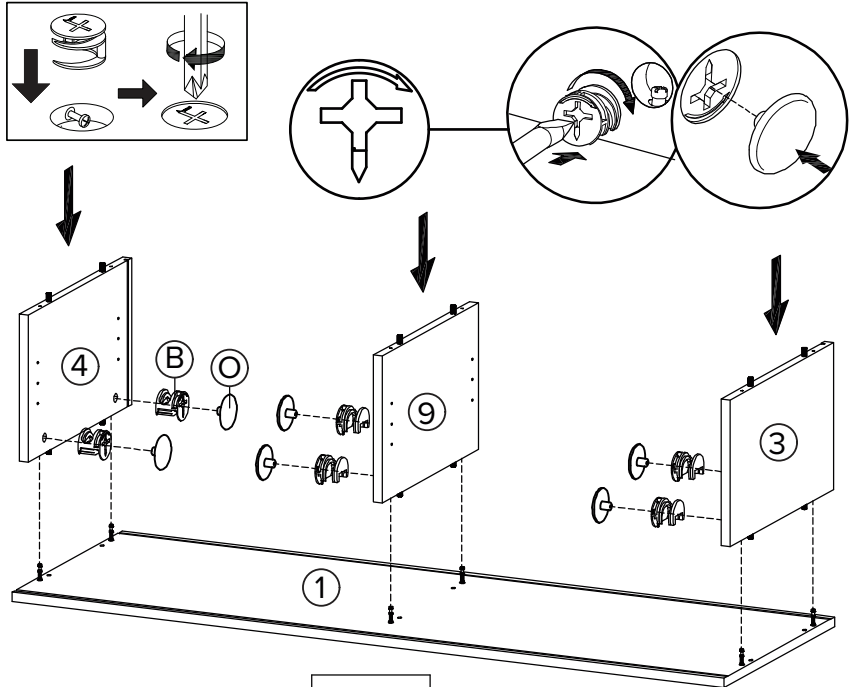

Please take note that the grooves found on board 1 must face the front.

**Missing parts? Or feeling stuck?**  
Chat with us at [www.mopio.com/#chat](https://www.mopio.com/#chat)

**Watch demo video at:**  
<https://bit.ly/381LCAV>

# Step 3

Slide in board 11 into the grooves. If it doesn't match, please refer to Step no 2.

Place board 2 on top, align it with the holes indicated and insert screws (G) accordingly, tightening it with the tool F.

Do make sure that all screws are engaged and screwed in properly before fully tightening it.

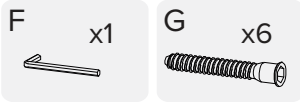
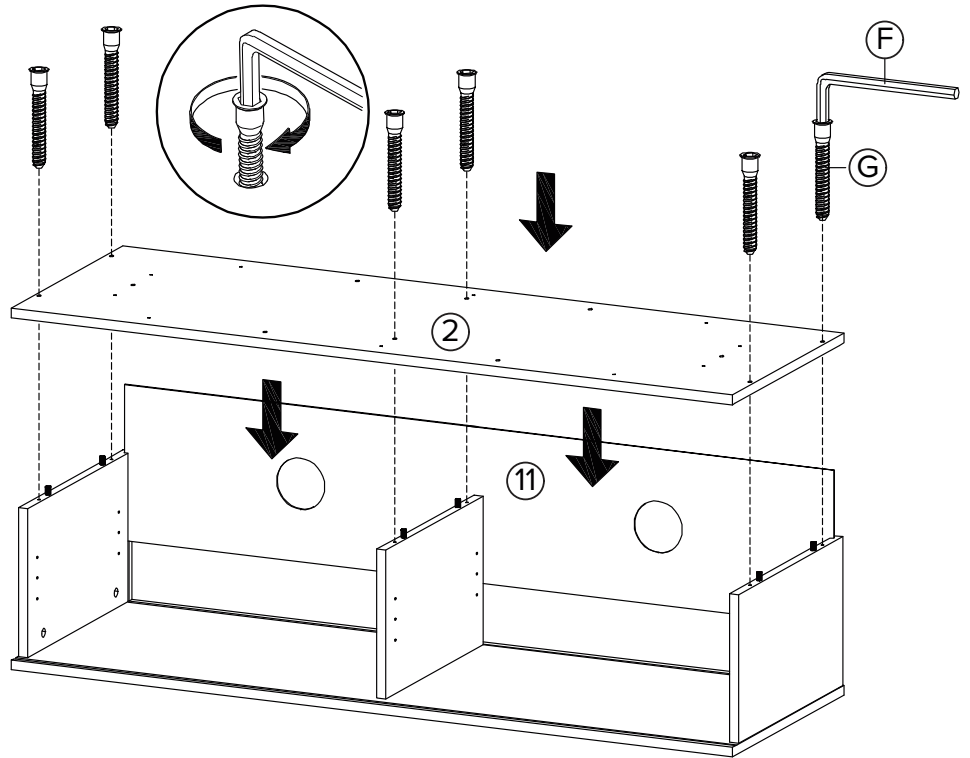

# Step 4

Prepare leg frame 7 (2pcs) and install bracket (J) with screw (I).

Do not fully tighten the screw (leave about 2mm), you will tighten it on step 9.

Refer to illustration for bracket placement orientation.

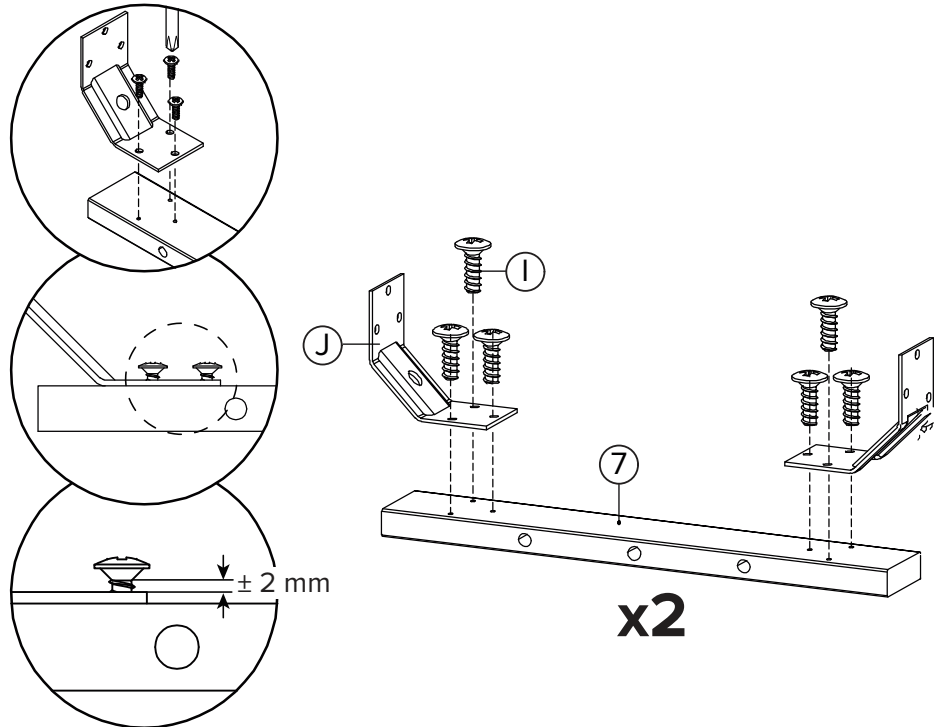

**Missing parts? Or feeling stuck?**  
Chat with us at [www.mopio.com/#chat](https://www.mopio.com/#chat)

**Watch demo video at:**  
<https://bit.ly/381LCAV>



# Step 5

Prepare leg frame 6 and connect with leg frame 7 (2 pcs) according to the diagram.

Do not fully tighten the screw (leave about 2mm), you will tighten it on step 9.

Refer to illustration for bracket placement orientation.

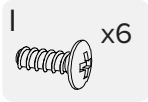
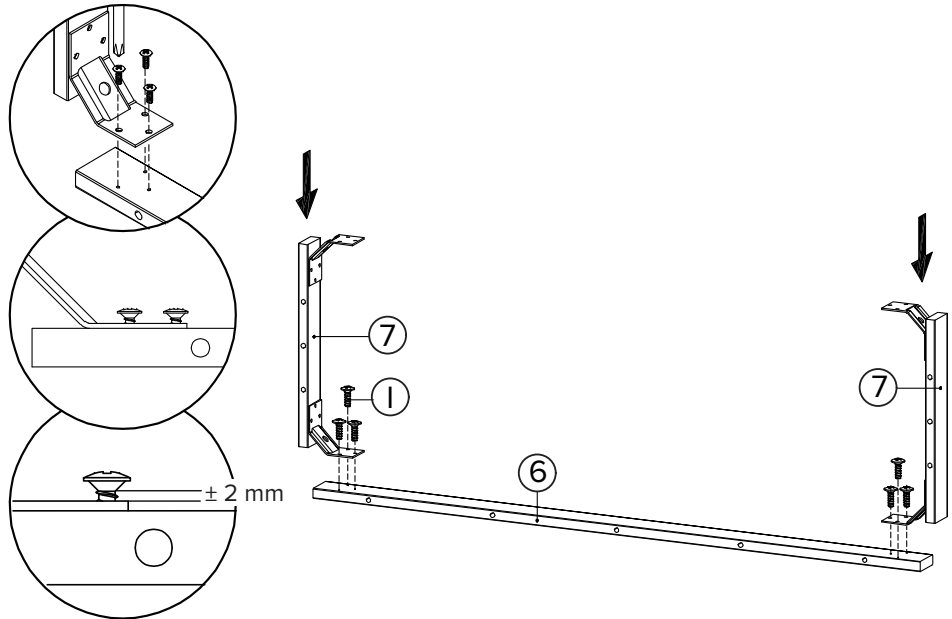

# Step 6

Prepare another leg frame 6 and connect it with leg frame 7 (2 pcs) according to the diagram.

Do not fully tighten the screw (leave about 2mm), you will tighten it on step 9

Refer to illustration for bracket placement orientation.

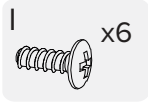
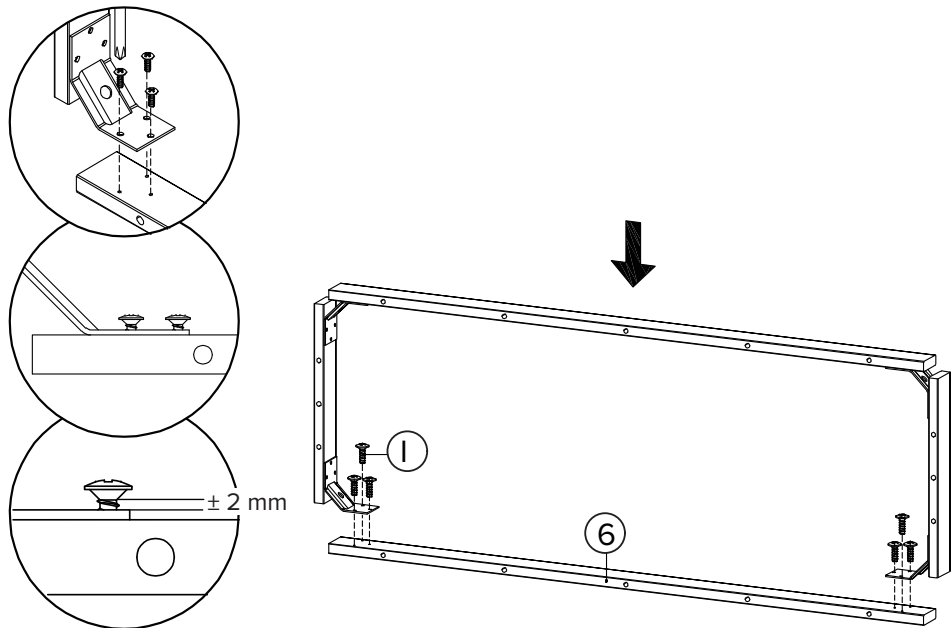

# Step 7

Plug in dowel (D) into the holes found on the leg frames.

Refer to illustration carefully for dowel hole positions.

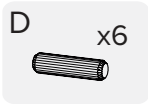
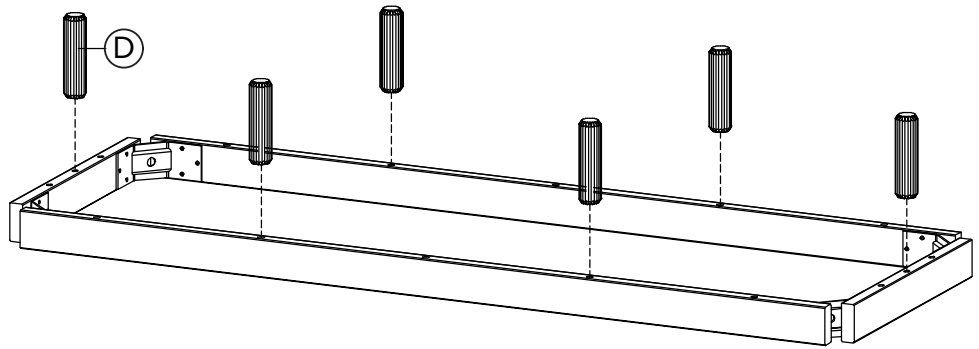

# Step 8

This step may require an extra pair of hands to complete.

Position leg frame upside down and install it to board 2.

Insert screw K into the bracket found on leg frame and tighten screws accordingly with tool F.

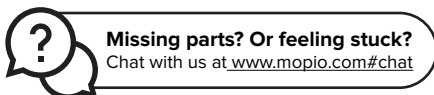
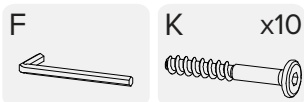
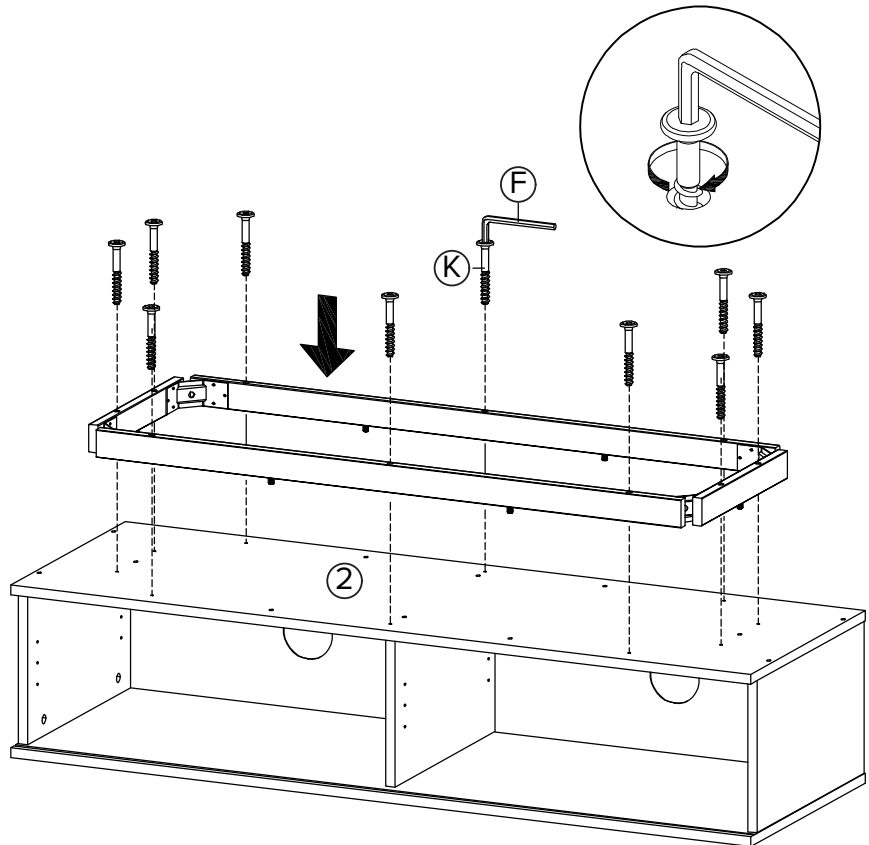

Missing parts? Or feeling stuck?  
Chat with us at [www.mopio.com/#chat](https://www.mopio.com/#chat)

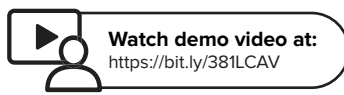

Watch demo video at:  
<https://bit.ly/381LCAV>

# Step 9

Prepare leg no.5 (4pcs).  
Remove the screw protectors.

Slot in leg No. 5 (4pcs) by matching the screws position and inserting fully. Insert washer M and nuts L into each screws and tighten with wrench N.

Tighten all the screws on the leg frame as indicated on detail 2.

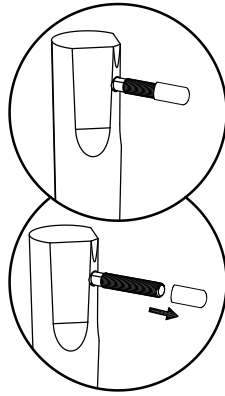

Detail 1

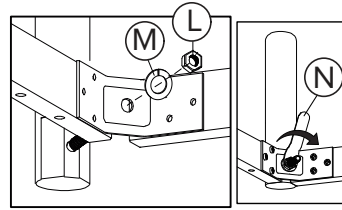

Detail 2

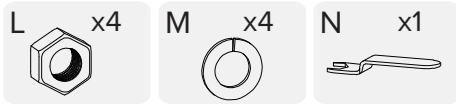
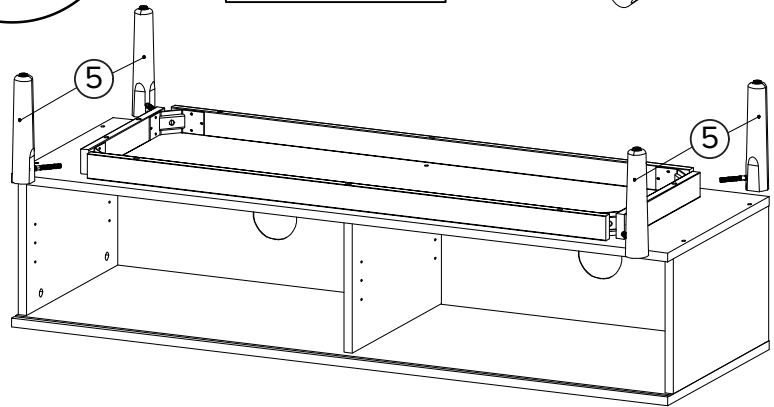
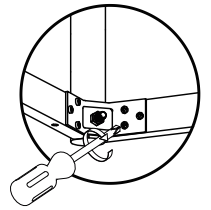

# Step 10

Plug in shelf support Q into the desired hole positions. Place the shelves gently on top of the shelf pins.

The shelf board is adjustable and can be placed on either the left or right side.

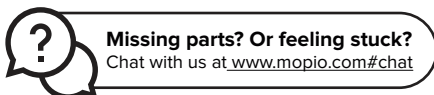
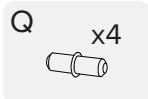
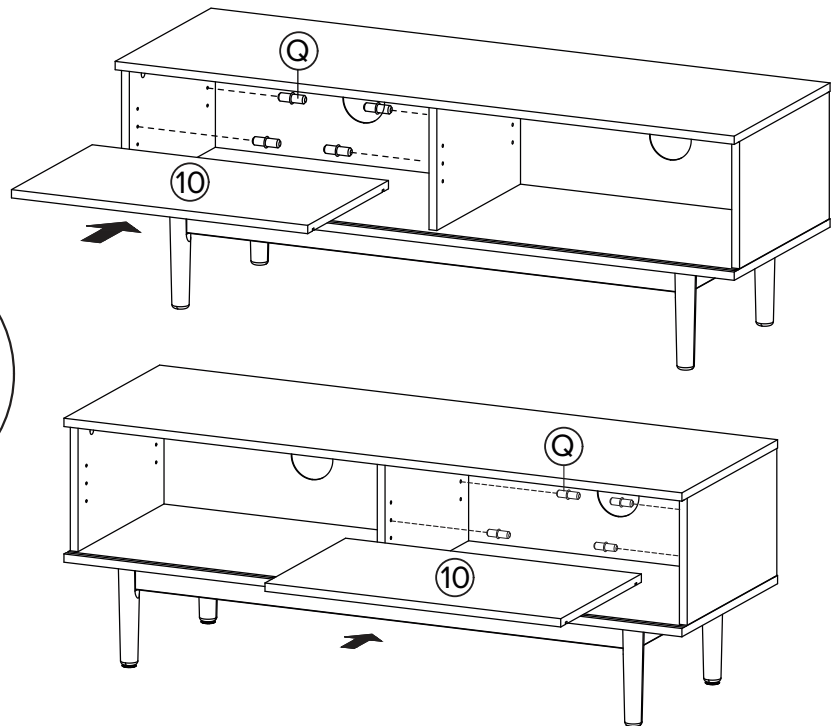
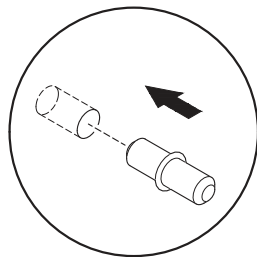

Missing parts? Or feeling stuck?  
Chat with us at [www.mopio.com/#chat](https://www.mopio.com/#chat)

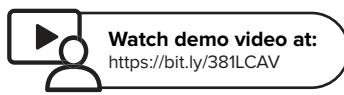

Watch demo video at:  
<https://bit.ly/381LCAV>

# Step 11

Please check the illustration and identify the correct position of pin sliding.

Prepare Door No.8 (2pcs).  
Install sliding roller C with screw E. Insert the pin P onto side hole as indicated on the illustration.

Plug in stopper H, please refer to illustration to ensure that orientation is correct.

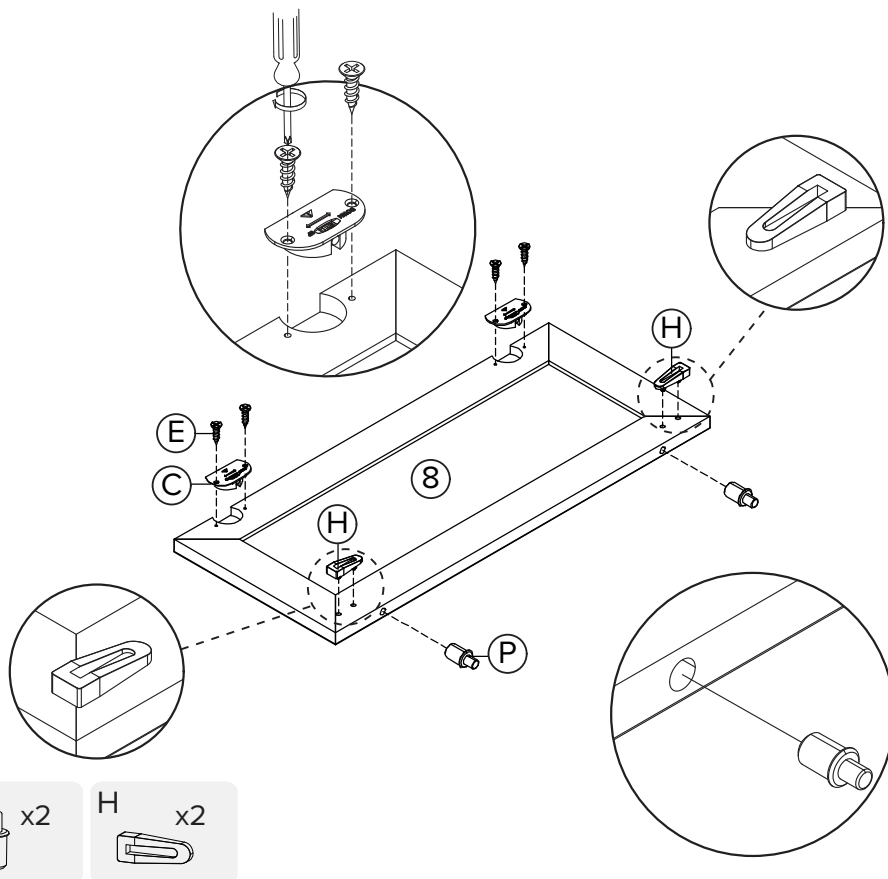

# Step 12

Reverse the table body and let it stand upwards to install the sliding door. You may need extra pair of hands to reverse the table body.

Insert the door panel's top sliding pin to the groove underneath the tabletop. While holding its position, insert the bottom sliding roller to the groove at the bottom board. When all pins are in the right position completely, release the door.

If there is any misaligned gap or difficulty in sliding, you may adjust the sliding roller to your preferred position.

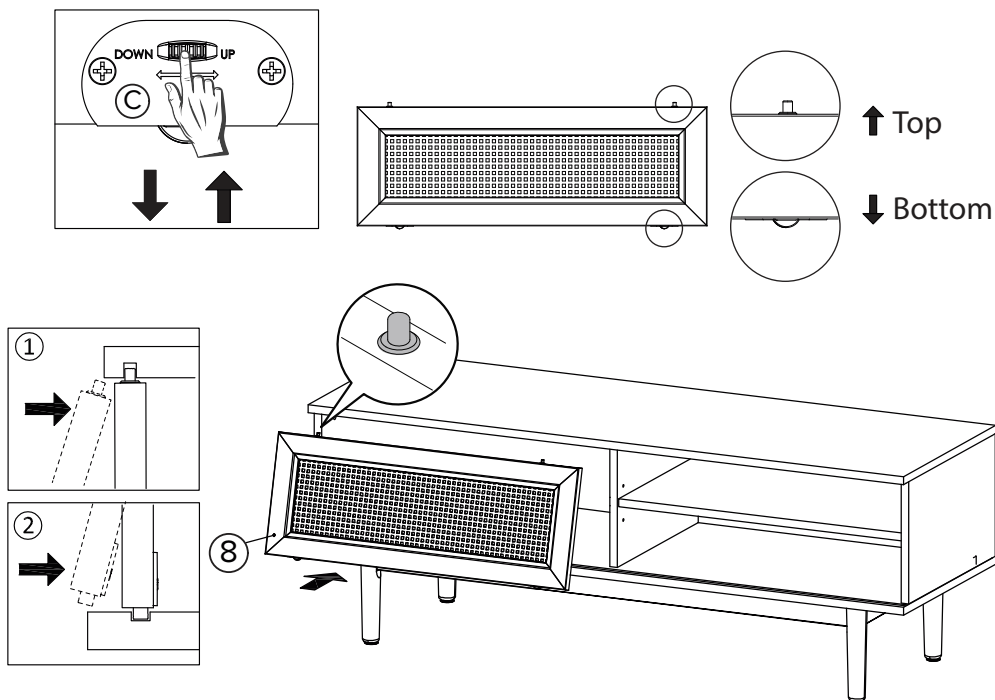

**Missing parts? Or feeling stuck?**  
Chat with us at [www.mopio.com/chat](https://www.mopio.com/chat)

**Watch demo video at:**  
<https://bit.ly/381LCAV>

# Step 13

Slide in back board stopper R onto the back panel groove as indicated on the drawing.

Check carefully the product assembly before tightening it, ensure that the body installation is square (perpendicular 90 degree).

Tighten with screw S using screw driver.

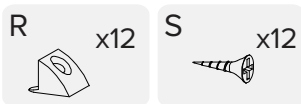
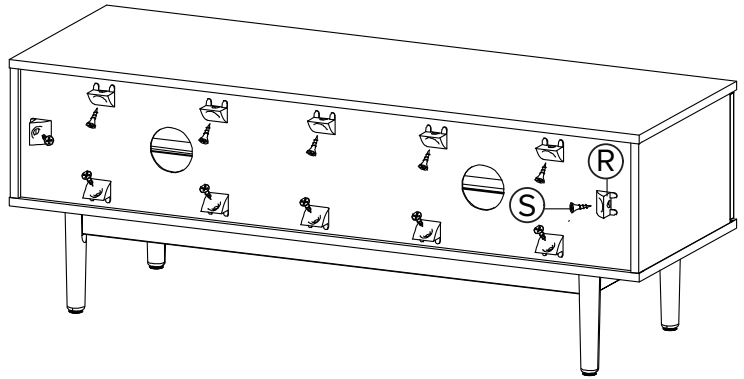
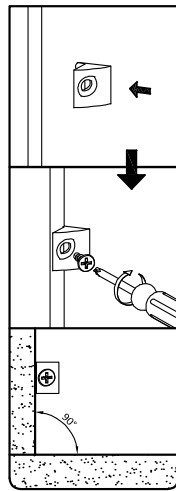

# Step 14

In the event of imbalance, adjust the leveler on each leg accordingly.

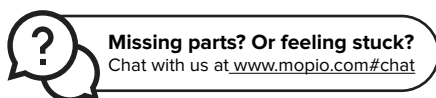
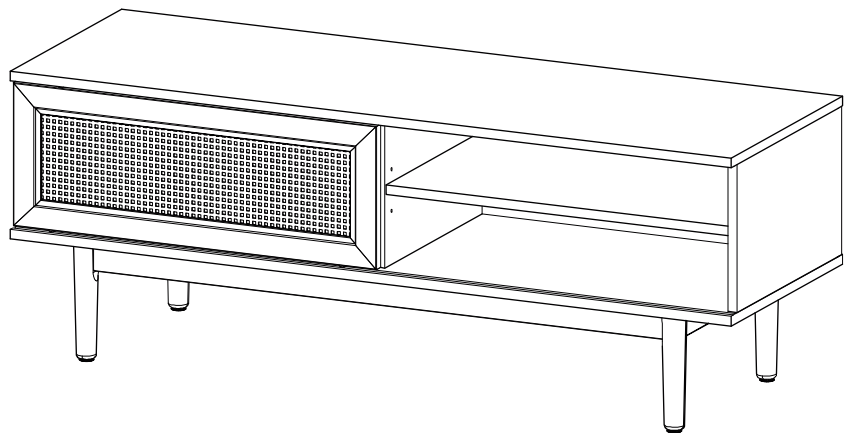
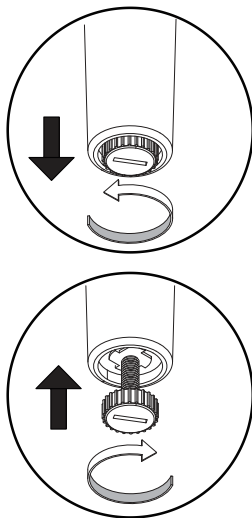

# Finished!

---

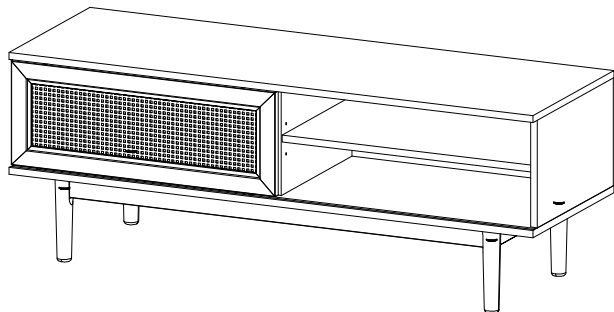

**Congratulations! We're almost there! Please perform following checks to ensure assembly is properly done.**

- Ensure all legs frame are fully tightened, please refer to Step 9.
- If the door's gap is misaligned, please refer to Step 12.
- If the product is imbalance, please refer to Step 14.

**Move your Mopio product carefully, with 2 people lifting it to the preferred location. Clean the product with a dry cloth. You are all set!**

**Enjoy your fresh and updated living space thanks to the addition of your new Mopio product!**

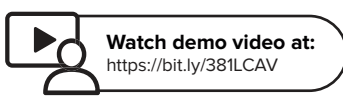
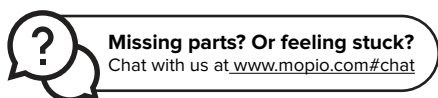

# Care

## Instructions

Your furniture, if treated with respect and love, will last you a long time. Each piece requires light maintenance to maximize its longevity.

### **Few quick tips before using this product:**

1. Recommended weight limit for the table top is 40lbs and 15lbs for each storage compartment.
2. Avoid uneven weight distribution for long time as it may cause damage to the product shape.
3. Sliding door might not slide smoothly when table is overloaded by weight.
4. Check and tighten the camlock and screw periodically as it may loose over the time.

### **How to take care of it?**

1. Avoid direct sunlight or use curtains or blinds to limit the sun exposure to the product.
2. Clean the product regularly with a dry, soft cloth.
3. Avoid using abrasive or liquid cleanser.
4. We recommend always attaching the provided floor protector to the leg ends to protect your floor.
5. Avoid placing hot objects onto the table top surface.
6. Spillage may damage the surface. Clean immediately with a dry cloth.
7. We recommend using placemats or coasters underneath glasses, cups, bowls or plates to prevent scratches to the table surface.

Follow the care instructions and look after your furniture, in return, your furniture will look after you.

We hope to see you soon!

# Frequently Asked Questions

## 1. What should I do if my product received is incomplete?

Mopio products are flat packed and come in separate boxes. Once your order has dispatched and been sent with Fedex, you will receive an email with tracking information. Please note that Fedex may deliver your boxes in separate deliveries. Kindly follow the tracking information, allowing all boxes to be received before starting assembly. If you need further assistance on deliveries tracking, feel free to reach out to us at [www.mopio.com#chat](http://www.mopio.com#chat) or [help@mopio.com](mailto:help@mopio.com).

## 2. What should I do if my shipment is damaged or products received are defective?

We're sorry to hear that! Please email us at [help@mopio.com](mailto:help@mopio.com) or chat with us at [www.mopio.com#chat](http://www.mopio.com#chat) and provide a detailed description of the damage, as well as photos (or videos, where appropriate) showing the damage. We will do our best to resolve the issue as soon as possible.

## 3. Can replacement parts be ordered?

Yes. Simply write to our customer service team at [help@mopio.com](mailto:help@mopio.com) or chat with us at [www.mopio.com#chat](http://www.mopio.com#chat), let us know your order ID and we will be happy to assist further.

## 4. Who do I contact for repair queries?

You may write to us at [help@mopio.com](mailto:help@mopio.com) specifying your queries and we will be able to assist you further.

## 5. What warranty do you offer for your products?

You'll just need to submit your warranty registration upon receiving product at [www.mopio.com/warranty/register](http://www.mopio.com/warranty/register). You may provide your order ID or upload your order confirmation page as your proof of purchase. More details can be found in **Warranty section**.

## 6. How do I claim my warranty?

Easy! Just email us at [help@mopio.com](mailto:help@mopio.com) and provide a detailed description of the fault as well as photos.

## 7. What should I do if I want to return the product?

We offer a 30-day return policy upon product received. To initiate a return request, please contact our customer service team at [help@mopio.com](mailto:help@mopio.com) or [www.mopio.com#chat](http://www.mopio.com#chat) with your reason of returning so we can facilitate the request and assist you further. For more details on the return policy, please refer to **Return section**.



# Warranty & Return

## **1 YEAR LIMITED WARRANTY STATEMENT FOR MANUFACTURING DEFECTS**

Please read this limited warranty carefully. To maintain your warranty, you will need to comply with the conditions stated here. This warranty is for manufacturing defects only and does not cover damages as a result of misuse.

1. Please be sure to register your product at [www.mopio.com/warranty/register](http://www.mopio.com/warranty/register) to activate your warranty. We recommend you doing so within 30 days upon receiving.
2. Your new product comes with 1-year warranty against manufacturing defects, upon activation. The warranty starts on the date of receipt. No warranty will be honored without a proof of purchase. The warranty and financial responsibility of the manufacturer only applies to the products itself.
3. Manufacturing defects include circumstances where the product has broken under normal use and no longer provides proper support. In the event you encounter a manufacturing defect, please stop using this product immediately and contact customer service.
4. This warranty applies only when the product has been properly used by consumers who purchased the product from authorized channels as a new product. Proper use means using the product on a level surface where all legs touch the floor with an equal distribution of weight. Proper use also means that the product was not abused by the consumer, as defined by the manufacturer. This warranty does not constitute agreement to replace other parts.
5. If the product fails due to manufacturing defects, the manufacturer will repair or replace at its discretion and reserves the right to substitute comparable materials or models and does not guarantee that the replacement part will match existing pieces.
6. In the event the product needs to be inspected by the manufacturer to determine a warranty claim, the transportation cost or removal cost is borne by the consumer.

## **MOPIO'S 30-DAY RETURN POLICY**

We believe you will be thrilled with your purchase from Mopio. That's because we go out of our way to ensure that products are designed and built to be just what you need. We understand, however, that sometimes a product may not be what you expected it to be. In that event, we invite you to review the following terms related to returning a product.

## The Return

Returns are to be made within 30 days of the date you received the product. To initiate return request, please message us or contact our customer service team at [help@mopio.com](mailto:help@mopio.com) or [www.mopio.com#chat](https://www.mopio.com#chat) with your reason of returning so we can facilitate the request and issue return authorization to you. Please note the policy is subject to the conditions below:

1. Only undamaged items in original packaging will be accepted under the Returns Policy. Any items that are not returned to us in the original packaging and/or in original condition will incur an additional handling fee (deducted from your refund). It is your responsibility to package the item sufficiently to avoid damage in transit back to us. We encourage customers to photograph the items scheduled for return and the condition of the packaging before handing over to the delivery company.
2. We will not refund a product that you have bought and received where, in our reasonable opinion, the product has: become of unacceptable quality due to fair wear and tear; misuse; using it in an abnormal way; or failure to take reasonable care.
3. We will not be able to offer standard return policy after 30-day timeframe has passed. However, our customer service team is always an email away if you require further assistance with your Mopio products.

## The Refund

We will assist you to complete the return process. We will perform standard inspection upon your return is received and will send you a message to acknowledge the return if item is presenting in original condition with original packaging.

You will be refunded the full amount less return shipping cost. Please note that while shipping charges on original deliveries are subsidized, on returns the full shipping amount paid by Mopio to the delivery partner will be deducted from your refund. **All refunds will take 2 business days to process upon return acknowledgement from us, however actual fund reversal date will depend on your card company's own processing schedule.**

Kindly note, in the event of returning a defective or damaged item, **we will however absorb the shipping charges and ensure your return/exchange experience is hassle free.**

## The Exchange

We put quality as one of our top priorities – we work with experienced manufacturers and have every piece of Mopio product going through strict quality control process. We want to make sure your Mopio product reaches you safe and sound, however we are happy to do an exchange in case you receive a defective or damaged product due to any unforeseen hiccups throughout the journey. Please message us or email us at [help@mopio.com](mailto:help@mopio.com) with proof of defect or damage, our customer service will evaluate the exchange request, and assist you throughout the process accordingly.