

Oliveri®

Model: SS2515

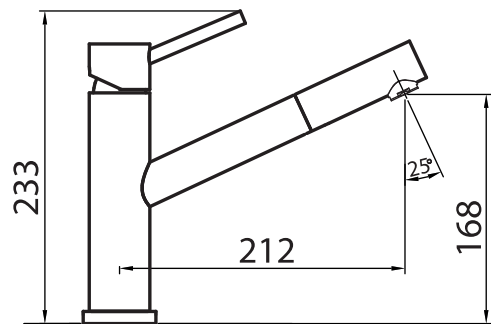

FEATURES AND BENEFITS

- **WELS 4 star rating**
4 Star water efficiency rating, 7.5L per minute.
- **Stainless steel**
Modern design and durable finish to suit all kitchens.
- **10 year warranty**
Covered by Oliveri's 10 year warranty (5 years parts & labour plus an additional 5 years parts only).
- **Filtered water**
Connect an Oliveri inline filtration system to any Essente mixer to enjoy fresh tasting water in your home.
- **Watermark**
Oliveri mixers carry the Watermark logo, confirming they comply with Australian standards.

OTHER MODELS YOU MAY LIKE

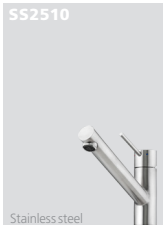

MATCHING ACCESSORIES



SPECIFICATIONS

Description

Oliveri Essente stainless steel swivel pull out mixer

Mixer Height

233 mm

WELS Rating

4 star water efficiency
7.5L per minute

Finish	Stainless steel
Cartridge Size	35 mm
Cartridge Type	Ceramic disc
EAN	9324974012212
Spout height	168 mm
Max. operating pressure	500 kpa
Carton Size	500 x 310 x 75 mm
Weight	3 kg
Warranty	10 Year Warranty: 5 years only (parts & labour) plus an additional 5 years on the Cartridge (parts only) Refer to oliveri.com.au for full warranty details



For more information call **1300 137 465** or visit oliveri.com.au