

ILVE COMMERCIAL

MULTI-RESIDENTIAL & HOME BUILDER PRODUCT RANGE



IVDFI400 60CM FULLY-INTEGRATED DISHWASHER



MODEL IVDFI400 FULLY-INTEGRATED DISHWASHER

STYLE

- Fully-Integrated

CAPACITY

- 13 place settings

FEATURES

- 6 wash programs- Mini 14' (Jet Wash), Quick 30' 40°C, eco, Super 50' 65°C (Quick Clean), Hygiene 60°C, Auto Intensive 65°C
- hidden heating element
- stainless steel tub
- smart wash function
- ECO Wash - Half load option
- turbo drying system
- overflow & leaking protection
- heater protection
- Asynchronous Circulation pump
- mesh upper basket
- Adjustable upper basket, 4 adjustable mug shelves
- Fold-able racks on lower basket, Removable cutlery basket
- Wine stem support & Spoon rack on upper basket
- Noise Level 45 (dB(A))

CONTROL PANEL & USER INTERFACE BUTTONS

- LED display
- delay timer option
- tablet option
- Rinse-aid indicator
- end of wash bell
- touch control

TECHNICAL

- 3 star energy rating
- 4 star water rating
- 12.8L Water consumption
- power cord length- 165cm
- Water inlet hose length- 155cm
- Water outlet hose length- 170cm



ILVE COMMERCIAL

MULTI-RESIDENTIAL & HOME BUILDER PRODUCT RANGE

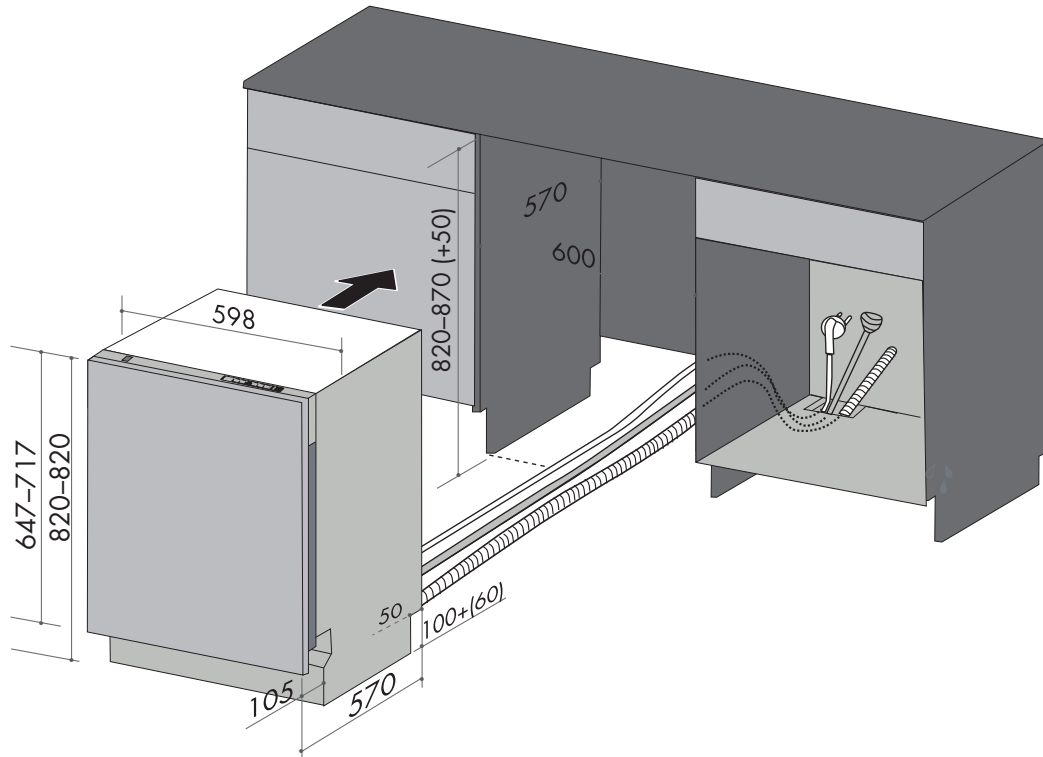

IVDFI400 60CM FULLY-INTEGRATED DISHWASHER

Dishwasher
EAN code: 9347777003232 (IVDFI400)

 Product Size: W598mm x D550mm x H820mm
 (adjustable 5cm)

 NB: drawings are not to scale —
 they are to be used as a guide only

FOLLOW US:

/ilve_appliances/



/ILVEappliances



/ILVE_appliances



/ILVEappliances

 Page 2/2
 25052020

 Australia National Telephone Number 1300 MYILVE (694 583) New Zealand Telephone Number 0508 458 369
 ILVE showrooms are open daily from 9am-5pm and Saturdays 10am-4pm

ilve.com.au
NSW & ACT (Head Office)

 48-50 Moore Street
 Leichhardt
 F 02 8569 4699

VIC & SA

 1211 Toorak Road
 Camberwell
 F 03 9809 2155

QLD

 1/42 Cavendish Road
 Coorparoo
 F 07 3397 0850

WA & NT

 Unit 10/55 Howe Street
 Osborne Park
 F 08 9201 9188

New Zealand

 PO Box 11.160
 Sockburn Christchurch
 F 03 344 5906

DISCLAIMER
 Eurolinx PTY LTD, trading as ILVE Appliances, is continually seeking ways to improve the design specifications, aesthetics and production techniques of its products. As a result alterations to our products and designs take place continually. Whilst every effort is made to produce information and literature that is up to date, this brochure should not be regarded as an infallible guide to the current specifications, nor does it constitute an offer for the sale of any particular product. Product dimensions indicated in our literature is indicative only. Actual product only should be used to define dimension cutouts. Distributors, and retailers are not agents of ILVE Appliances and are not authorized to bind ILVE Appliances by any express or implied undertaking or representation.