

ILVE COMMERCIAL MULTI-RESIDENTIAL & HOME BUILDER PRODUCT RANGE

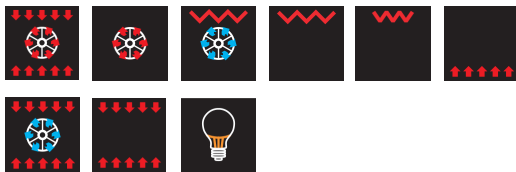

ILO60DCX 60CM ELECTRIC BUILT-IN OVEN



S-move soft & gentle closing door hinges



ILO60DCX BUILT-IN ELECTRIC OVEN

FEATURES

- tangential fan cooling
- Time, 24h setting
- Touch control digital timer
- Accurate digital thermostat control: 0°C-250°C
- S-MOVE Soft close hinges
- Inner door with 'American' Style robust commercial design

FINISH

- ANTI-fingerprint AS430 stainless steel

SAFETY

- Cool touch triple glazed glass door

FUNCTIONS

- 9 functions — pizza, fan forced, fan grill, static grill, half static grill, bottom element, fan assisted, convection, light

CLEANING

- ULTRA-Clean smooth black cavity
- easy-clean removable inner glass & door

CAPACITY & INTERIOR

- Oven cavity size (cm): 46w x 41.5d x 35.2h
- 5 cooking levels
- Dark / black tinted glass on door exterior

ACCESSORIES

- 1 x oven rack and 1 x grill/baking tray & grill insert

TECHNICAL INFORMATION

- 3.5kW/hr total electrical consumption
- 15 amp electrical connection, plug & lead supplied
- Size: 594W x 594H x 535D + 21mm fascia

Standard Option - Oven Colour



Black Glass Stainless Steel Grey Glass White Glass



ILVE COMMERCIAL

MULTI-RESIDENTIAL & HOME BUILDER PRODUCT RANGE



ILO60DCX 60CM ELECTRIC BUILT-IN OVEN

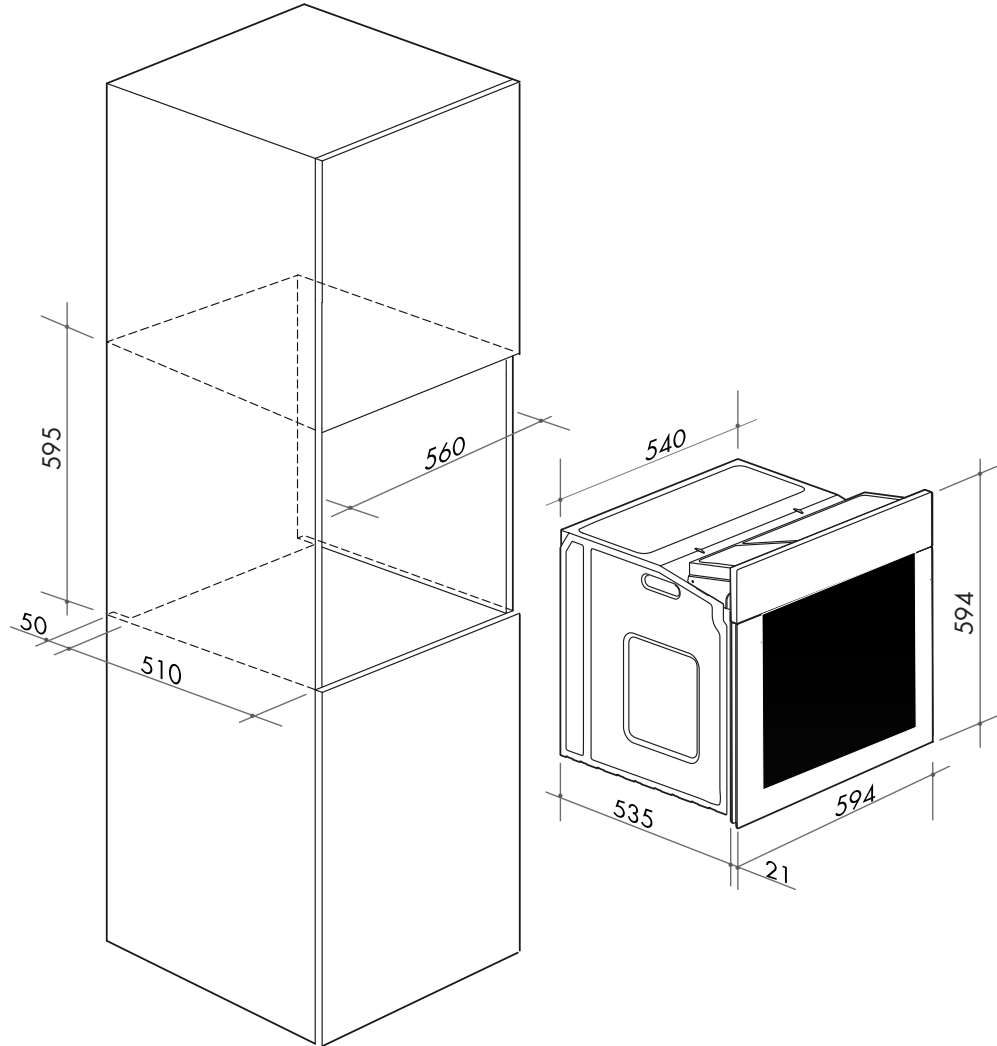

Oven

EAN code: 9341584037565 (ILO60DCX)

Product Size: 594W x 594H x 535D + 21mm fascia

Total Electrical Load: 3.5kW/hr total electrical consumption

NB: drawings are not to scale — they are to be used as a guide only

FOLLOW US:



/ilve_appliances/



/ILVEappliances



/ILVE_appliances



/ILVEappliances

Page 2/2
08052020

Australia National Telephone Number 1300 MYILVE (694 583) New Zealand Telephone Number 0508 458 369
ILVE showrooms are open daily from 9am-5pm and Saturdays 10am-4pm

ilve.com.au

NSW & ACT (Head Office)

48-50 Moore Street
Leichhardt
F 02 8569 4699

VIC & SA

1211 Toorak Road
Camberwell
F 03 9809 2155

QLD

1/42 Cavendish Road
Coorparoo
F 07 3397 0850

WA & NT

Unit 10/55 Howe Street
Osborne Park
F 08 9201 9188

New Zealand

PO Box 11.160
Sockburn Christchurch
F 03 344 5906

DISCLAIMER
Eurolinx PTY LTD, trading as ILVE Appliances, is continually seeking ways to improve the design specifications, aesthetics and production techniques of its products. As a result alterations to our products and designs take place continually. Whilst every effort is made to produce information and literature that is up to date, this brochure should not be regarded as an infallible guide to the current specifications, nor does it constitute an offer for the sale of any particular product. Product dimensions indicated in our literature is indicative only. Actual product only should be used to define dimension cutouts. Distributors, and retailers are not agents of ILVE Appliances and are not authorized to bind ILVE Appliances by any express or implied undertaking or representation.